



QZ系列潜水轴流泵、QH系列潜水混流泵

QZ SERIES AXIAL-FLOW PUMP、QH SERIES MIXED-FLOW PUMP



上海连成（集团）有限公司
SHANGHAI LIANCHENG (GROUP)CO.,LTD.

地址：上海市江桥镇曹安公路3616-3618号
邮编：201812
总机：(021) 59138888
传真：(021) 59136782
800免费咨询电话：800-820-5009
400免费咨询电话：400-188-3339

Address:3616-3618 Can'an Road, Jiangqiao Shanghai
P.C.: 201812
Switchboard: (021) 5913888
Fax: (021) 59136782
800 Free consultation Tel: 800-820-5009
400 Free consultation Tel: 400-188-3339



连成集团微信订阅号

产品简介 Introduction

QZ系列潜水轴流泵、QH系列潜水混流泵是本公司在引进国内外先进技术，根据用户的要求及使用条件精心设计而研制成功的新一代产品。水力模型均达到国内领先水平，和旧模型相比流量提高20%—30%，效率提高3%—5%，且抗汽蚀性能优良。

QZ、QH系列泵具有单机流量大，扬程幅度宽，效率高特点。潜水电机与水泵一体式结构，潜入水中运行，具有传统机组无法比拟的优点：

A: 大大简化泵站土建及建筑结构工程，节约泵站工程造价占总造价30%—40%。

B: 维护简便，有泄漏及内部绕组温升保护装置，可配备控制柜，运行可靠。

C: 噪声低、寿命长。

QZ、QH系列产品的叶轮与叶轮座材料有铸铁、球铁、铸铜（青铜）及不锈钢等，供用户按照所需选取。

产品主要用途 Chief usage

QZ系列潜水轴流泵、QH系列潜水混流泵广泛应用于工农业输送水、城市给水、轻度污水排放及调水工程。

泵的使用条件 Working conditions

不超过50°C的清水及类似清水的其它液体。

QZ series axial-flow pumps、QH series mixed-flow pumps are modern productions successfully designed by the means of adopting foreign modern technology. The new pumps' capacity are 20% larger than the old ones. The efficiency is 3~5% higher than the old ones.

QZ、QH series pump with adjustable impellers has the advantages of large capacity, broad head, high efficiency, wide application and so on.

A: pump station is small in scale, the construction is simple and the investment is greatly decreased, This can save 30%~40% for the building cost.

B: It is easy to install、maintain and repair this kind of pump.

C: low noise、long life.

The material of the series of QZ、QH can be cast iron、ductile iron、copper or stainless steel.

QZ series axial-flow pump、QH series mixed-flow pumps application range: water supply in cities, diversion works, sewage drainage system, sewage disposal project.

The medium for pure-water should be no larger than 50°C.

QZ型潜水轴流泵结构图 QZ type submersible axial-flow pumps structure drawing

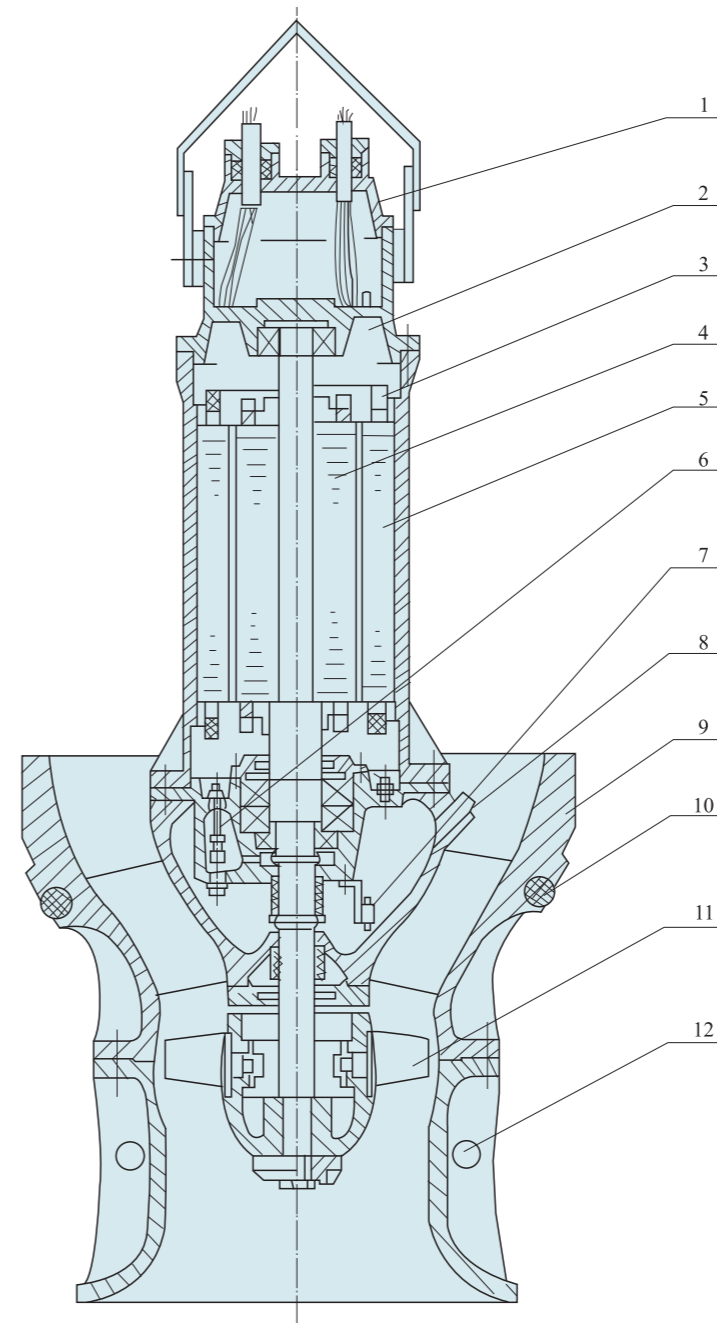

1	接线盒 Junction
2	漏水探头 Leakage probe
3	热保护器 Heat protector
4	转子 Rotor
5	定子 Stator
6	渗漏报警器 Leakage alarm
7	油水探头 Oil-water probe
8	注油孔 Oil filler
9	导叶体 Guide vane
10	密封圈 Seal ring
11	叶轮部件 Impeller part
12	进水喇叭 Suction bell

QH型潜水混流泵结构图 QH type submersible mixed-flow pumps structure drawing

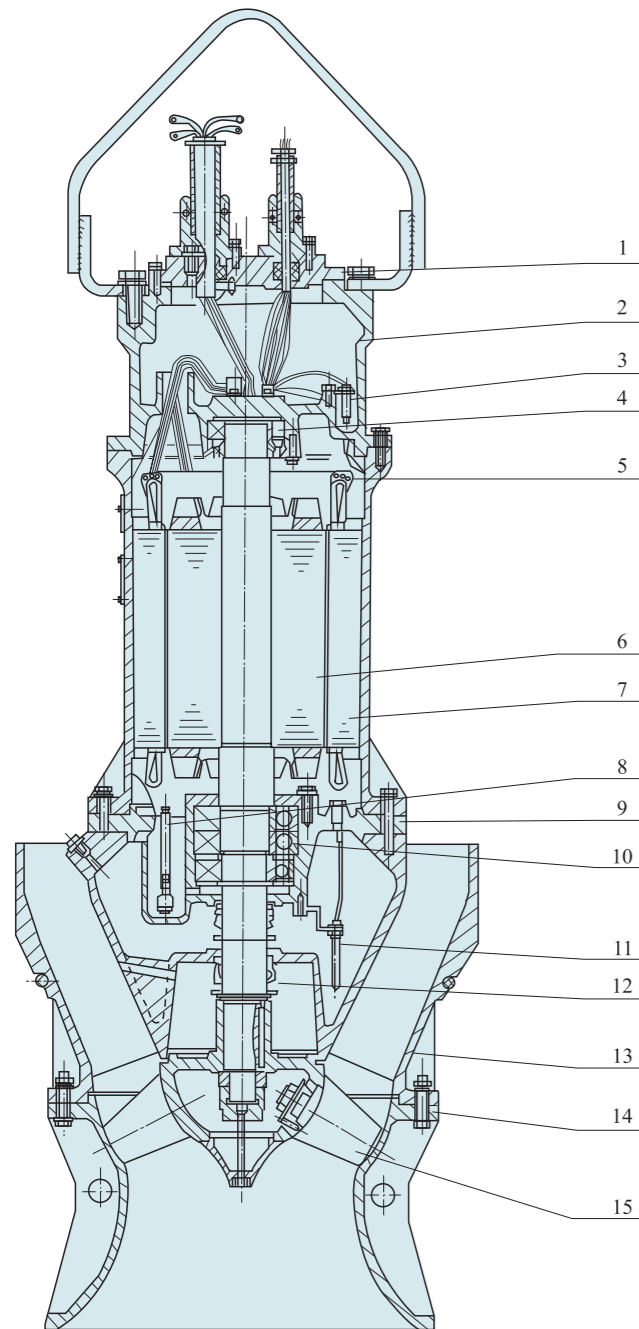

1	接线盒 Junction
2	上端盖 Upper cover
3	漏水检测探头 Leakage probe
4	上轴承 Upper bearing
5	热保护器 Heat protector
6	转子 Rotor
7	定子 Stator
8	渗漏报警器 Leakage alarm
9	下端盖 Bottom cover
10	下轴承 Lower bearing
11	油水检测探头 Oil-water probe
12	机械密封 Mechanical seal
13	导叶体 Guide vane
14	进水喇叭 Suction bell
15	叶轮部件 Impeller part

1600-2400行星齿轮减速潜水电泵结构图
The structure diagram of the 1600-2400 planetary gear deceleration submersible pump

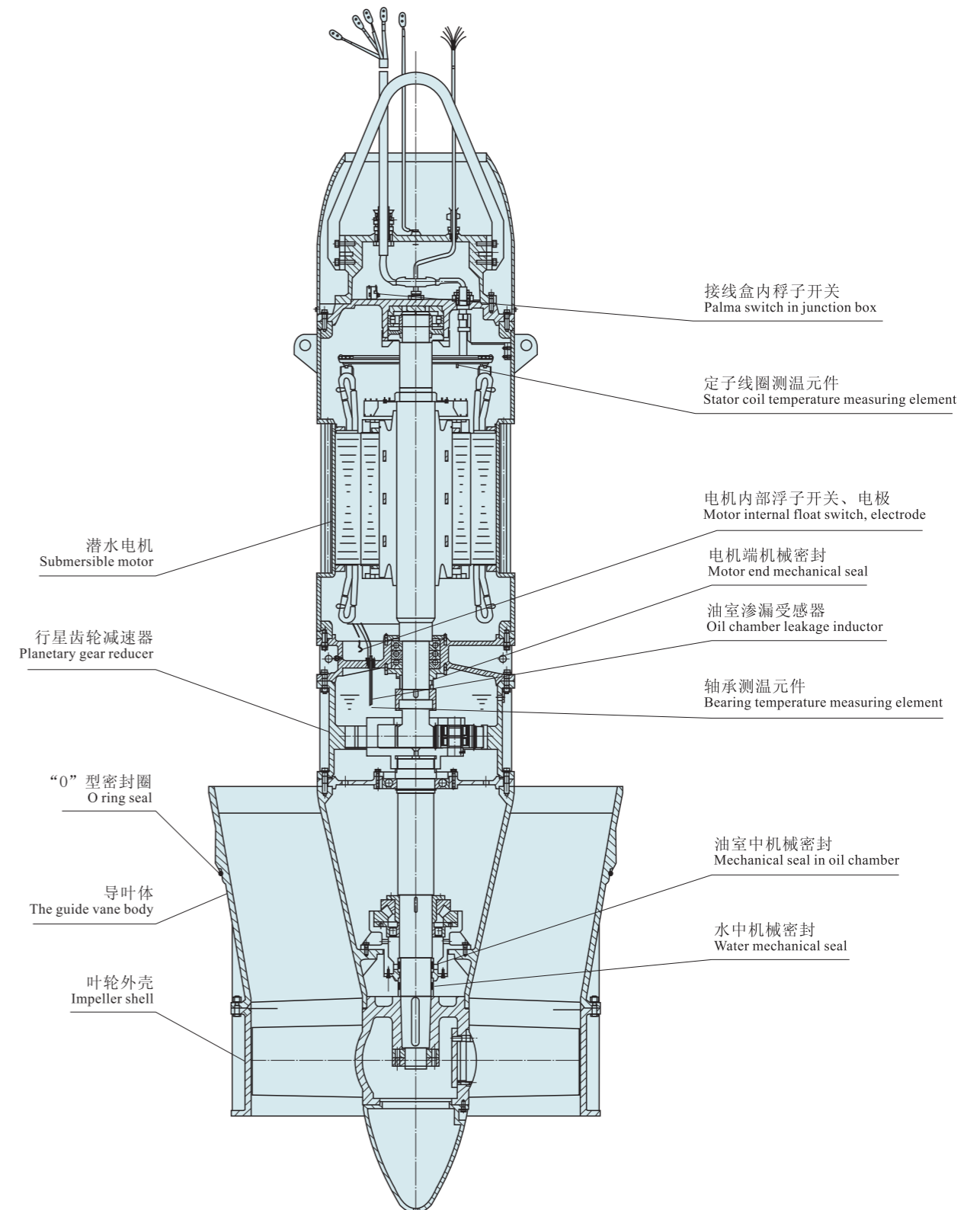

结构说明 Structure

进出水道安装方式

- 1、进水流道：按样本外形安装图推荐形式，泵在液体中最小淹没深度应大于图中值。
- 2、出水方式：拍门或其它方式。
- 3、安装方式：变管悬吊、井筒上出水悬吊、井筒下水悬吊、井筒落地式上出水悬吊、井筒落地式下水悬吊、混凝土预制井筒式。

电机

潜水电机

- 功率等级：电气性能指标符合GB755
- 防护等级：IP68
- 冷却方式：ICW08A41
- 基本安装形式：IM3013
- 电压等级：≤355kw、电压为380V或660V>355kw、电压为380V、660V、6kv、10kv
- 绝缘等级：F
- 额定频率：50Hz
- 电缆长度：10m

轴封

设有两道或三道机械密封。第一道与水直接接触的机械密封一般为碳化硅对碳化钨，第二、第三道一般为石墨对碳化钨。

防漏保护

QZ、QH系列泵设有防漏保护传感器。当油室、电机腔或接线盒内被水渗漏时，传感器发出警报或停机，并保留故障信号。

过热保护装置

潜水电机绕组中设有过热保护器，当温度超过规定时，发出信号或停机。

转向

从电机上方看，叶轮顺时针方向旋转。

Installation of Suction and Discharge Pipes

- 1.Suction Pipe:according to the outline drawing in the booklet. The smallest depth of the pump under the water should be bigger than the datum in the drawing.
- 2.Discharge:flap valve and other methods.
- 3.Installation:Variable tube suspension, water suspension on the shaft, shaft under water suspension, wellbore water suspension on the floor, wellbore water suspension, prefabricated concrete shaft type under the floor.

Motor

1. Submersible Motor(QZ series)
 - Power class:electric performance meets GB755
 - Protection class:IP68
 - Cooling system:ICW08A41
 - Basic installation type: IM3013
 - Voltage: up to 355kw, 380V、600V、355KW, 380V、600V、6kv, 10kv
 - Insulation class: F
 - Rated power: 50Hz
 - Length of cable: 10m

Shaft Seal

This type has two or three mechanical seals. The first seal, which contacts water, is usually made of carbon silicon and tungsten carbide. The second and third are usually made of graphite and tungsten carbide.

Leakage Protection

QZ、QH series has leakage protection sensor. When the oil house of motor or the wire-box is leaking, sensor will give out warning or stop working and maintain the signal.

Overheat Protector

The winding of QZ series submersible motor has overheat protector. When it is overheated, warning will be given out or the motor will stop working.

Rotating Direction

Looking from upper side, the impeller is rotating clockwise.
Series Definition

型号意义 Model meaning

1.产品代号

- QZ-叶片可调式潜水轴流泵
- QH-叶片可调式潜水混流泵

1.Series Code

- QZ-impeller adjustable submersible axial flow pump
- QH-impeller adjustable submersible mixed flow pump

2. Example

2.型号举例

350 QZ(H) - 70 - C D

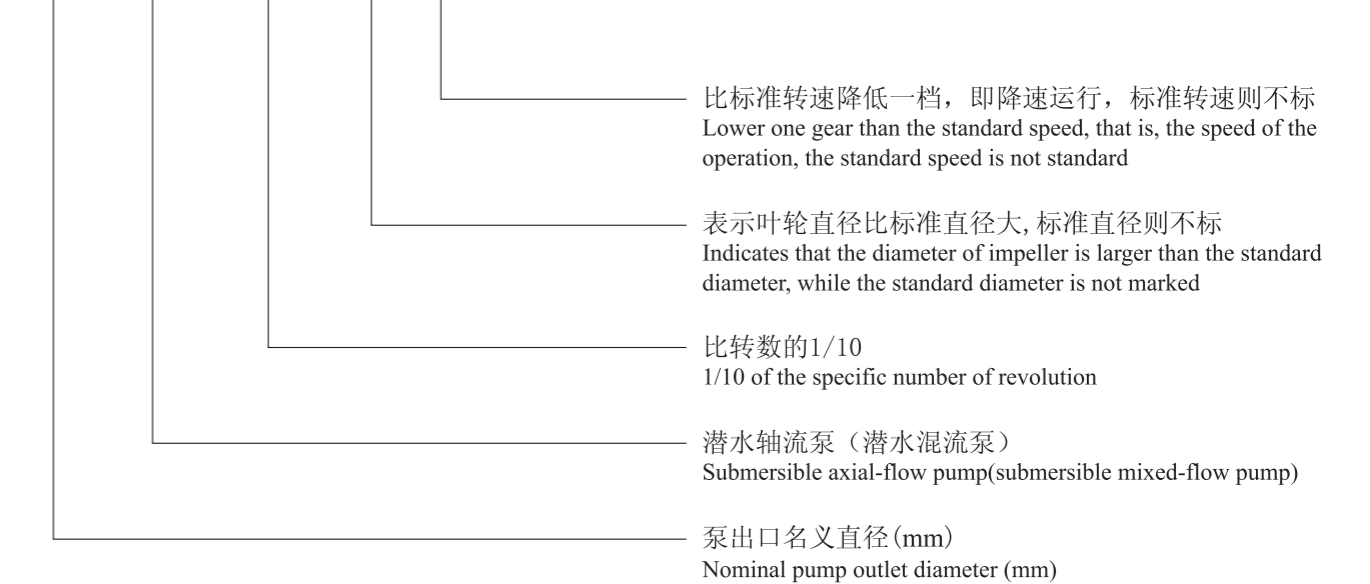

1800 QZX - 85 - C D

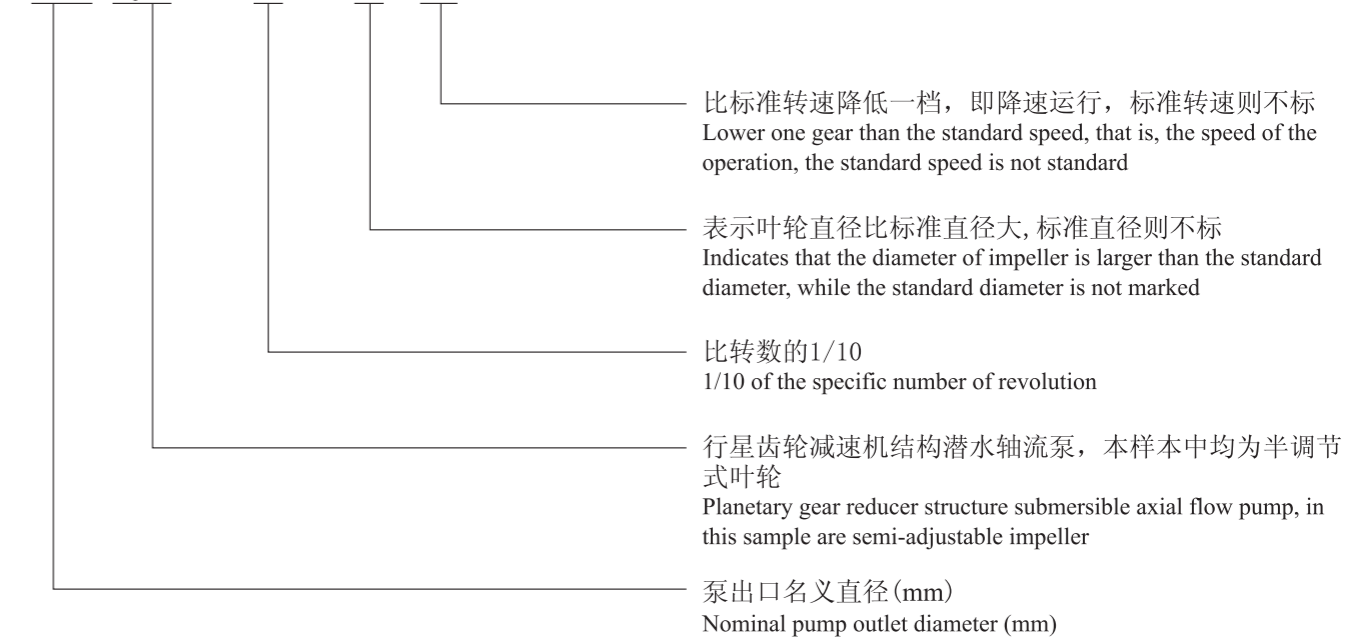

型谱图 Spectrum diagram

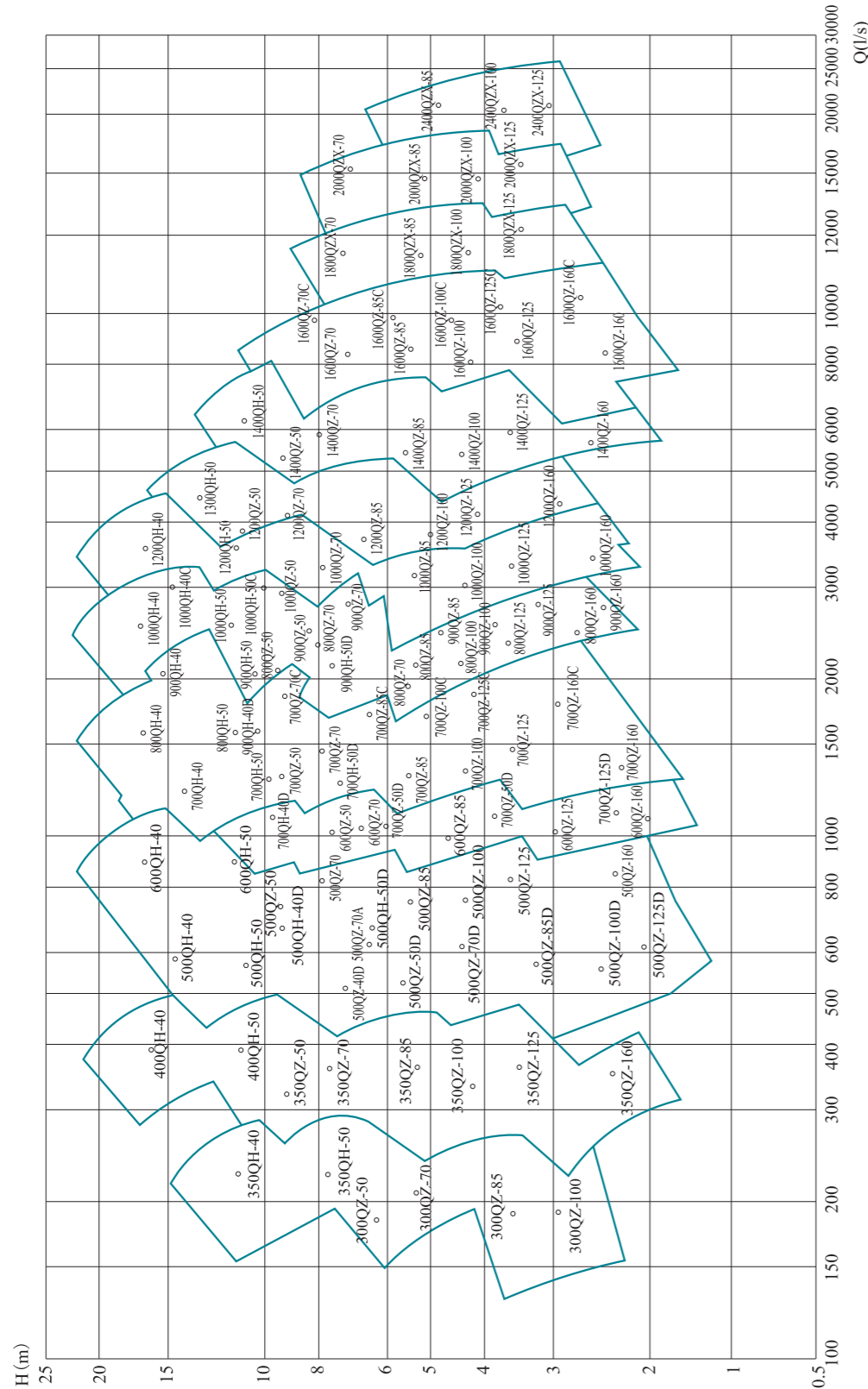

QZ、QH型潜水轴流泵、混流泵性能曲线图与性能参数表 Curve and specification

300QZ-85

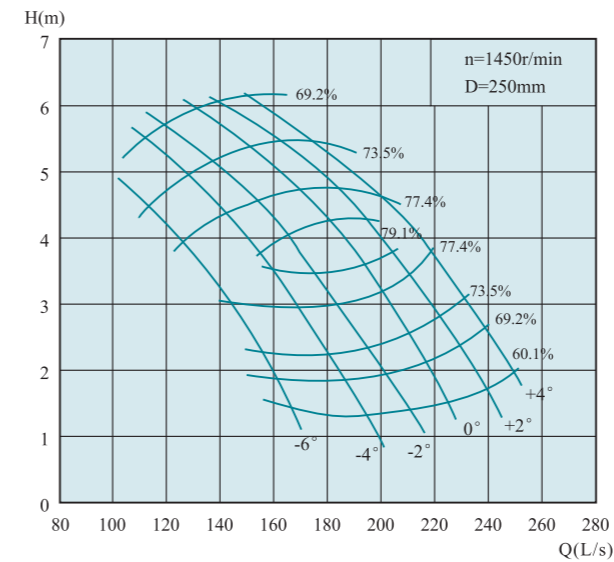

叶片安装角度 Angle	流量Q Capacity		扬程H Head (m)	转速n Speed (r/min)	功率P Power(kw)		效率η Eff. (%)	叶轮直径 Diameter of impeller (mm)	
	(m³/h)	(L/s)			轴功率 Shaft power	电机功率 Motor power			
-6°	564.5	156.8	1.94	1450	4.3	7.5	69.3	250	
	516.6	143.5	2.94		5.3		78.3		
	364.7	101.3	4.97		7.1		69.3		
-4°	654.1	181.7	1.88		11	4.8	69.3		69.3
	558.4	155.1	3.61			6.9	79.3		
	400	111.1	5.27			8.3	69.3		
-2°	735.5	204.3	1.94		15	5.6	69.3		69.3
	635.4	176.5	3.54			7.7	79.3		
	439.6	122.1	5.52			9.5	69.3		
0°	791.6	219.9	2.12		15	6.6	69.3		69.3
	695.9	193.3	3.67			8.7	80.3		
	483.5	134.3	5.73			10.9	69.3		
+2°	846	235	2.43	15	8.1	69.3	69.3		
	743.8	206.6	3.92		10	79.3			
	527	146.4	5.9		12.2	69.3			
+4°	900	250	2.73	15	9.7	69.3	69.3		
	760.3	211.2	4.44		11.7	78.3			
	574.9	159.7	5.89		13.3	69.3			

300QZ-100

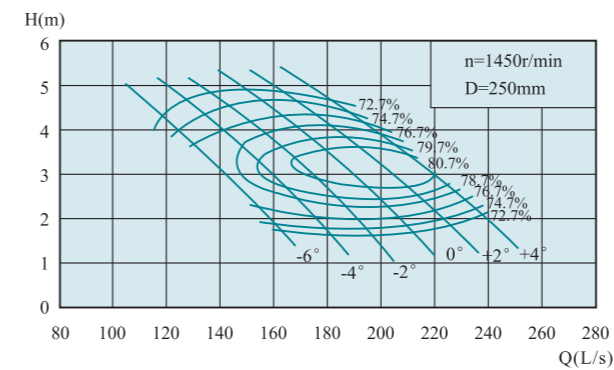

叶片安装角度 Angle	流量Q Capacity		扬程H Head (m)	转速n Speed (r/min)	功率P Power(kw)		效率η Eff. (%)	叶轮直径 Diameter of impeller (mm)	
	(m³/h)	(L/s)			轴功率 Shaft power	电机功率 Motor power			
-6°	554	153.9	2.22	1450	4.4	7.5	76.7	250	
	520.9	144.7	2.8		5.1		78.3		
	468.7	130.2	3.68		6.1		76.7		
-4°	633.2	175.9	2.03		11	4.6	76.7		76.7
	583.2	162	2.85			5.7	79.8		
	509.4	141.5	3.99			7.2	76.7		
-2°	689.8	191.6	1.98		15	4.9	76.7		76.7
	635.4	176.5	2.92			6.3	80.4		
	545.8	151.6	4.19			8.1	76.7		
0°	743.8	206.6	2.04		15	5.4	76.7		76.7
	687.6	191	2.92			6.8	80.7		
	586.4	162.9	4.34			9	76.7		
+2°	791.6	219.9	2.2	15	6.2	76.7	76.7		
	729	202.5	3.08		7.5	81.2			
	633.2	175.9	4.35		9.8	76.7			
+4°	833.4	231.5	2.42	15	7.2	76.7	76.7		
	781.2	217	3.09		8.1	80.9			
	698	193.9	4.17		10.3	76.7			

QZ、QH型潜水轴流泵、混流泵性能曲线图与性能参数表 Curve and specification

300QZ-50

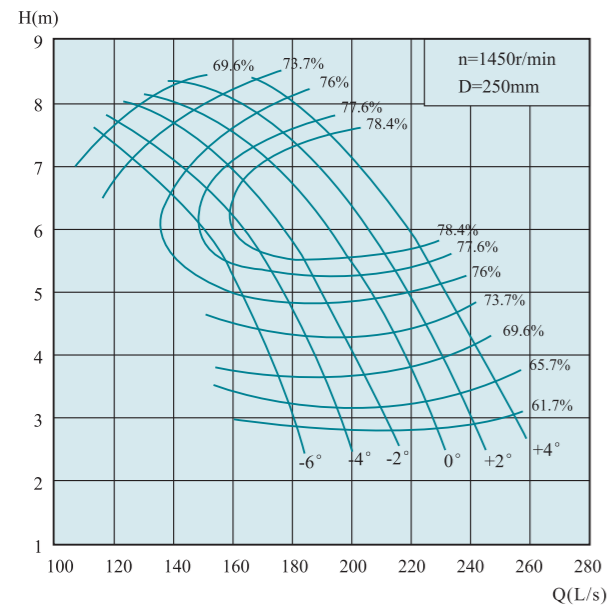

叶片安装角度 Angle	流量Q Capacity		扬程H Head (m)	转速n Speed (r/min)	功率P Power(kw)		效率η Eff. (%)	叶轮直径 Diameter of impeller (mm)	
	(m³/h)	(L/s)			轴功率 Shaft power	电机功率 Motor power			
-6°	636.8	176.9	3.24	1450	8.6	15	65.7	250	
	537.5	149.3	5.92		11.1		77.9		
	425.5	118.2	7.46		12.3		70.6		
-4°	691.6	192.1	3.18		9.1		18.5		65.7
	584.3	162.3	6.11		12.3				79.1
	439.2	122	7.81		13.2				70.6
-2°	746.6	207.4	3.18		9.8	22			65.7
	601.9	167.2	6.29		13				79.1
	460.8	128	8.03		14.3				70.6
0°	806.4	224	3.33		11.1		30		65.7
	668.5	185.7	6.32		14.5				79.3
	533.9	148.3	7.92		15.6				73.7
+2°	855	237.5	3.41	12.1	45	65.7			
	703.8	195.5	6.48	15.7		79.1			
	574.6	159.6	8.18	17.4		73.7			
+4°	887.8	246.6	3.7	13.6		60	65.7		
	740.2	205.6	6.66	17			79.1		
	601.6	167.1	8.33	18.5			73.7		

QZ、QH型潜水轴流泵、混流泵性能曲线图与性能参数表 Curve and specification

350QH-40

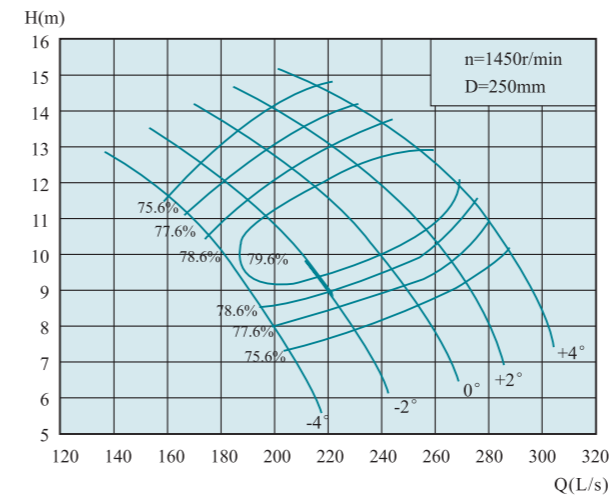

叶片安装角度 Angle	流量Q Capacity		扬程H Head (m)	转速n Speed (r/min)	功率P Power(kw)		效率η Eff. (%)	叶轮直径 Diameter of impeller (mm)	
	(m³/h)	(L/s)			轴功率 Shaft power	电机功率 Motor power			
-4°	739.4	205.4	7.38	1450	19.7	30	75.6	250	
	677.2	188.1	9.48		22		79.4		
	581.4	161.5	11.74		24.6		75.6		
-2°	829.1	230.3	7.96		23.8		45		75.6
	749.9	208.3	10.28		26.4				79.6
	625	173.6	12.66		28.5				75.6
0°	910.4	252.9	8.59		28.2	60			75.6
	812.5	225.7	11.18		31				79.9
	672.8	186.9	13.59		33				75.6
+2°	977	271.4	9.29		32.7		75		75.6
	875.2	243.1	11.81		34.9				80.6
	718.9	199.7	14.27		37				75.6
+4°	1035.4	287.6	10.24	38.2	90	75.6			
	937.4	260.4	12.64	40.3		80.1			
	781.2	217	14.85	41.8		75.6			

300QZ-70

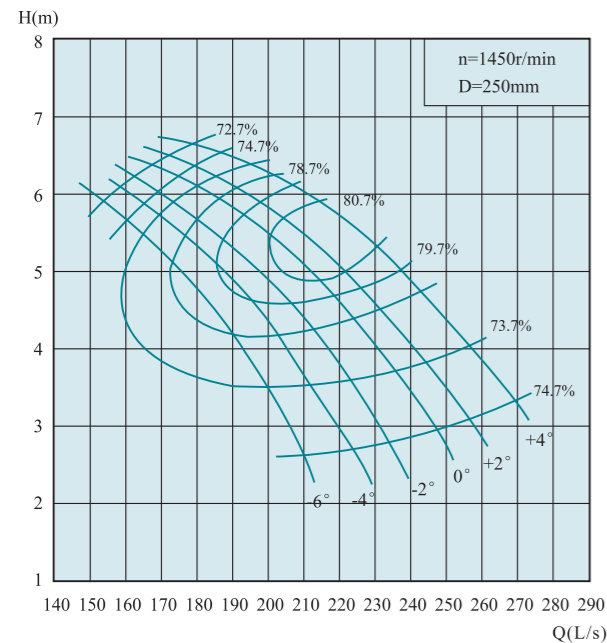

叶片安装角度 Angle	流量Q Capacity		扬程H Head (m)	转速n Speed (r/min)	功率P Power(kw)		效率η Eff. (%)	叶轮直径 Diameter of impeller (mm)	
	(m³/h)	(L/s)			轴功率 Shaft power	电机功率 Motor power			
-6°	749.9	208.3	2.6	1450	6.9	15	76.9	250	
	666.7	185.2	4.58		10.3		80.9		
	552.2	153.4	5.9		11.9		74.9		
-4°	802.1	222.8	2.67		7.6		18.5		76.9
	683.3	189.8	4.86		11				82.1
	572.8	159.1	6.17		12.9				74.9
-2°	843.8	234.4	2.78		8.3	30			76.9
	718.9	199.7	5.07		12.1				82.3
	585.4	162.6	6.25		13.3				74.9
0°	885.2	245.9	2.99		9.4		45		76.9
	748.1	207.8	5.29		12.9				83.4
	600.1	166.7	6.46		14.1				74.9
+2°	916.6	254.6	3.13	10.2	60	76.9			
	766.8	213	5.35	13.3		83.8			
	606.2	168.4	6.53	14.4		74.9			
+4°	962.6	267.4	3.4	11.6		75	76.9		
	796	221.1	5.69	14.9			82.9		
	643.7	178.8	6.67	15.6			74.9		

350QH-50

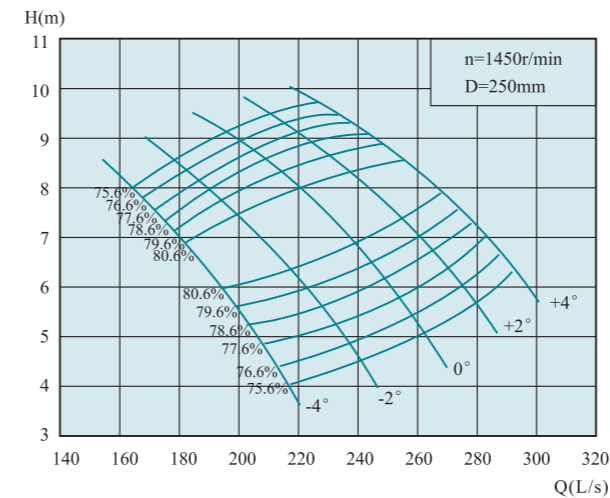

叶片安装角度 Angle	流量Q Capacity		扬程H Head (m)	转速n Speed (r/min)	功率P Power(kw)		效率η Eff. (%)	叶轮直径 Diameter of impeller (mm)	
	(m³/h)	(L/s)			轴功率 Shaft power	电机功率 Motor power			
-4°	768.6	213.5	4.41	1450	12.1	18.5	76.6	250	
	666.7	185.2	6.74		15.2		80.6		
	601.9	167.2	7.81		16.7		76.6		
-2°	854.3	237.3	4.86		14.8		30		76.6
	729	202.5	7.29		17.9				80.7
	654.1	181.7	8.33		19.4				76.6
0°	931.3	258.7	5.42		18	45			76.6
	812.5	225.7	7.64		21				80.6
	720.7	200.2	8.92		22.9				76.6
+2°	989.6	274.9	6.04		21.3		60		76.6
	854.3	237.3	8.33		24.1				80.6
	783.4	217.6	9.31		25.9				76.6
+4°	1037.5	288.2	6.6	24.4	75	76.6			
	916.6	254.6	8.61	26.7		80.6			
	837.4	232.6	9.51	28.3		76.6			

外形安装尺寸图 Outline installation dimension drawing

300QZ-50, 300QZ-70, 300QZ-85, 300QZ-100,
350QH-40, 350QH-50

1、井筒悬吊式安装
Suspension installation of wellbore

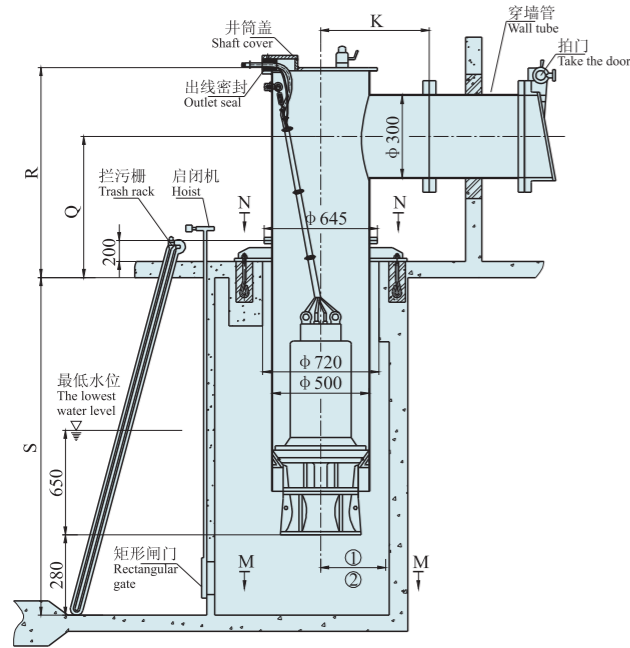

2、混凝土预制井筒式安装
Precast concrete shaft installation

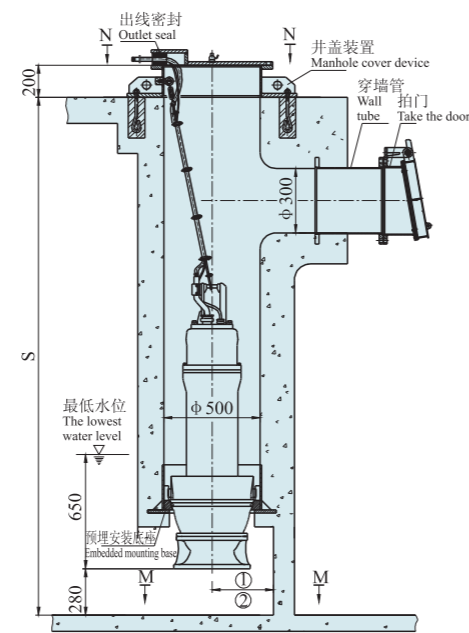

3、弯管悬吊式安装
Bend suspension installation

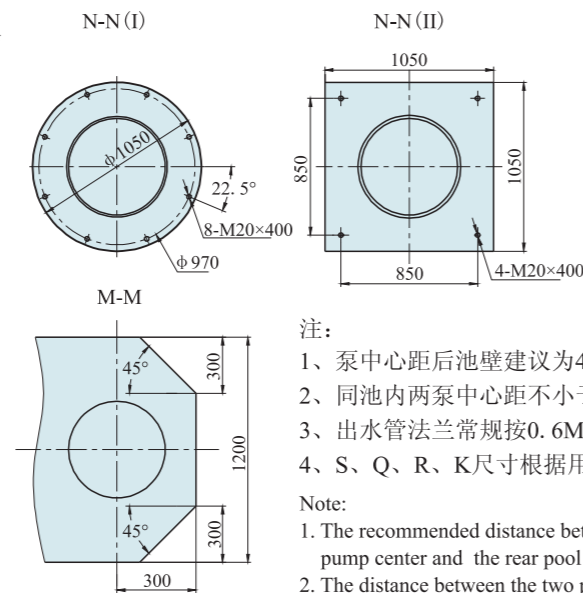
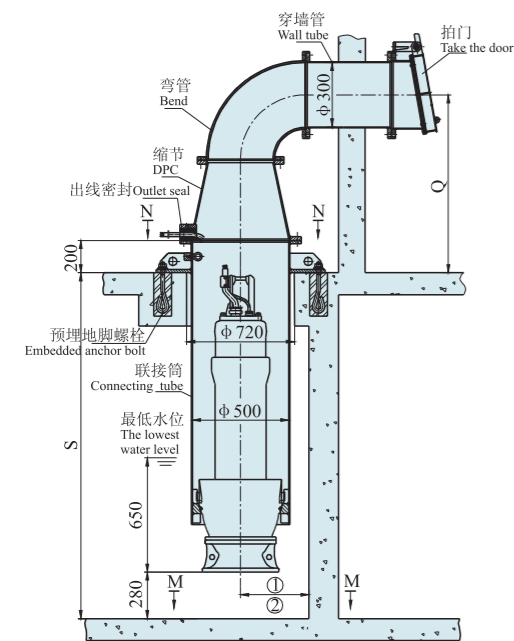

- 注:
- 1、泵中心距后池壁建议为400;
 - 2、同池内两泵中心距不小于1400;
 - 3、出水管法兰常规按0.6MPa;
 - 4、S、Q、R、K尺寸根据用户要求。

- Note:
1. The recommended distance between the pump center and the rear pool wall is 400;
 2. The distance between the two pump centers in the same pool shall not be less than 1400;
 3. The outlet pipe flange is normally 0.6mpa;
 4. Sizes of S, Q, R and K are according to user requirements.

QZ、QH型潜水轴流泵、混流泵性能曲线图与性能参数表 Curve and specification

350QZ-50

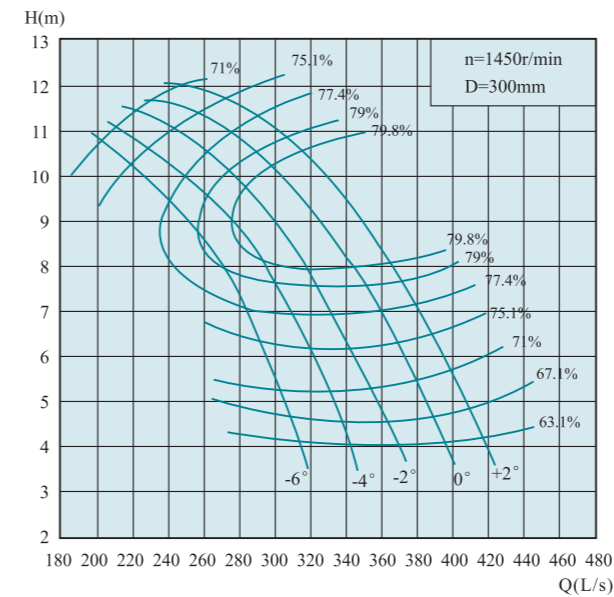

叶片安装角度 Angle	流量Q Capacity		扬程H Head (m)	转速n Speed (r/min)	功率P Power(kw)		效率η Eff. (%)	叶轮直径 Diameter of impeller (mm)
	(m³/h)	(L/s)			轴功率 Shaft power	电机功率 Motor power		
-6°	1100.5	305.7	4.67	1450	20.9	37	67.1	300
	928.8	258	8.53		27.2		79.3	
	735.5	204.3	10.74		29.9		72	
-4°	1195.2	332	4.58		22.2		67.1	
	1009.8	280.5	8.79		30		80.5	
	758.9	210.8	11.25		32.3		72	
-2°	1290.2	358.4	4.58		24	67.1		
	1040.4	289	9.05		31.9	80.5		
	796.3	221.2	11.56		34.8	72		
0°	1393.2	387	4.8		27.2	67.1		
	1155.6	321	9.1		35.5	80.7		
	922.7	256.3	11.4		38.2	75.1		
+2°	1477.8	410.5	4.91	29.5	67.1			
	1216.4	337.9	9.33	38.4	80.5			
	992.9	275.8	11.78	42.4	75.1			

350QZ-70

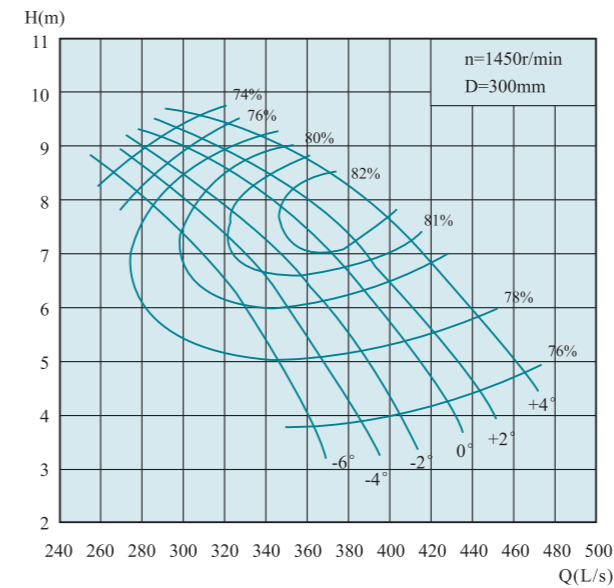

叶片安装角度 Angle	流量Q Capacity		扬程H Head (m)	转速n Speed (r/min)	功率P Power(kw)		效率η Eff. (%)	叶轮直径 Diameter of impeller (mm)
	(m³/h)	(L/s)			轴功率 Shaft power	电机功率 Motor power		
-6°	1296	360	3.75	1450	17.4	37	69.3	300
	1152	320	6.6		25.9		78.3	
	954	265	8.5		29.9		69.3	
-4°	1386	385	3.85		19.1		69.3	
	1180.8	328	7		27.7		79.3	
	990	275	8.88		32.4		69.3	
-2°	1458	405	4		20.9	69.3		
	1242	345	7.3		30.4	79.3		
	1011.6	281	9		33.5	69.3		
0°	1530	425	4.3		23.6	69.3		
	1292.4	359	7.62		32.5	80.3		
	1036.8	288	9.3		35.5	69.3		
+2°	1584	440	4.5	25.6	69.3			
	1324.8	368	7.7	33.5	79.3			
	1047.6	291	9.4	36.3	69.3			
+4°	1663.2	462	4.9	29.2	69.3			
	1375.2	382	8.2	37.5	78.3			
	1112.4	309	9.6	39.3	69.3			

QZ、QH型潜水轴流泵、混流泵性能曲线图与性能参数表 Curve and specification

350QZ-85

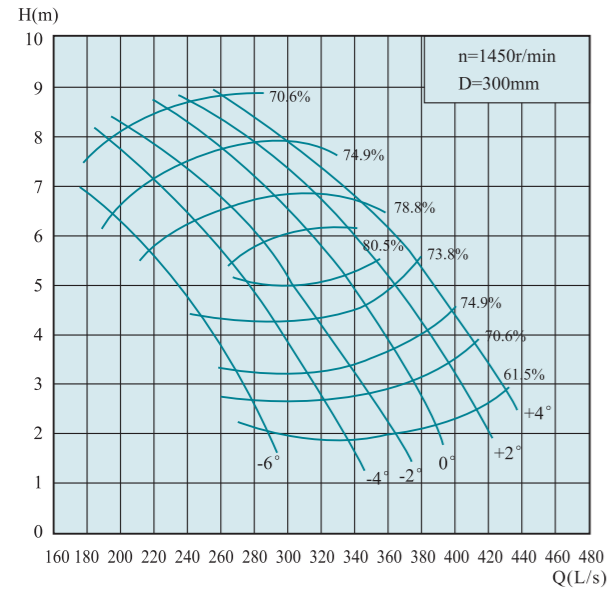

叶片安装角度 Angle	流量Q Capacity		扬程H Head (m)	转速n Speed (r/min)	功率P Power(kw)		效率η Eff. (%)	叶轮直径 Diameter of impeller (mm)
	(m³/h)	(L/s)			轴功率 Shaft power	电机功率 Motor power		
-6°	975.6	271	2.79	1450	10.5	18.5	70.7	300
	892.8	248	4.24		12.9		79.7	
	630	175	7.15		17.4		70.7	
-4°	1130.4	314	2.7		11.8	22	70.7	
	964.8	268	5.2		16.9		80.7	
	691.2	192	7.59		20.2		70.7	
-2°	1270.8	353	2.79		13.7	30	70.7	
	1098	305	5.1		18.9		80.7	
	759.6	211	7.95		23.3		70.7	
0°	1368	380	3.05		16.1	30	70.7	
	1202.4	334	5.29		21.2		81.7	
	835.2	232	8.25		26.6		70.7	
+2°	1461.6	406	3.5	19.7	37	70.7		
	1285.2	357	5.65	24.5		80.7		
	910.8	253	8.49	29.8		70.7		
+4°	1555.2	432	3.93	23.6	37	70.7		
	1314	365	6.39	28.7		79.7		
	993.6	276	8.48	32.5		70.7		

QZ、QH型潜水轴流泵、混流泵性能曲线图与性能参数表 Curve and specification

350QZ-125

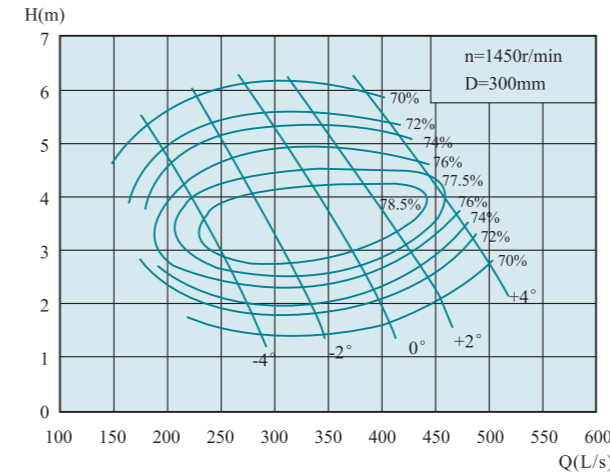

叶片安装角度 Angle	流量Q Capacity		扬程H Head (m)	转速n Speed (r/min)	功率P Power(kw)		效率η Eff. (%)	叶轮直径 Diameter of impeller (mm)
	(m³/h)	(L/s)			轴功率 Shaft power	电机功率 Motor power		
-4°	979.2	272	2.04	1450	7.4	15	74	300
	892.8	248	3.03		9.4		78.5	
	712.8	198	4.93		13.3		72	
-2°	1198.8	333	2.03		9	22	74	
	1105.2	307	3.14		12		78.9	
	871.2	242	5.34		17.6		72	
0°	1414.8	393	2.28		11.9	30	74	
	1303.2	362	3.46		15.5		79.5	
	1047.6	291	5.6		22.2		72	
+2°	1573.2	437	2.7		15.6	30	74	
	1447.2	402	3.58		17.9		78.9	
	1213.2	337	5.6		25.7		72	
+4°	1717.2	477	3.46	21.9	37	74		
	1645.2	457	3.96	22.8		77.8		
	1468.8	408	5.41	30.1		72		

350QZ-100

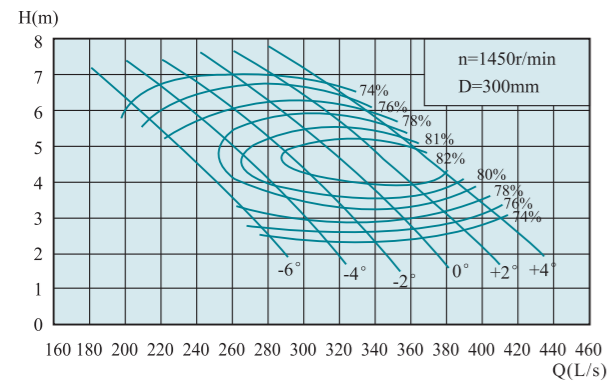

叶片安装角度 Angle	流量Q Capacity		扬程H Head (m)	转速n Speed (r/min)	功率P Power(kw)		效率η Eff. (%)	叶轮直径 Diameter of impeller (mm)
	(m³/h)	(L/s)			轴功率 Shaft power	电机功率 Motor power		
-6°	957.6	266	3.2	1450	10.7	18.5	78	300
	900	250	4.03		12.4		79.6	
	810	225	5.3		15		78	
-4°	1094.4	304	2.93		11.2	22	78	
	1008	280	4.1		13.9		81.1	
	880.2	244.5	5.75		17.7		78	
-2°	1191.6	331	2.85		11.9	30	78	
	1098	305	4.21		15.4		81.7	
	943.2	262	6.03		19.9		78	
0°	1285.2	357	2.94		13.2	30	78	
	1188	330	4.2		16.6		82	
	1013.4	281.5	6.25		22.1		78	
+2°	1368	380	3.17	15.2	30	78		
	1260	350	4.43	18.4		82.5		
	1094.4	304	6.27	24		78		
+4°	1440	400	3.48	17.5	37	78		
	1350	375	4.45	19.9		82.2		
	1206	335	6	25.3		78		

350QZ-160

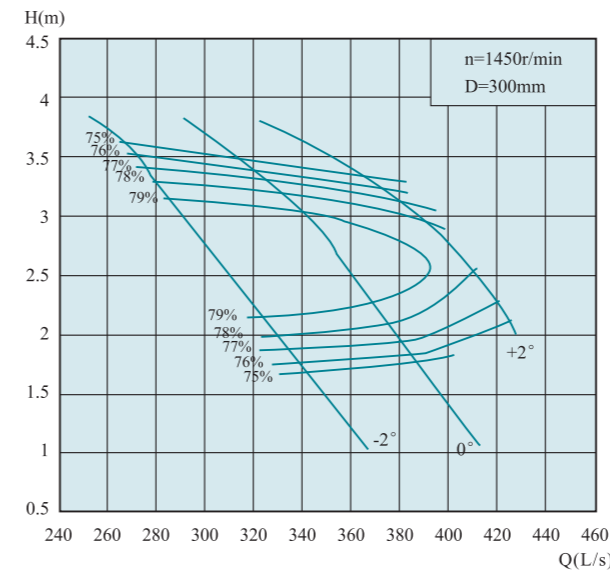

叶片安装角度 Angle	流量Q Capacity		扬程H Head (m)	转速n Speed (r/min)	功率P Power(kw)		效率η Eff. (%)	叶轮直径 Diameter of impeller (mm)
	(m³/h)	(L/s)			轴功率 Shaft power	电机功率 Motor power		
-2°	1219	338.6	1.76	1450	7.7	15	76	300
	1116	310	2.49		9.4		80.5	
	977.4	271.5	3.53		12.4		76	
0°	1377.7	382.7	1.82		9	14	76	
	1296	360	2.5		11.1		79.5	
	1154.5	320.7	3.38		14		76	
+2°	1526.8	424.1	2.1		11.5	18.5	76	
	1447.2	402	2.7		13.7		78	
	1340.6	372.4	3.23		15.5		76	

QZ、QH型潜水轴流泵、混流泵性能曲线图与性能参数表 Curve and specification

400QH-40

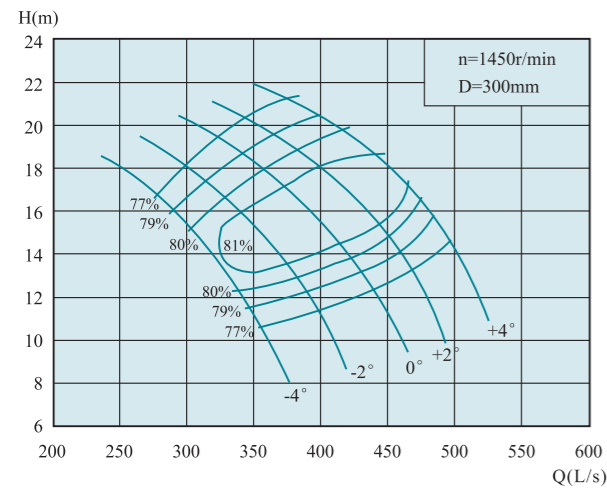

叶片安装角度 Angle	流量Q Capacity		扬程H Head (m)	转速n Speed (r/min)	功率P Power(kw)		效率η Eff. (%)	叶轮直径 Diameter of impeller (mm)	
	(m³/h)	(L/s)			轴功率 Shaft power	电机功率 Motor power			
-4°	1278	355	10.63	1450	48.1	75	77	300	
	1170	325	13.65		53.9		80.8		
	1004.4	279	16.9		60.1		77		
-2°	1432.8	398	11.46		58.1	77	77		
	1296	360	14.8		64.5	81	77		
	1080	300	18.23		69.7	77	77		
0°	1573.2	437	12.37		68.9	90	77		77
	1404	390	16.1		75.8		81.3		77
	1162.8	323	19.57		80.5		77		77
+2°	1688.4	469	13.38		79.9	110	77		77
	1512	420	17		85.4		82		77
	1242	345	20.55		90.3		77		77
+4°	1789.2	497	14.75	93.4		77	77		
	1620	450	18.2	98.6		81.5	77		
	1350	375	21.38	102.1		77	77		

400QH-50

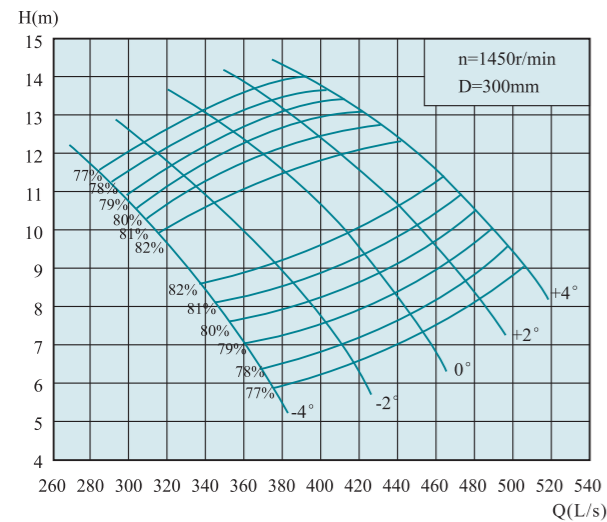

叶片安装角度 Angle	流量Q Capacity		扬程H Head (m)	转速n Speed (r/min)	功率P Power(kw)		效率η Eff. (%)	叶轮直径 Diameter of impeller (mm)	
	(m³/h)	(L/s)			轴功率 Shaft power	电机功率 Motor power			
-4°	1328.4	369	6.35	1450	29.5	45	78	300	
	1152	320	9.7		37.1		82		
	1040.4	289	11.25		40.9		78		
-2°	1476	410	7		36.1	55	78		78
	1260	350	10.5		43.9		82.1		78
	1130.4	314	12		47.4		78		78
0°	1609.2	447	7.8		43.9	75	78		78
	1404	390	11		51.3		82		78
	1245.6	346	12.85		55.9		78		78
+2°	1710	475	8.7		52		78		78
	1476	410	12		58.9		82		78
	1353.6	376	13.4		63.4		78		78
+4°	1792.8	498	9.5	59.5		78	78		
	1584	440	12.4	65.3		82	78		
	1447.2	402	13.7	69.3		78	78		

外形安装尺寸图 Outline installation dimension drawing

350QZ-50, 350QZ-70, 350QZ-85, 350QZ-100, 350QZ-125, 350QZ-160, 400QH-40, 400QH-50

1、井筒悬吊式安装
Suspension installation of wellbore

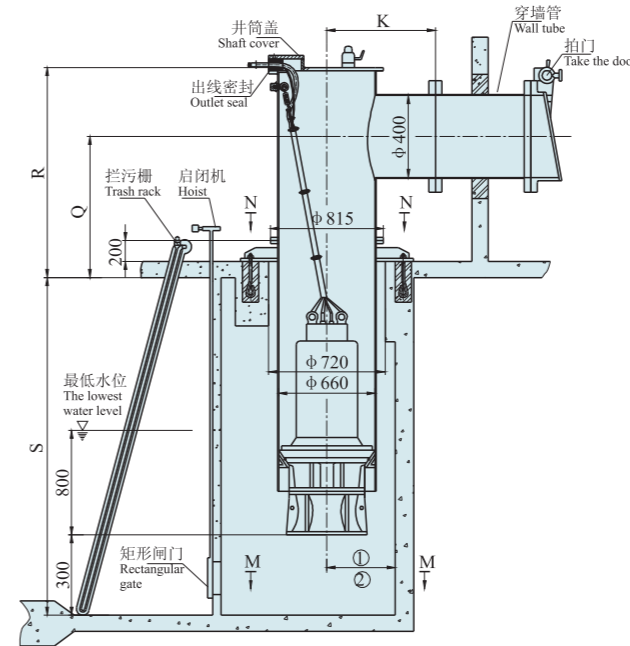

2、混凝土预制井筒式安装
Precast concrete shaft installation

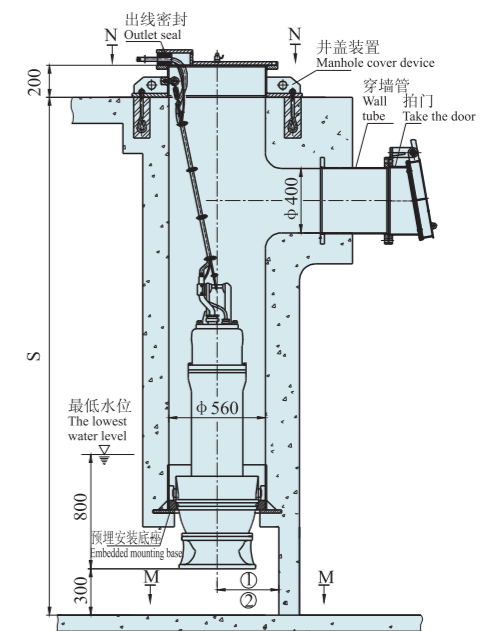

3、弯管悬吊式安装
Bend suspension installation

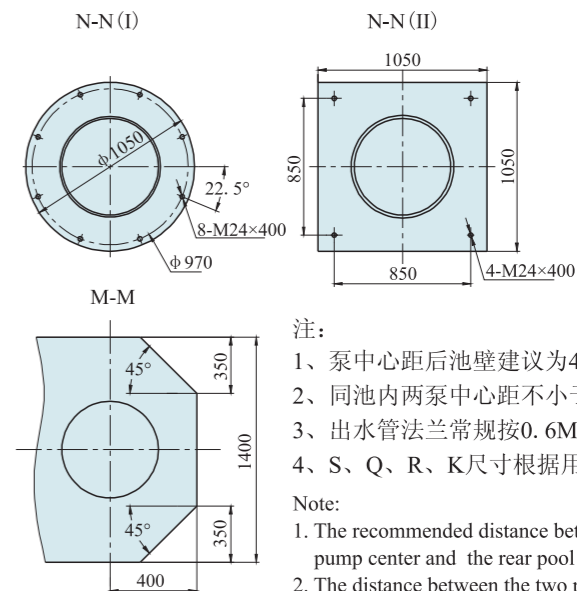
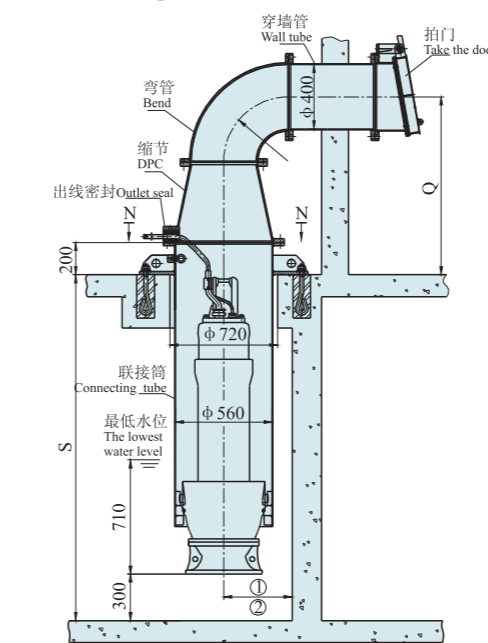

- 注:
- 1、泵中心距后池壁建议为400;
 - 2、同池内两泵中心距不小于1400;
 - 3、出水管法兰常规按0.6MPa;
 - 4、S、Q、R、K尺寸根据用户要求。
- Note:
1. The recommended distance between the pump center and the rear pool wall is 400;
 2. The distance between the two pump centers in the same pool shall not be less than 1400;
 3. The outlet pipe flange is normally 0.6mpa;
 4. Sizes of S, Q, R and K are according to user requirements.

QZ、QH型潜水轴流泵、混流泵性能曲线图与性能参数表 Curve and specification

500QH-40

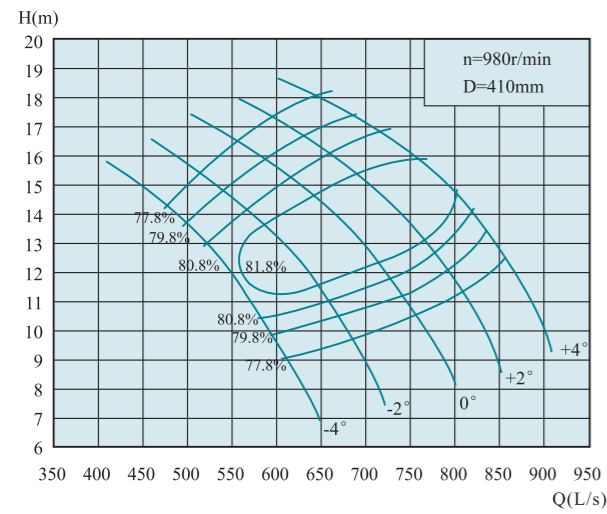

叶片安装角度 Angle	流量Q Capacity		扬程H Head (m)	转速n Speed (r/min)	功率P Power(kw)		效率η Eff. (%)	叶轮直径 Diameter of impeller (mm)	
	(m³/h)	(L/s)			轴功率 Shaft power	电机功率 Motor power			
-4°	2205	612.5	9.07	980	70	90	77.8	410	
	2018.5	560.7	11.65		78.5	90	81.6		
	1732.7	481.3	14.42		87.5	90	77.8		
-2°	2471.8	686.6	9.78		84.7	110	77.8		160
	2236	621.1	12.63		94.1	110	81.8		
	1863.4	517.6	15.55		101.5	110	77.8		
0°	2714	753.9	10.55		100.3	132	77.8		160
	2422.1	672.8	13.74		110.5	132	82.1		
	2005.9	557.2	16.7		117.3	132	77.8		
+2°	2912.8	809.1	11.42		116.5	160	77.8		160
	2608.6	724.6	14.5		124.5	160	82.8		
	2142.7	595.2	17.53		131.6	160	77.8		
+4°	3086.6	857.4	12.58	136	160	77.8	160		
	2795	776.4	15.53	143.7	160	82.3			
	2329.2	647	18.24	148.8	160	77.8			

500QH-40D

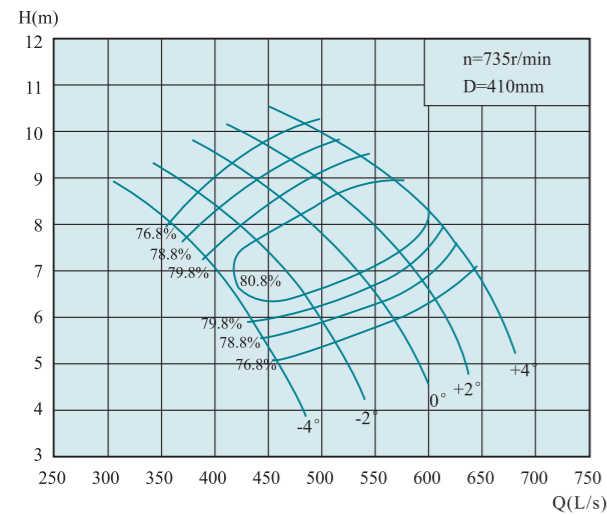

叶片安装角度 Angle	流量Q Capacity		扬程H Head (m)	转速n Speed (r/min)	功率P Power(kw)		效率η Eff. (%)	叶轮直径 Diameter of impeller (mm)	
	(m³/h)	(L/s)			轴功率 Shaft power	电机功率 Motor power			
-4°	1653.5	459.3	5.1	735	29.9	45	76.8	410	
	1513.8	420.5	6.55		33.5	45	80.6		
	1299.6	361	8.11		37.4	45	76.8		
-2°	1854	515	5.5		36.2	55	76.8		75
	1676.9	465.8	7.1		40.2	55	80.8		
	1397.5	388.2	8.75		43.4	55	76.8		
0°	2035.4	565.4	5.94		42.9	55	76.8		75
	1816.6	504.6	7.73		47.2	55	81.1		
	1504.4	417.9	9.39		50.1	55	76.8		
+2°	2184.5	606.8	6.42		49.8	75	76.8		75
	1956.2	543.4	8.16		53.2	75	81.8		
	1607	446.4	9.86		56.2	75	76.8		
+4°	2315.2	643.1	7.08	58.2	75	76.8	75		
	2096.3	582.3	8.73	61.3	75	81.3			
	1746.7	485.2	10.26	63.6	75	76.8			

外形安装尺寸图 Outline installation dimension drawing

500QH-40, 500QH-40D

1、井筒悬吊式安装
Suspension installation of wellbore

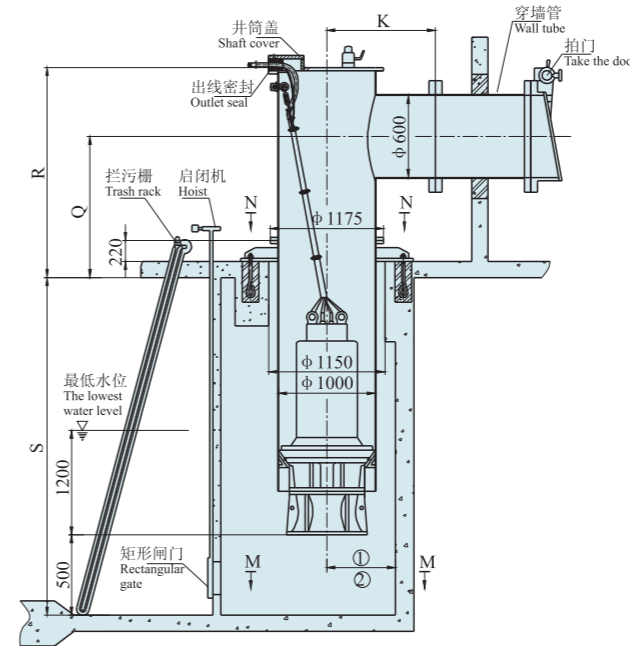

2、混凝土预制井筒式安装
Precast concrete shaft installation

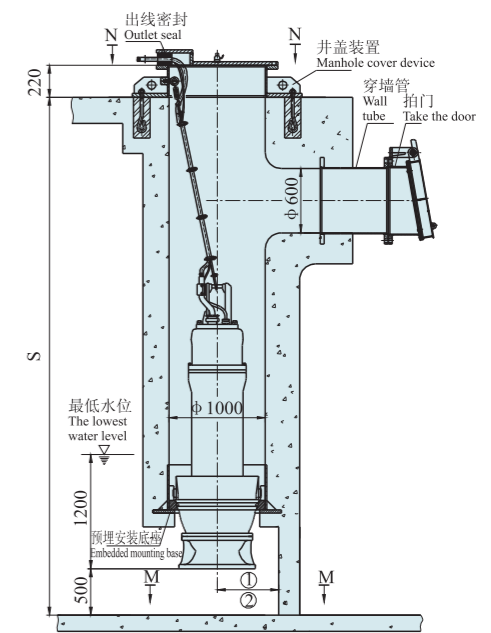

3、弯管悬吊式安装
Bend suspension installation

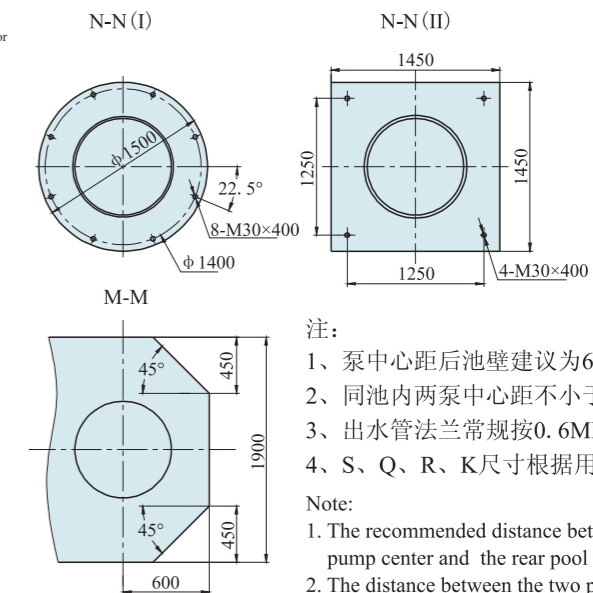
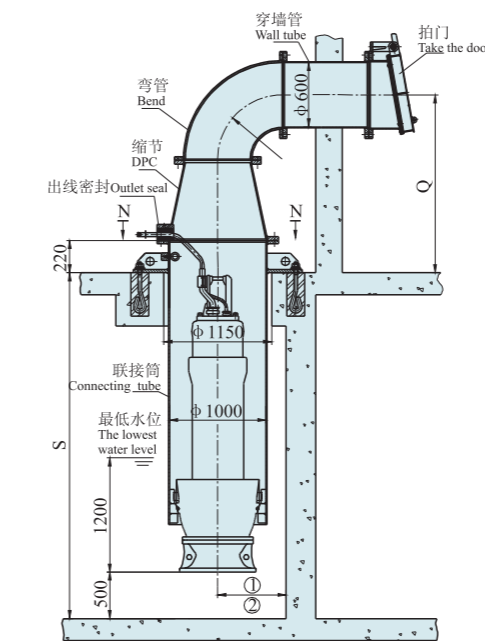

- 注:
- 1、泵中心距后池壁建议为650;
 - 2、同池内两泵中心距不小于2000;
 - 3、出水管法兰常规按0.6MPa;
 - 4、S、Q、R、K尺寸根据用户要求。
- Note:
1. The recommended distance between the pump center and the rear pool wall is 650;
 2. The distance between the two pump centers in the same pool shall not be less than 2000;
 3. The outlet pipe flange is normally 0.6mpa;
 4. Sizes of S, Q, R and K are according to user requirements.

QZ、QH型潜水轴流泵、混流泵性能曲线图与性能参数表 Curve and specification

500QH-50

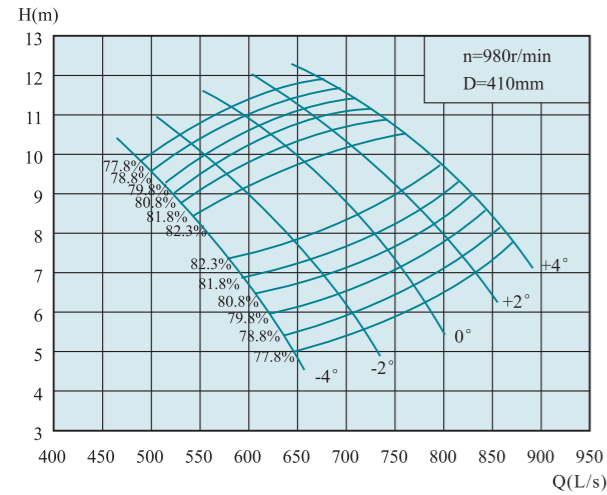

叶片安装角度 Angle	流量Q Capacity		扬程H Head (m)	转速n Speed (r/min)	功率P Power(kw)		效率η Eff. (%)	叶轮直径 Diameter of impeller (mm)	
	(m³/h)	(L/s)			轴功率 Shaft power	电机功率 Motor power			
-4°	2291.8	636.6	5.42	980	43	75	78.8	410	
	1987.6	552.1	8.28		54.2		82.8		
	1795	498.6	9.6		59.6		78.8		
-2°	2546.3	707.3	5.97		52.6		78.8		
	2173.7	603.8	8.96		64		82.9		
	1950.1	541.7	10.24		69.1		78.8		
0°	2776.3	771.2	6.65		63.8	90	78.8		
	2422.1	672.8	9.38		74.8		82.8		
	2148.8	596.9	10.96		81.4		78.8		
+2°	2950.2	819.5	7.42		75.7		110		78.8
	2546.3	707.3	10.24		85.8				82.8
	2335.3	648.7	11.43		92.3				78.8
+4°	3093.1	859.2	8.11	86.7	78.8	78.8			
	2732.8	759.1	10.58	95.2		82.8			
	2496.6	693.5	11.69	100.9		78.8			

500QH-50D

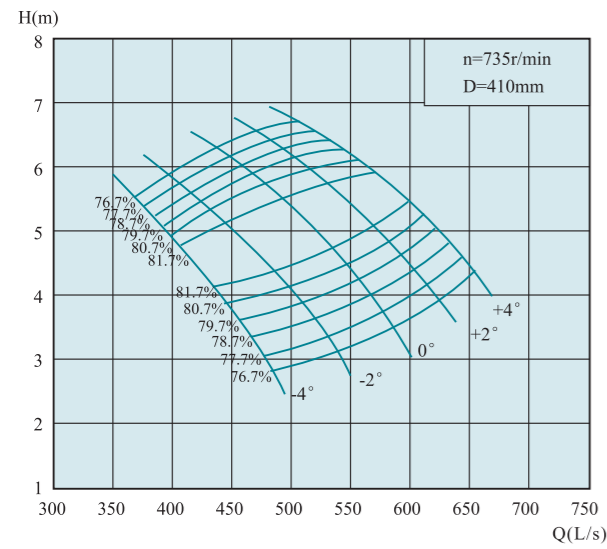

叶片安装角度 Angle	流量Q Capacity		扬程H Head (m)	转速n Speed (r/min)	功率P Power(kw)		效率η Eff. (%)	叶轮直径 Diameter of impeller (mm)	
	(m³/h)	(L/s)			轴功率 Shaft power	电机功率 Motor power			
-4°	1719	477.5	3.05	735	18.4	30	77.8	410	
	1490.8	414.1	4.66		23.1		81.8		
	1346	373.9	5.4		25.5		77.8		
-2°	1909.8	530.5	3.36		22.5		37		77.8
	1630.4	452.9	5.04		27.3				81.9
	1462.7	406.3	5.76		29.5				77.8
0°	2082.2	578.4	3.74		27.3	77.8			77.8
	1816.6	504.6	5.28		32				81.8
	1611.7	447.7	6.17		34.8				77.8
+2°	2212.6	614.6	4.18		32.4		45		77.8
	1909.8	530.5	5.76		36.6				81.8
	1751.4	486.5	6.43		39.4				77.8
+4°	2319.8	644.4	4.56	37.1	77.8	77.8			
	2049.5	569.3	5.95	40.6		81.8			
	1872.7	520.2	6.57	43.1		77.8			

QZ、QH型潜水轴流泵、混流泵性能曲线图与性能参数表 Curve and specification

500QZ-50

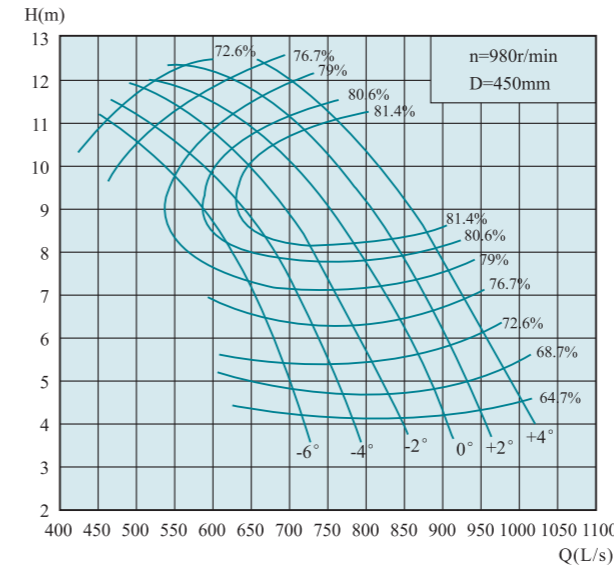

叶片安装角度 Angle	流量Q Capacity		扬程H Head (m)	转速n Speed (r/min)	功率P Power(kw)		效率η Eff. (%)	叶轮直径 Diameter of impeller (mm)	
	(m³/h)	(L/s)			轴功率 Shaft power	电机功率 Motor power			
-6°	2510.6	697.4	4.8	980	47.8	75	68.7	450	
	2118.6	588.5	8.77		62.6		80.9		
	1677.2	465.9	11.04		68.6		73.6		
-4°	2726.3	757.3	4.71		50.9		90		68.7
	2303.3	639.8	9.04		69.1				82.1
	1730.9	480.8	11.56		74.1				73.6
-2°	2943.4	817.6	4.71		55	90			68.7
	2372.8	659.1	9.31		73.3				82.1
	1816.2	504.5	11.88		79.9				73.6
0°	3178.4	882.9	4.93		62.2		110		68.7
	2635.6	732.1	9.35		81.6				82.3
	2104.6	584.6	11.72		87.6				76.7
+2°	3370.7	936.3	5.04	67.4	110	68.7			
	2774.5	770.7	9.59	88.3		82.1			
	2264.8	629.1	12.11	97.4		76.7			
+4°	3498.8	971.9	5.47	75.9		78.8	68.7		
	2917.8	810.5	9.85	95.4			82.1		
	2371.7	658.8	12.33	103.9			76.7		

500QZ-50D

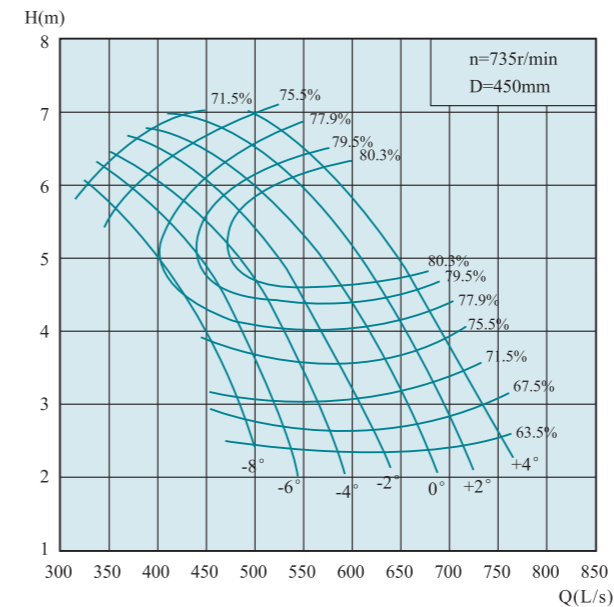

叶片安装角度 Angle	流量Q Capacity		扬程H Head (m)	转速n Speed (r/min)	功率P Power(kw)		效率η Eff. (%)	叶轮直径 Diameter of impeller (mm)	
	(m³/h)	(L/s)			轴功率 Shaft power	电机功率 Motor power			
-6°	1882.8	523	2.7	735	20.5	37	67.6	450	
	1589	441.4	4.93		26.8		79.8		
	1257.8	349.4	6.21		29.4		72.5		
-4°	2044.8	568	2.65		21.8		37		67.6
	1727.6	479.9	5.08		29.5				81
	1298.2	360.6	6.5		31.7				72.5
-2°	2207.5	613.2	2.65		23.6	45			67.6
	1779.5	494.3	5.23		31.3				81
	1362.2	378.4	6.68		34.2				72.5
0°	2383.9	662.2	2.77		26.6		45		67.6
	1976.8	549.1	5.26		34.9				81.2
	1578.6	438.5	6.59		37.5				75.6
+2°	2527.9	702.2	2.84	28.9	55	67.6			
	2080.8	578	5.39	37.7		81			
	1698.8	471.9	6.81	41.7		75.6			
+4°	2624	728.9	3.08	32.6		78.8	67.6		
	2188.1	607.8	5.54	40.8			81		
	1778.8	494.1	6.94	44.5			75.6		

QZ、QH型潜水轴流泵、混流泵性能曲线图与性能参数表 Curve and specification

500QZ-70

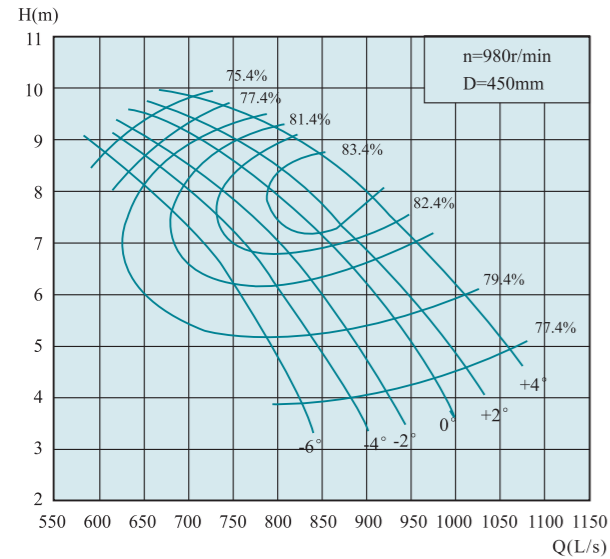

叶片安装角度 Angle	流量Q Capacity		扬程H Head (m)	转速n Speed (r/min)	功率P Power(kw)		效率η Eff. (%)	叶轮直径 Diameter of impeller (mm)	
	(m³/h)	(L/s)			轴功率 Shaft power	电机功率 Motor power			
-6°	2956.3	821.2	3.85	980	39.2	75	79.2	450	
	2627.6	729.9	6.78		58.3		83.2		
	2176.2	604.5	8.74		67.1		77.2		
-4°	3161.5	878.2	3.96		43.1		90		79.2
	2693.5	748.2	7.19		62.5				84.4
	2258.3	627.3	9.13		72.8				77.2
-2°	3325.7	923.8	4.11		47	90			79.2
	2833.2	787	7.5		68.4				84.6
	2307.6	641	9.25		75.3				77.2
0°	3489.8	969.4	4.42		53.1		90		79.2
	2948	818.9	7.83		73.4				85.7
	2364.8	656.9	9.56		79.8				77.2
+2°	3613.3	1003.7	4.62	57.4	90	79.2			
	3021.8	839.4	7.91	75.7		86.1			
	2389.7	663.8	9.66	81.5		77.2			
+4°	3793.7	1053.8	5.04	65.8		90	79.2		
	3137	871.4	8.43	84.6			85.2		
	2537.3	704.8	9.87	88.4			77.2		

500QZ-70D

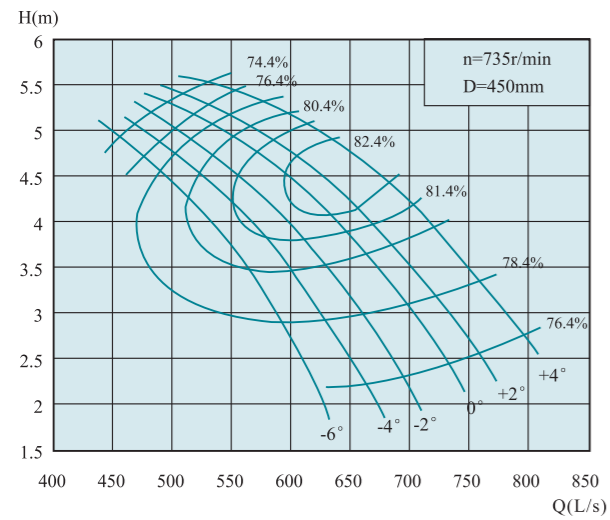

叶片安装角度 Angle	流量Q Capacity		扬程H Head (m)	转速n Speed (r/min)	功率P Power(kw)		效率η Eff. (%)	叶轮直径 Diameter of impeller (mm)	
	(m³/h)	(L/s)			轴功率 Shaft power	电机功率 Motor power			
-6°	2217.2	615.9	2.17	735	16.7	37	78.4	450	
	1970.6	547.4	3.82		24.9		82.4		
	1632.2	453.4	4.91		28.6		76.4		
-4°	2371	658.6	2.23		18.4		45		78.4
	2020	561.1	4.05		26.7				83.6
	1693.8	470.5	5.13		31				76.4
-2°	2494.4	692.9	2.31		20	45			78.4
	2124.7	590.2	4.22		29.2				83.8
	1730.5	480.7	5.2		32.1				76.4
0°	2617.6	727.1	2.49		22.7		45		78.4
	2211.1	614.2	4.41		31.3				84.9
	1773.7	492.7	5.38		34				76.4
+2°	2709.7	752.7	2.6	24.5	45	78.4			
	2266.6	629.6	4.45	32.2		85.3			
	1792.1	497.8	5.43	34.7		76.4			
+4°	2845.4	790.4	2.83	28		45	78.4		
	2352.6	653.5	4.74	36			84.4		
	1903	528.6	5.55	37.7			76.4		

QZ、QH型潜水轴流泵、混流泵性能曲线图与性能参数表 Curve and specification

500QZ-70A

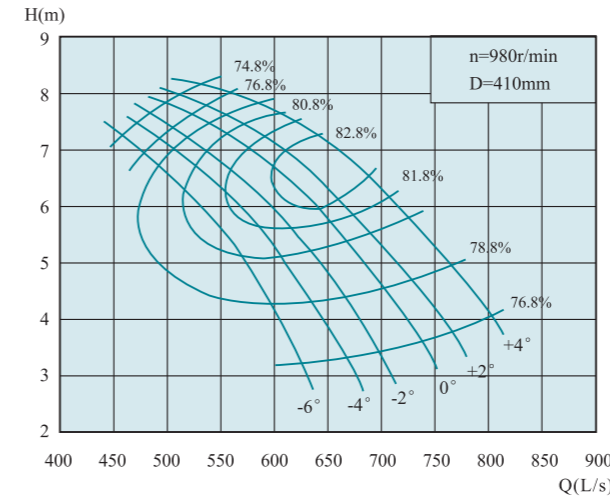

叶片安装角度 Angle	流量Q Capacity		扬程H Head (m)	转速n Speed (r/min)	功率P Power(kw)		效率η Eff. (%)	叶轮直径 Diameter of impeller (mm)	
	(m³/h)	(L/s)			轴功率 Shaft power	电机功率 Motor power			
-6°	2236	621.1	3.2	980	25.4	45	76.8	410	
	1987.6	552.1	5.63		37.7		80.8		
	1645.9	457.2	7.25		43.5		74.8		
-4°	2391.1	664.2	3.28		27.8		55		76.8
	2037.2	565.9	5.97		40.4				82
	1707.8	474.4	7.58		47.2				74.8
-2°	2515.3	698.7	3.41		30.4	55			76.8
	2142.7	595.2	6.23		44.3				82.2
	1745.3	484.8	7.68		48.8				74.8
0°	2639.5	733.2	3.67		34.4		55		76.8
	2229.8	619.4	6.5		47.4				83.3
	1788.8	496.9	7.93		51.7				74.8
+2°	2732.8	759.1	3.84	37.2	75	76.8			
	2285.6	634.9	6.57	48.9		83.7			
	1807.2	502	8.02	52.8		74.8			
+4°	2869.6	797.1	4.18	42.6		75	76.8		
	2372.4	659	7	54.7			82.8		
	1919.2	533.1	8.19	57.3			74.8		

500QZ-100

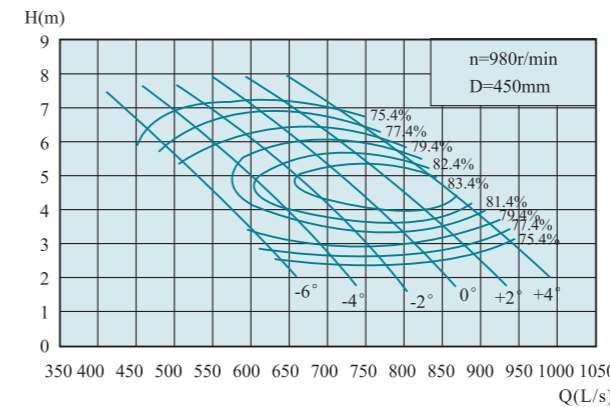

叶片安装角度 Angle	流量Q Capacity		扬程H Head (m)	转速n Speed (r/min)	功率P Power(kw)		效率η Eff. (%)	叶轮直径 Diameter of impeller (mm)	
	(m³/h)	(L/s)			轴功率 Shaft power	电机功率 Motor power			
-6°	2184.5	606.8	3.29	980	24.7	37	79.4	450	
	2053.1	570.3	4.14		28.6		81		
	1847.5	513.2	5.45		34.6		79.4		
-4°	2496.2	693.4	3.01		25.8		45		79.4
	2299.3	638.7	4.21		32				82.5
	2007.7	557.7	5.91		40.7				79.4
-2°	2718	755	2.93		27.3	55			79.4
	2504.5	695.7	4.33		35.6				83.1
	2151.4	597.6	6.2		45.8				79.4
0°	2931.5	814.3	3.02		30.4		55		79.4
	2709.7	752.7	4.32		38.2				83.4
	2311.6	642.1	6.42		50.9				79.4
+2°	3120.5	866.8	3.26	34.9	75	79.4			
	2874.2	798.4	4.55	42.5		83.9			
	2496.2	693.4	6.44	55.2		79.4			
+4°	3284.6	912.4	3.58	40.4		75	79.4		
	3079.4	855.4	4.57	45.9			83.6		
	2750.8	764.1	6.17	58.2			79.4		

QZ、QH型潜水轴流泵、混流泵性能曲线图与性能参数表 Curve and specification

500QZ-100D

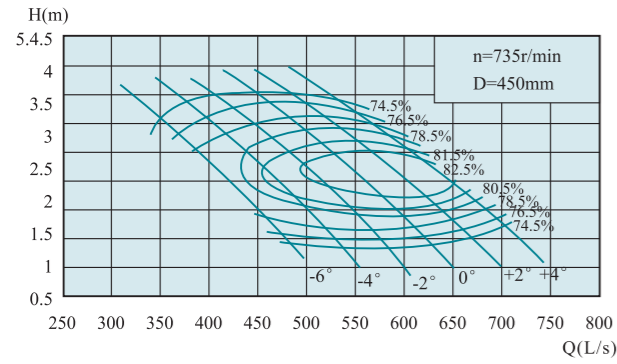

叶片安装角度 Angle	流量Q Capacity		扬程H Head (m)	转速n Speed (r/min)	功率P Power(kw)		效率η Eff. (%)	叶轮直径 Diameter of impeller (mm)
	(m³/h)	(L/s)			轴功率 Shaft power	电机功率 Motor power		
-6°	1638.4	455.1	1.85	735	10.5	18.5	78.5	450
	1539.7	427.7	2.33		12.2		80.1	
	1385.6	384.9	3.06		14.7		78.5	
-4°	1872.4	520.1	1.69		11	22	78.5	
	1724.4	479	2.37		13.6		81.6	
	1505.9	418.3	3.32		17.4		78.5	
-2°	2038.7	566.3	1.65		11.7	22	78.5	
	1878.5	521.8	2.43		15.1		82.2	
	1613.5	448.2	3.49		19.5		78.5	
0°	2198.5	610.7	1.7		13	30	78.5	
	2032.6	564.6	2.43		16.3		82.5	
	1733.8	481.6	3.61		21.7		78.5	
+2°	2340.4	650.1	1.83		14.9	30	78.5	
	2155.7	598.8	2.56		18.1		83	
	1872.4	520.1	3.62		23.5		78.5	
+4°	2463.5	684.3	2.01		17.2	30	78.5	
	2309.4	641.5	2.57		19.6		82.7	
	2063.2	573.1	3.47		24.9		78.5	

500QZ-85

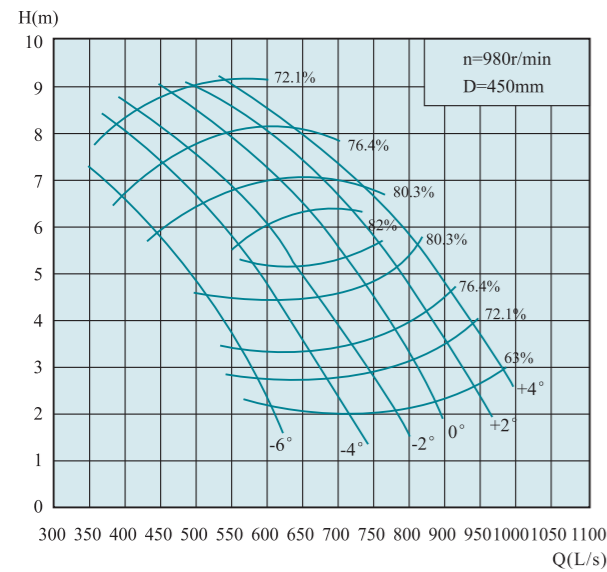

叶片安装角度 Angle	流量Q Capacity		扬程H Head (m)	转速n Speed (r/min)	功率P Power(kw)		效率η Eff. (%)	叶轮直径 Diameter of impeller (mm)
	(m³/h)	(L/s)			轴功率 Shaft power	电机功率 Motor power		
-6°	2225.5	618.2	2.87	980	24.1	45	72.2	450
	2036.5	565.7	4.36		29.8		81.2	
	1437.1	399.2	7.35		39.9		72.2	
-4°	2578.3	716.2	2.77		27	55	72.2	
	2200.7	611.3	5.34		39		82.2	
	1576.8	438	7.8		46.4		72.2	
-2°	2898.7	805.2	2.87		31.4	75	72.2	
	2504.5	695.7	5.24		43.5		82.2	
	1732.7	481.3	8.17		53.4		72.2	
0°	3120.5	866.8	3.13		36.9	75	72.2	
	2742.8	761.9	5.44		48.9		83.2	
	1905.1	529.2	8.48		61		72.2	
+2°	3334	926.1	3.6		45.3	75	72.2	
	2931.5	814.3	5.81		56.5		82.2	
	2077.6	577.1	8.73		68.5		72.2	
+4°	3547.4	985.4	4.04		54.1	90	72.2	
	2997.4	832.6	6.57		66.1		81.2	
	2266.6	629.6	8.72		74.6		72.2	

QZ、QH型潜水轴流泵、混流泵性能曲线图与性能参数表 Curve and specification

500QZ-85D

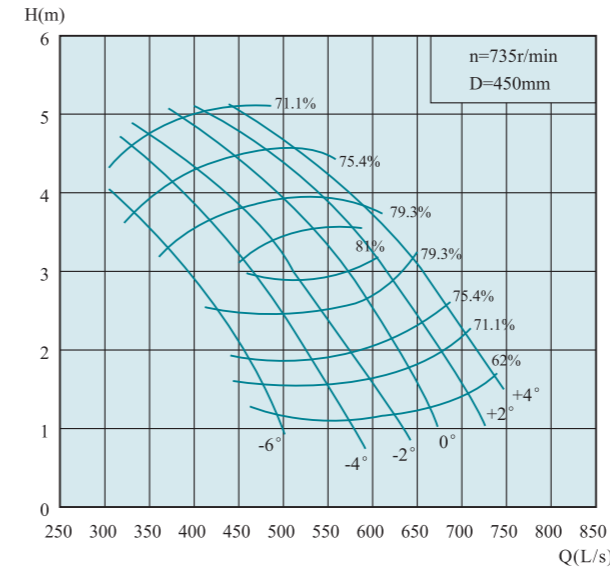

叶片安装角度 Angle	流量Q Capacity		扬程H Head (m)	转速n Speed (r/min)	功率P Power(kw)		效率η Eff. (%)	叶轮直径 Diameter of impeller (mm)
	(m³/h)	(L/s)			轴功率 Shaft power	电机功率 Motor power		
-6°	1669	463.6	1.61	735	10.3	18.5	71.2	450
	1527.5	424.3	2.45		12.7		80.2	
	1077.8	299.4	4.13		17		71.2	
-4°	1933.9	537.2	1.56		11.5	22	71.2	
	1650.6	458.5	3.01		16.7		81.2	
	1182.6	328.5	4.39		19.9		71.2	
-2°	2174	603.9	1.61		13.4	30	71.2	
	1878.5	521.8	2.95		18.6		81.2	
	1299.6	361	4.6		22.9		71.2	
0°	2340.4	650.1	1.76		15.8	30	71.2	
	2057	571.4	3.06		20.9		82.2	
	1428.8	396.9	4.77		26.1		71.2	
+2°	2500.6	694.6	2.02		19.3	37	71.2	
	2198.5	610.7	3.27		24.1		81.2	
	1558.1	432.8	4.91		29.3		71.2	
+4°	2660.8	739.1	2.27		23.1	37	71.2	
	2247.8	624.4	3.69		28.2		80.2	
	1699.9	472.2	4.9		31.9		71.2	

500QZ-125

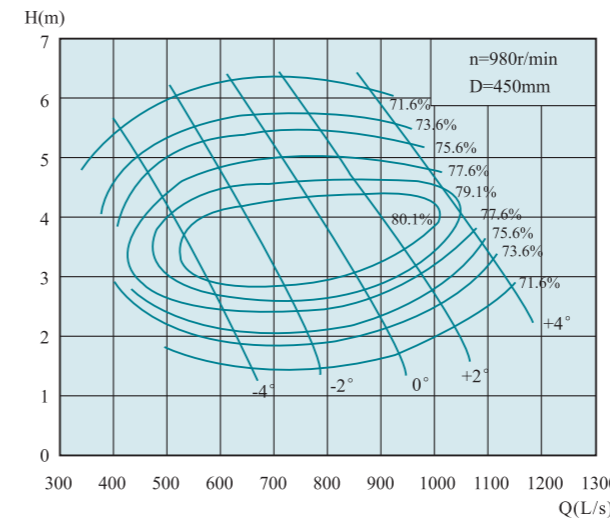

叶片安装角度 Angle	流量Q Capacity		扬程H Head (m)	转速n Speed (r/min)	功率P Power(kw)		效率η Eff. (%)	叶轮直径 Diameter of impeller (mm)
	(m³/h)	(L/s)			轴功率 Shaft power	电机功率 Motor power		
-4°	2233.4	620.4	2.1	980	16.9	37	75.6	450
	2036.5	565.7	3.11		21.5		80.1	
	1625.8	451.6	5.07		30.5		73.6	
-2°	2734.6	759.6	2.09		20.6	45	75.6	
	2521.1	700.3	3.23		27.6		80.5	
	1987.2	552	5.49		40.4		73.6	
0°	3227	896.4	2.34		27.2	55	75.6	
	2972.5	825.7	3.56		35.6		81.1	
	2389.7	663.8	5.76		51		73.6	
+2°	3588.5	996.8	2.77		35.8	75	75.6	
	3301.2	917	3.68		41.1		80.5	
	2767.3	768.7	5.76		59		73.6	
+4°	3917.2	1088.1	3.56		50.3	75	75.6	
	3752.6	1042.4	4.07		52.4		79.4	
	3350.5	930.7	5.56		69		73.6	

QZ、QH型潜水轴流泵、混流泵性能曲线图与性能参数表 Curve and specification

500QZ-125D

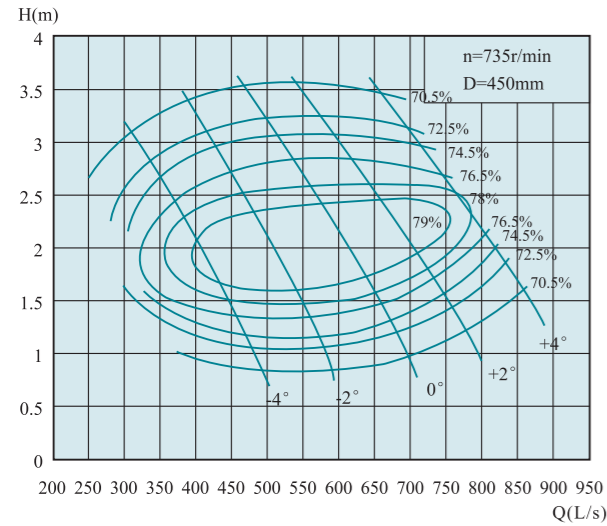

叶片安装角度 Angle	流量Q Capacity		扬程H Head (m)	转速n Speed (r/min)	功率P Power(kw)		效率η Eff. (%)	叶轮直径 Diameter of impeller (mm)	
	(m³/h)	(L/s)			轴功率 Shaft power	电机功率 Motor power			
-4°	1675.1	465.3	1.18	735	7.2	15	74.5	450	
	1527.5	424.3	1.75		9.2	15	79		
	1219.3	338.7	2.85		13.1	15	72.5		
-2°	2050.9	569.7	1.17		8.8	18.5	74.5		30
	1890.7	525.2	1.82		11.8	18.5	79.4		
0°	2420.3	672.3	1.32		11.7	21.8	74.5		30
	2229.5	619.3	2		15.2	21.8	80		
+2°	2691.4	747.6	1.56		15.4	25.3	74.5		30
	2475.7	687.7	2.07		17.6	25.3	79.4		
+4°	2937.6	816	2		21.5	29.6	74.5		30
	2814.5	781.8	2.29		22.4	29.6	78.3		
	2512.8	698	3.13		29.6	29.6	72.5		

500QZ-160

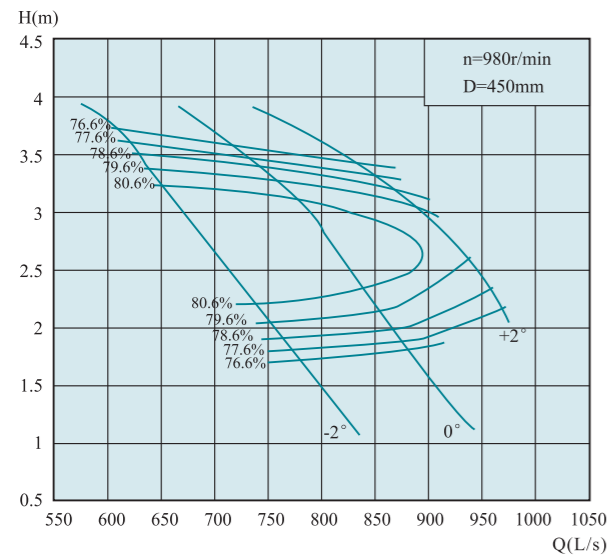

叶片安装角度 Angle	流量Q Capacity		扬程H Head (m)	转速n Speed (r/min)	功率P Power(kw)		效率η Eff. (%)	叶轮直径 Diameter of impeller (mm)	
	(m³/h)	(L/s)			轴功率 Shaft power	电机功率 Motor power			
-2°	2780.6	772.4	1.81	980	17.7	37	77.6	450	
	2545.6	707.1	2.56		21.6	37	82.1		
	2229.5	619.3	3.63		28.4	37	77.6		
0°	3142.8	873	1.87		20.6	37	77.6		37
	2956.3	821.2	2.57		25.5	37	81.1		
	2633.4	731.5	3.47		32.1	37	77.6		
+2°	3482.6	967.4	2.16		26.4	37	77.6		37
	3301.2	917	2.77		31.3	37	79.6		
	3058.2	849.5	3.32		35.7	37	77.6		

外形安装尺寸图 Outline installation dimension drawing

500QZ-50, 500QZ-70(A), 500QZ-85, 500QZ-100, 500QZ-125, 500QZ-160, 500QZ-50D, 500QZ-70D, 500QZ-85D, 500QZ-100D, 500QZ-125D, 500QH-50, 500QH-50D

1、井筒悬吊式安装
Suspension installation of wellbore

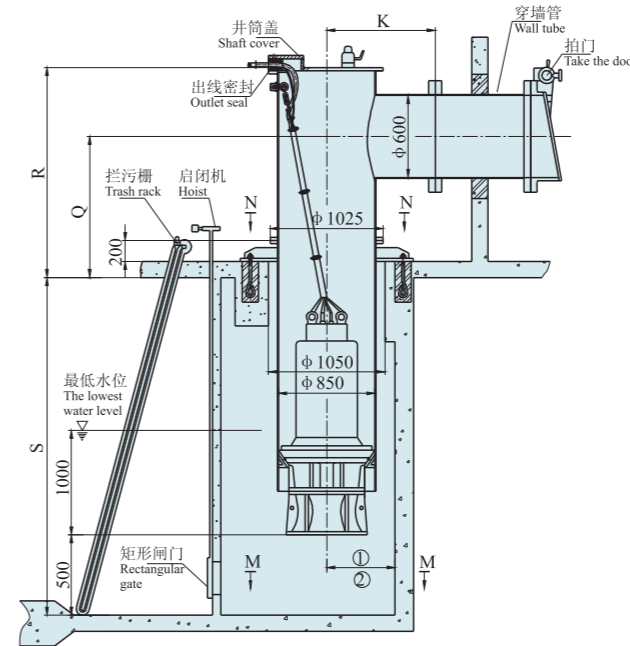

2、混凝土预制井筒式安装
Precast concrete shaft installation

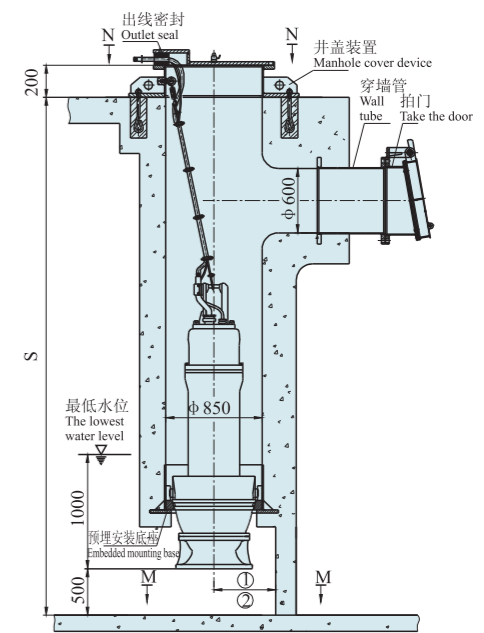

3、弯管悬吊式安装
Bend suspension installation

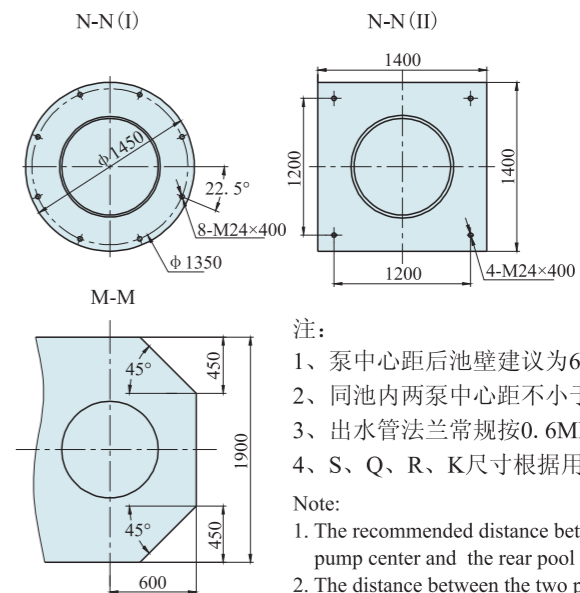
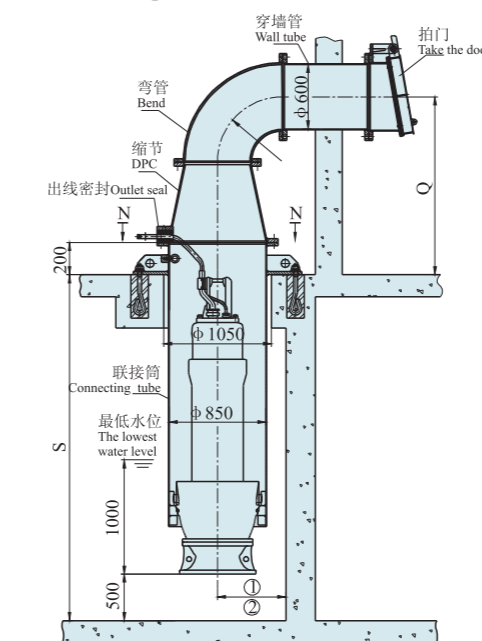

注：
1、泵中心距后池壁建议为600；
2、同池内两泵中心距不小于1900；
3、出水管法兰常规按0.6MPa；
4、S、Q、R、K尺寸根据用户要求。
Note:
1. The recommended distance between the pump center and the rear pool wall is 600;
2. The distance between the two pump centers in the same pool shall not be less than 1900;
3. The outlet pipe flange is normally 0.6mpa;
4. Sizes of S, Q, R and K are according to user requirements.

QZ、QH型潜水轴流泵、混流泵性能曲线图与性能参数表 Curve and specification

600QZ-50

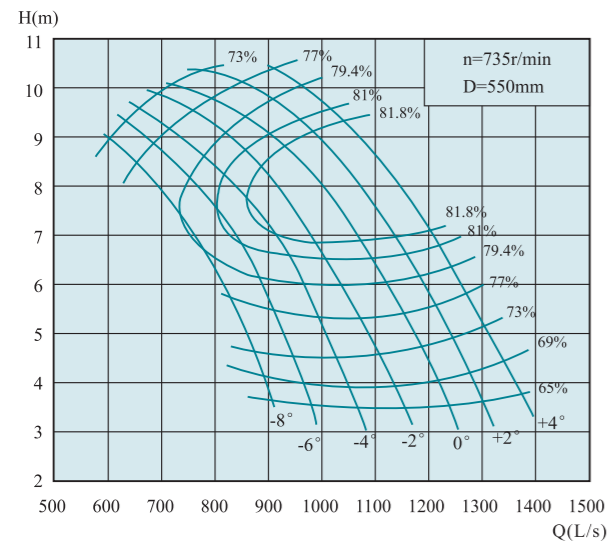

叶片安装角度 Angle	流量Q Capacity		扬程H Head (m)	转速n Speed (r/min)	功率P Power(kw)		效率η Eff. (%)	叶轮直径 Diameter of impeller (mm)	
	(m³/h)	(L/s)			轴功率 Shaft power	电机功率 Motor power			
-6°	3438	955	4.03	735	54.6	90	69.1	550	
	2900.9	805.8	7.37		71.7				
	2296.8	638	9.28		78.5				
-4°	3733.6	1037.1	3.96		58.3		110		69.1
	3154	876.1	7.59		79.1				
	2369.9	658.3	9.71		84.7				
-2°	4030.6	1119.6	3.96		62.9	132			69.1
	3249	902.5	7.82		83.9				
	2486.9	690.8	9.99		91.5				
0°	4352.4	1209	4.14		71.1		90		69.1
	3609	1002.5	7.86		93.5				
	2882.2	800.6	9.84		100.2				
+2°	4615.6	1282.1	4.24	77.2	90	69.1			
	3799.1	1055.3	8.05	101					
	3101.4	861.5	10.17	111.5					
+4°	4791.2	1330.9	4.6	86.9		90	69.1		
	3995.3	1109.8	8.28	109.3					
	3247.6	902.1	10.36	118.9					

600QZ-70

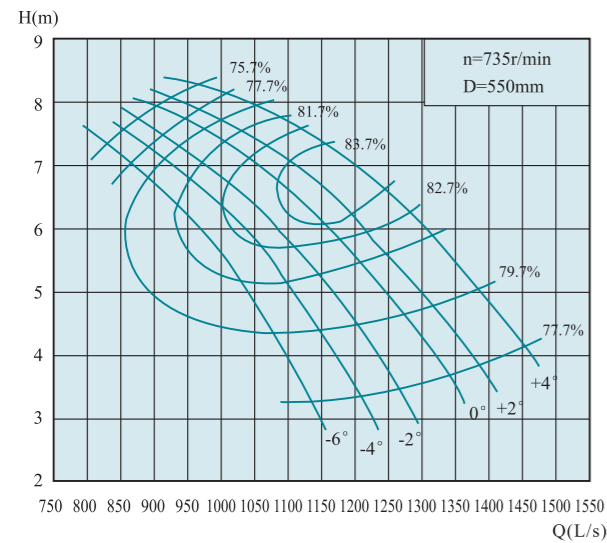

叶片安装角度 Angle	流量Q Capacity		扬程H Head (m)	转速n Speed (r/min)	功率P Power(kw)		效率η Eff. (%)	叶轮直径 Diameter of impeller (mm)	
	(m³/h)	(L/s)			轴功率 Shaft power	电机功率 Motor power			
-6°	4048.2	1124.5	3.24	735	46	90	77.7	550	
	3598.2	999.5	5.7		68.4				
	2979.7	827.7	7.34		78.7				
-4°	4329.4	1202.6	3.32		50.4		110		77.7
	3688.2	1024.5	6.05		73.3				
	3092.4	859	7.67		85.4				
-2°	4554	1265	3.45		55.1	132			77.7
	3879.4	1077.6	6.3		80.1				
	3159.7	877.7	7.77		88.4				
0°	4779	1327.5	3.71		62.2		90		77.7
	4036.7	1121.3	6.58		86				
	3238.6	899.6	8.03		93.6				
+2°	4947.5	1374.3	3.89	67.5	90	77.7			
	4138.2	1149.5	6.65	88.6					
	3272	908.9	8.12	95.6					
+4°	5195.2	1443.1	4.23	77.1		90	77.7		
	4295.5	1193.2	7.08	99					
	3474.7	965.2	8.29	103.7					

QZ、QH型潜水轴流泵、混流泵性能曲线图与性能参数表 Curve and specification

600QZ-85

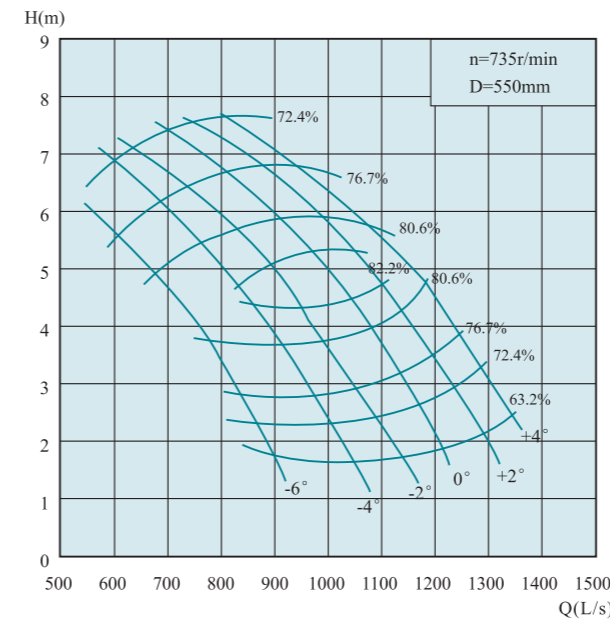

叶片安装角度 Angle	流量Q Capacity		扬程H Head (m)	转速n Speed (r/min)	功率P Power(kw)		效率η Eff. (%)	叶轮直径 Diameter of impeller (mm)	
	(m³/h)	(L/s)			轴功率 Shaft power	电机功率 Motor power			
-6°	3047.4	846.5	2.41	735	27.6	55	72.5	550	
	2788.6	774.6	3.66		34.1				
	1967.8	546.6	6.17		45.6				
-4°	3530.9	980.8	2.33		30.9		75		72.5
	3013.6	837.1	4.49		44.7				
	2158.9	599.7	6.55		53.2				
-2°	3969.4	1102.6	2.41		36	90			72.5
	3429.7	952.7	4.4		49.8				
	2372.8	659.1	6.87		61.3				
0°	4272.8	1186.9	2.63		42.2		90		72.5
	3755.9	1043.3	4.57		56				
	2608.9	724.7	7.12		69.8				
+2°	4565.2	1268.1	3.02	51.8	90	72.5			
	4014.4	1115.1	4.88	64.7					
	2844.7	790.2	7.33	78.4					
+4°	4857.8	1349.4	3.39	61.9		90	72.5		
	4104.4	1140.1	5.52	75.8					
	3103.6	862.1	7.32	85.4					

600QZ-100

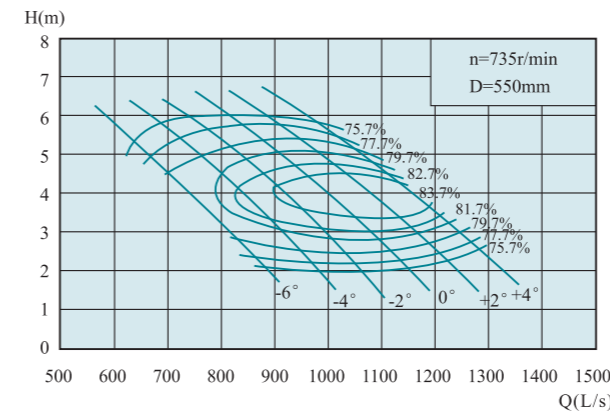

叶片安装角度 Angle	流量Q Capacity		扬程H Head (m)	转速n Speed (r/min)	功率P Power(kw)		效率η Eff. (%)	叶轮直径 Diameter of impeller (mm)	
	(m³/h)	(L/s)			轴功率 Shaft power	电机功率 Motor power			
-6°	2991.2	830.9	2.76	735	28.2	45	79.8	550	
	2811.2	780.9	3.48		32.8				
	2530.1	702.8	4.58		39.6				
-4°	3418.2	949.5	2.53		29.5		55		79.8
	3148.6	874.6	3.54		36.6				
	2749.3	763.7	4.97		46.7				
-2°	3722	1033.9	2.46		31.3	75			79.8
	3429.7	952.7	3.64		40.7				
	2946.2	818.4	5.21		52.4				
0°	4014.4	1115.1	2.54		34.8		75		79.8
	3710.9	1030.8	3.63		43.8				
	3165.5	879.3	5.4		58.4				
+2°	4272.8	1186.9	2.74	40	75	79.8			
	3935.5	1093.2	3.83	48.7					
	3418.2	949.5	5.41	63.1					
+4°	4497.8	1249.4	3.01	46.2		75	79.8		
	4216.7	1171.3	3.84	52.5					
	3767	1046.4	5.18	66.6					

QZ、QH型潜水轴流泵、混流泵性能曲线图与性能参数表 Curve and specification

600QZ-125

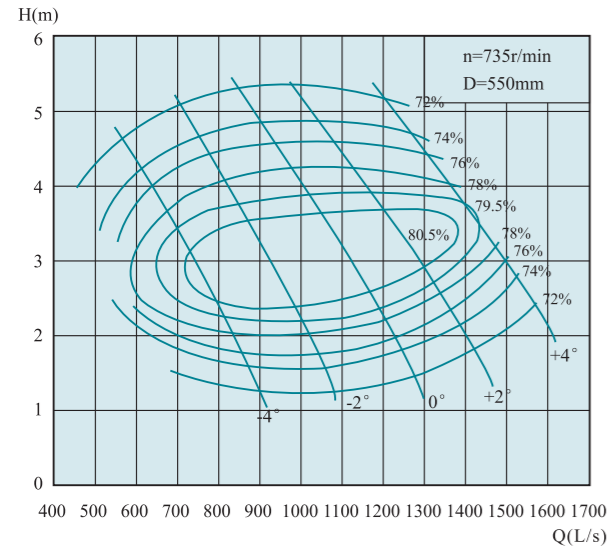

叶片安装角度 Angle	流量Q Capacity		扬程H Head (m)	转速n Speed (r/min)	功率P Power(kw)		效率η Eff. (%)	叶轮直径 Diameter of impeller (mm)	
	(m³/h)	(L/s)			轴功率 Shaft power	电机功率 Motor power			
-4°	3058.6	849.6	1.76	735	19.3	37	76.1	550	
	2788.6	774.6	2.62		24.7		80.6		
	2226.6	618.5	4.26		34.9		74.1		
-2°	3744.4	1040.1	1.75		23.5	55	76.1		
	3452	958.9	2.71		31.5		81		
	2721.2	755.9	4.61		46.1		74.1		
0°	4419	1227.5	1.97		31.2	75	76.1		
	4070.5	1130.7	2.99		40.6				81.6
	3272	908.9	4.84		58.2				74.1
+2°	4914	1365	2.33		41				76.1
	4520.5	1255.7	3.09		47				81
	3789.4	1052.6	4.84		67.4				74.1
+4°	5363.6	1489.9	2.99	57.4	90	76.1			
	5138.6	1427.4	3.42	59.9			79.9		
	4587.8	1274.4	4.67	78.8			74.1		

600QZ-160

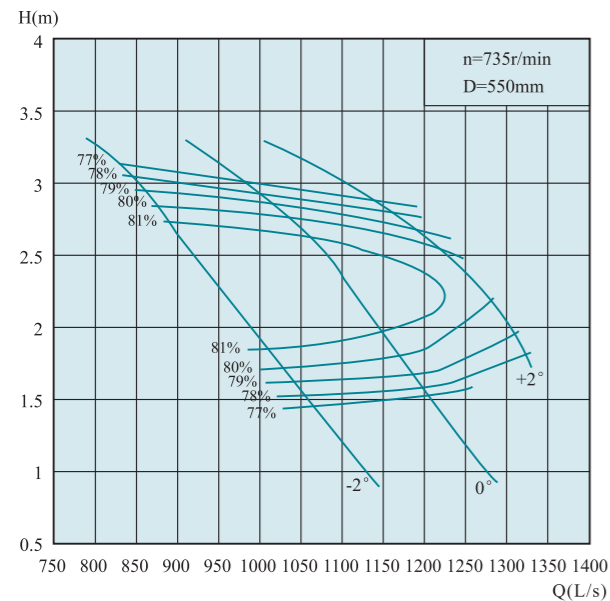

叶片安装角度 Angle	流量Q Capacity		扬程H Head (m)	转速n Speed (r/min)	功率P Power(kw)		效率η Eff. (%)	叶轮直径 Diameter of impeller (mm)	
	(m³/h)	(L/s)			轴功率 Shaft power	电机功率 Motor power			
-2°	3807.7	1057.7	1.52	735	20.2	37	78	550	
	3485.9	968.3	2.15		24.8				82.5
	3052.8	848	3.05		32.5				78
0°	4303.8	1195.5	1.57		23.6	45	78		
	4048.2	1124.5	2.16		29.2				81.5
	3605.8	1001.6	2.92		36.8				78
+2°	4768.9	1324.7	1.81		30.2				78
	4520.5	1255.7	2.33		35.9				80
	4187.9	1163.3	2.79		40.8				78

QZ、QH型潜水轴流泵、混流泵性能曲线图与性能参数表 Curve and specification

600QH-40

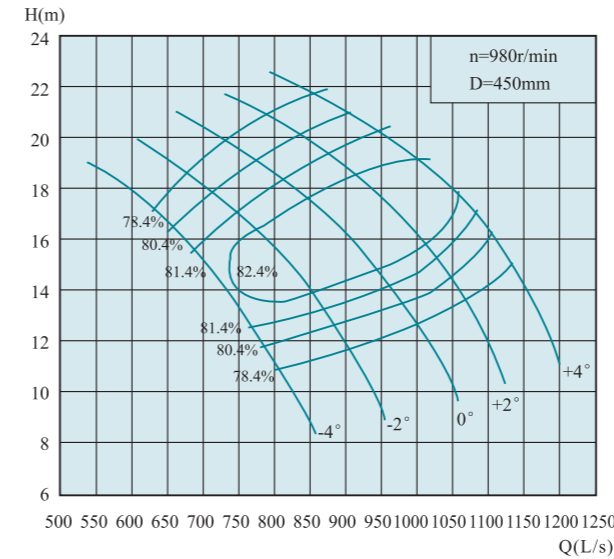

叶片安装角度 Angle	流量Q Capacity		扬程H Head (m)	转速n Speed (r/min)	功率P Power(kw)		效率η Eff. (%)	叶轮直径 Diameter of impeller (mm)	
	(m³/h)	(L/s)			轴功率 Shaft power	电机功率 Motor power			
-4°	2915.3	809.8	10.93	980	110.8	160	78.4	450	
	2668.7	741.3	14.03		124.1				82.2
	2291	636.4	17.37		138.3				78.4
-2°	3268.4	907.9	11.78		133.8	185	78.4		
	2956.3	821.2	15.21		148.7				82.4
	2463.5	684.3	18.74		160.5				78.4
0°	3588.5	996.8	12.71		158.5	200	78.4		
	3202.6	889.6	16.55		174.6				82.7
	2652.5	736.8	20.11		185.4				78.4
+2°	3851.3	1069.8	13.75		184.1	220	78.4		
	3448.8	958	17.47		196.9				83.4
	2833.2	787	21.12		208				78.4
+4°	4081.3	1133.7	15.16	215.1	250	78.4			
	3695.4	1026.5	18.71	227.3			82.9		
	3079.4	855.4	21.97	235.2			78.4		

600QH-40D

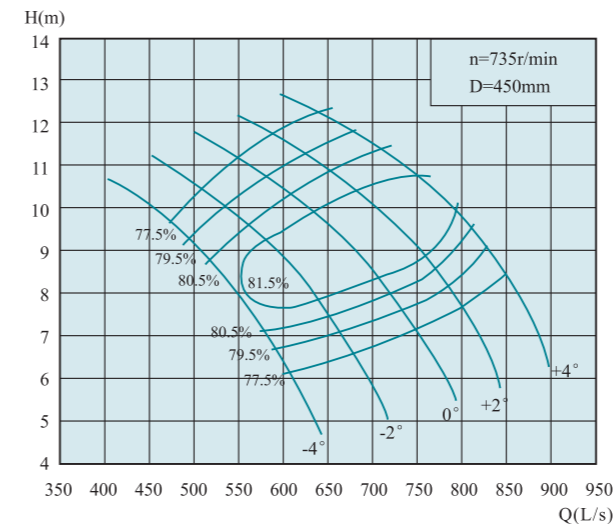

叶片安装角度 Angle	流量Q Capacity		扬程H Head (m)	转速n Speed (r/min)	功率P Power(kw)		效率η Eff. (%)	叶轮直径 Diameter of impeller (mm)	
	(m³/h)	(L/s)			轴功率 Shaft power	电机功率 Motor power			
-4°	2186.3	607.3	6.15	735	47.3	75	77.5	450	
	2001.6	556	7.89		52.9				81.3
	1718.3	477.3	9.77		59				77.5
-2°	2451.2	680.9	6.63		57.1	90	77.5		
	2217.2	615.9	8.56		63.5				81.5
	1847.5	513.2	10.54		68.5				77.5
0°	2691.4	747.6	7.15		67.7	110	77.5		
	2401.9	667.2	9.31		74.5				81.8
	1989.4	552.6	11.31		79.1				77.5
+2°	2888.6	802.4	7.74		78.6	110	77.5		
	2586.6	718.5	9.83		84				82.5
	2124.7	590.2	11.88		88.8				77.5
+4°	3061.1	850.3	8.53	91.8	110	77.5			
	2771.3	769.8	10.52	96.9			82		
	2309.4	641.5	12.36	100.4			77.5		

QZ、QH型潜水轴流泵、混流泵性能曲线图与性能参数表 Curve and specification

600QH-50

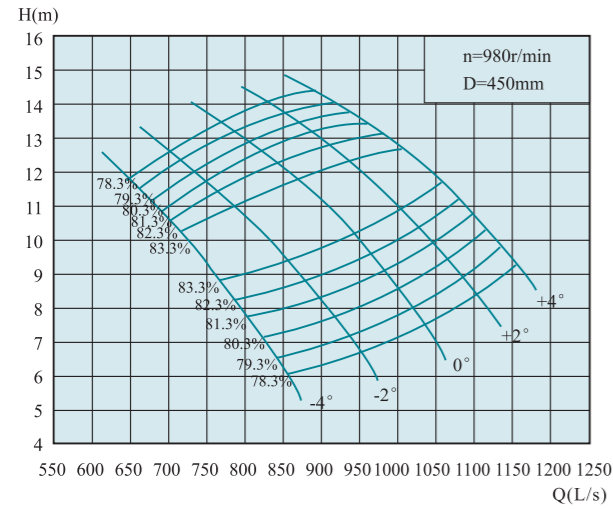

叶片安装角度 Angle	流量Q Capacity		扬程H Head (m)	转速n Speed (r/min)	功率P Power(kw)		效率η Eff. (%)	叶轮直径 Diameter of impeller (mm)	
	(m³/h)	(L/s)			轴功率 Shaft power	电机功率 Motor power			
-4°	3030.1	841.7	6.53	980	67.9	110	75.6	450	
	2627.6	729.9	9.97		85.6	110	79.4		
	2373.1	659.2	11.56		94.2	110	75.6		
-2°	3366.7	935.2	7.19		83.1	132	75.6		
	2874.2	798.4	10.79		101.2		79.6		
	2578.3	716.2	12.33		109.1		75.6		
0°	3670.6	1019.6	8.02		101	160	75.6		
	3202.6	889.6	11.31		118.3		79.9		
	2841.1	789.2	13.21		128.8		75.6		
+2°	3900.6	1083.5	8.94		119.7	185	75.6		
	3366.7	935.2	12.33		135.6		80.6		
	3087.7	857.7	13.77		145.9		75.6		
+4°	4089.6	1136	9.76	137		75.6			
	3613.3	1003.7	12.74	150.4		80.1			
	3301.2	917	14.08	159.5		75.6			

600QH-50D

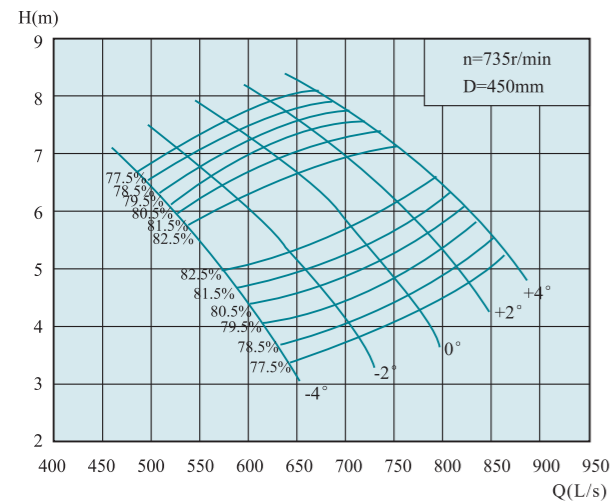

叶片安装角度 Angle	流量Q Capacity		扬程H Head (m)	转速n Speed (r/min)	功率P Power(kw)		效率η Eff. (%)	叶轮直径 Diameter of impeller (mm)	
	(m³/h)	(L/s)			轴功率 Shaft power	电机功率 Motor power			
-4°	2272.7	631.3	3.67	735	29	45	78.5	450	
	1970.6	547.4	5.61		36.5	45	82.5		
	1779.8	494.4	6.5		40.2	45	78.5		
-2°	2525	701.4	4.05		35.5	55	78.5		
	2155.7	598.8	6.07		43.2		82.6		
	1933.9	537.2	6.94		46.6		78.5		
0°	2752.9	764.7	4.51		43.1	75	78.5		
	2401.9	667.2	6.36		50.5		82.5		
	2130.8	591.9	7.43		55		78.5		
+2°	2925.4	812.6	5.03		51.1		78.5		
	2525	701.4	6.94		57.9		82.5		
	2315.9	643.3	7.75		62.3		78.5		
+4°	3067.2	852	5.49	58.5		78.5			
	2709.7	752.7	7.17	64.2		82.5			
	2475.7	687.7	7.92	68.1		78.5			

外形安装尺寸图 Outline installation dimension drawing

600QZ-50, 600QZ-70, 600QZ-85, 600QZ-100, 600QZ-125, 600QZ-160
600QH-40, 600QH-40D, 600QH-50, 600QH-50D

1、井筒悬吊式安装
Suspension installation of wellbore

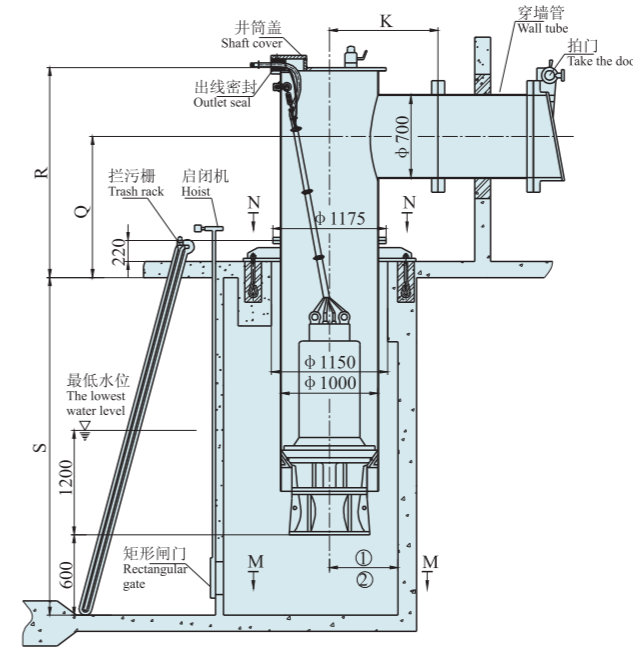

2、混凝土预制井筒式安装
Precast concrete shaft installation

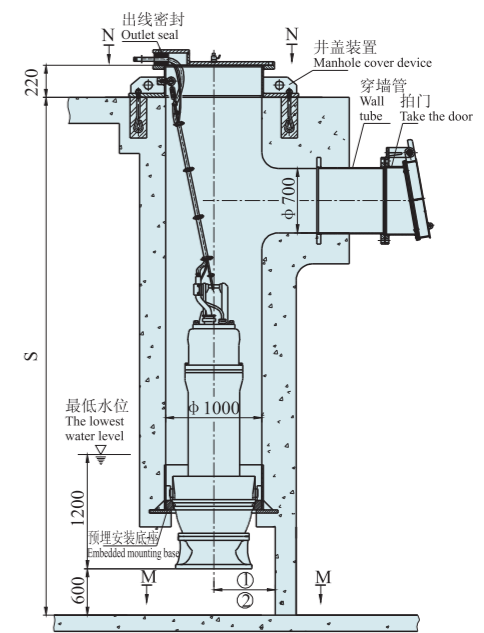

3、弯管悬吊式安装
Bend suspension installation

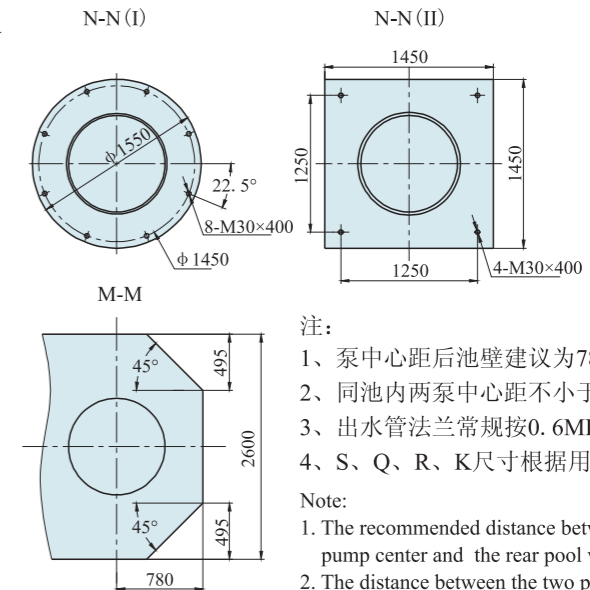
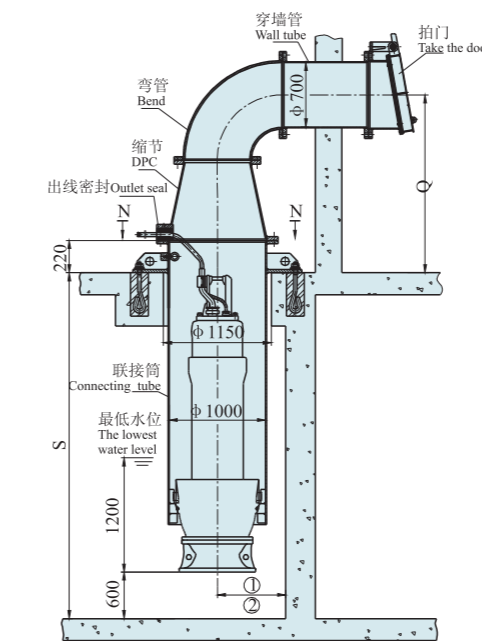

- 注:
- 1、泵中心距后池壁建议为780;
 - 2、同池内两泵中心距不小于2600;
 - 3、出水管法兰常规按0.6MPa;
 - 4、S、Q、R、K尺寸根据用户要求。
- Note:
1. The recommended distance between the pump center and the rear pool wall is 780;
 2. The distance between the two pump centers in the same pool shall not be less than 2600;
 3. The outlet pipe flange is normally 0.6mpa;
 4. Sizes of S, Q, R and K are according to user requirements.

QZ、QH型潜水轴流泵、混流泵性能曲线图与性能参数表 Curve and specification

700QZ-50

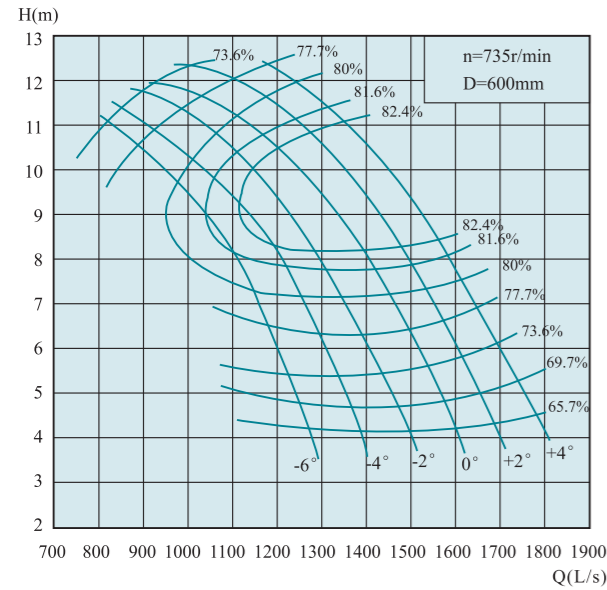

叶片安装角度 Angle	流量Q Capacity		扬程H Head (m)	转速n Speed (r/min)	功率P Power(kw)		效率η Eff. (%)	叶轮直径 Diameter of impeller (mm)	
	(m³/h)	(L/s)			轴功率 Shaft power	电机功率 Motor power			
-6°	4463.3	1239.8	4.8	735	83.8	132	69.7	600	
	3766.3	1046.2	8.77		109.9		81.9		
	2981.9	828.3	11.04		120.3		74.6		
-4°	4847	1346.4	4.71		89.3	160	69.7		600
	4095	1137.5	9.04		121.4		83.1		
	3076.9	854.7	11.56		129.9		74.6		
-2°	5232.6	1453.5	4.71		96.4	160	69.7		600
	4218.5	1171.8	9.31		128.8		83.1		
	3228.8	896.9	11.88		140.1		74.6		
0°	5650.6	1569.6	4.93		108.9	185	69.7		600
	4685.4	1301.5	9.35		143.3		83.3		
	3741.5	1039.3	11.72		153.8		77.7		
+2°	5992.2	1664.5	5.04	118.1	185	69.7	600		
	4932.4	1370.1	9.59	155.1		83.1			
	4026.6	1118.5	12.11	171		77.7			
+4°	6220.1	1727.8	5.47	133	200	69.7	600		
	5186.9	1440.8	9.85	167.5		83.1			
	4216.3	1171.2	12.33	182.3		77.7			

QZ、QH型潜水轴流泵、混流泵性能曲线图与性能参数表 Curve and specification

700QZ-70

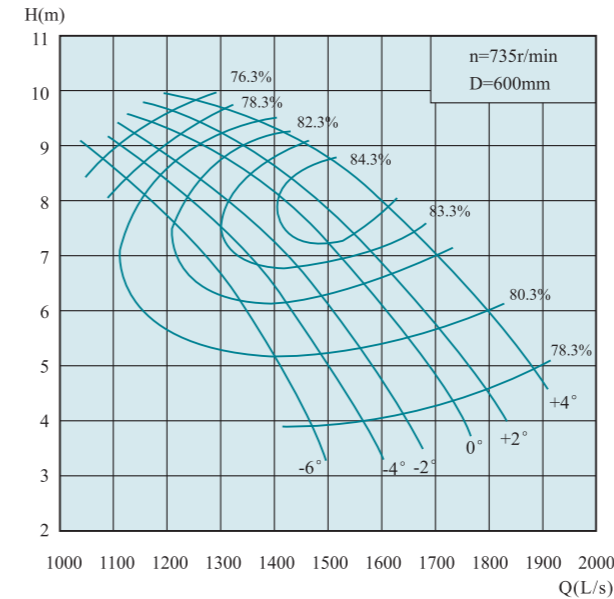

叶片安装角度 Angle	流量Q Capacity		扬程H Head (m)	转速n Speed (r/min)	功率P Power(kw)		效率η Eff. (%)	叶轮直径 Diameter of impeller (mm)	
	(m³/h)	(L/s)			轴功率 Shaft power	电机功率 Motor power			
-6°	5255.6	1459.9	3.85	735	70.4	132	78.3	600	
	4671.7	1297.7	6.78		104.9		82.3		
	3868.6	1074.6	8.74		120.8		76.3		
-4°	5620.3	1561.2	3.96		77.5	160	78.3		600
	4788.4	1330.1	7.19		112.4		83.5		
	4014.7	1115.2	9.13		130.9		76.3		
-2°	5912.3	1642.3	4.11		84.6	160	78.3		600
	5036.4	1399	7.5		123		83.7		
	4102.2	1139.5	9.25		135.5		76.3		
0°	6204.2	1723.4	4.42		95.4	160	78.3		600
	5240.9	1455.8	7.83		131.9		84.8		
	4204.4	1167.9	9.56		143.6		76.3		
+2°	6423.5	1784.3	4.62	103.3	185	78.3	600		
	5372.3	1492.3	7.91	135.9		85.2			
	4248.4	1180.1	9.66	146.6		76.3			
+4°	6744.6	1873.5	5.04	118.3	185	78.3	600		
	5576.8	1549.1	8.43	152		84.3			
	4510.8	1253	9.87	159		76.3			

700QZ-50D

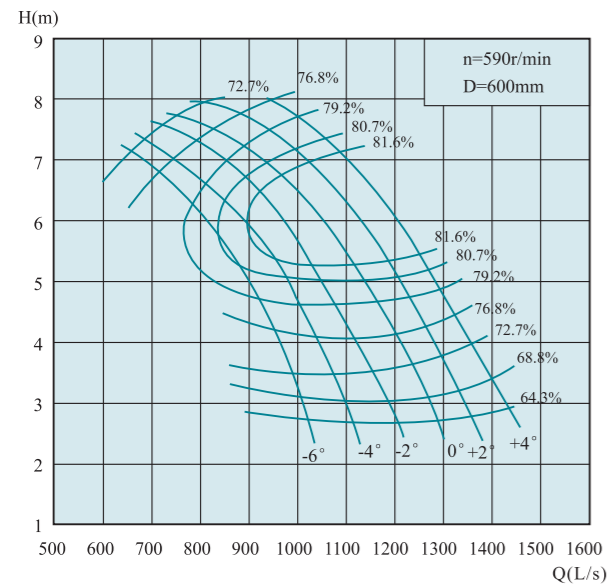

叶片安装角度 Angle	流量Q Capacity		扬程H Head (m)	转速n Speed (r/min)	功率P Power(kw)		效率η Eff. (%)	叶轮直径 Diameter of impeller (mm)	
	(m³/h)	(L/s)			轴功率 Shaft power	电机功率 Motor power			
-6°	3582.7	995.2	3.09	590	43.8	75	68.9	600	
	3023.3	839.8	5.65		57.4		81.1		
	2393.6	664.9	7.12		62.9		73.8		
-4°	3890.9	1080.8	3.03		46.6	75	68.9		600
	3287.2	913.1	5.82		63.3		82.3		
	2470	686.1	7.45		67.9		73.8		
-2°	4200.1	1166.7	3.03		50.3	90	68.9		600
	3386.2	940.6	6		67.3		82.3		
	2591.6	719.9	7.66		73.3		73.8		
0°	4535.6	1259.9	3.18		57	90	68.9		600
	3761.3	1044.8	6.02		74.8		82.5		
	3003.5	834.3	7.55		80.4		76.9		
+2°	4810	1336.1	3.25	61.8	110	68.9	600		
	3959.3	1099.8	6.18	81		82.3			
	3232.1	897.8	7.8	89.3		76.9			
+4°	4993.2	1387	3.53	69.7	110	68.9	600		
	4163.8	1156.6	6.35	87.5		82.3			
	3384.7	940.2	7.95	95.4		76.9			

700QZ-70D

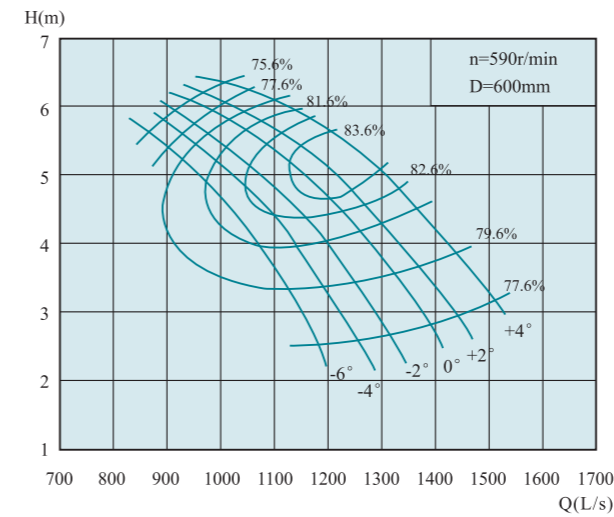

叶片安装角度 Angle	流量Q Capacity		扬程H Head (m)	转速n Speed (r/min)	功率P Power(kw)		效率η Eff. (%)	叶轮直径 Diameter of impeller (mm)	
	(m³/h)	(L/s)			轴功率 Shaft power	电机功率 Motor power			
-6°	4218.8	1171.9	2.48	590	36.7	75	77.6	600	
	3750.1	1041.7	4.37		54.7		81.6		
	3105.4	862.6	5.63		63		75.6		
-4°	4511.5	1253.2	2.55		40.4	75	77.6		600
	3843.7	1067.7	4.64		58.7		82.8		
	3222.7	895.2	5.88		68.3		75.6		
-2°	4745.9	1318.3	2.65		44.2	90	77.6		600
	4042.8	1123	4.83		64.1		83		
	3292.9	914.7	5.96		70.7		75.6		
0°	4980.2	1383.4	2.85		49.8	90	77.6		600
	4207	1168.6	5.05		68.8		84.1		
	3375	937.5	6.16		74.9		75.6		
+2°	5156.3	1432.3	2.98	54	90	77.6	600		
	4312.4	1197.9	5.1	70.9		84.6			
	3410.3	947.3	6.23	76.6		75.6			
+4°	5414	1503.9	3.25	61.8	110	77.6	600		
	4476.6	1243.5	5.43	79.2		83.6			
	3620.9	1005.8	6.36	83		75.6			

QZ、QH型潜水轴流泵、混流泵性能曲线图与性能参数表 Curve and specification

700QZ-85

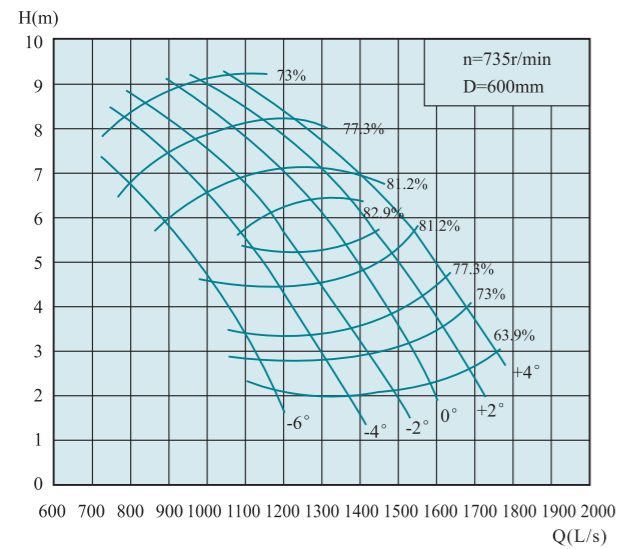

叶片安装角度 Angle	流量Q Capacity		扬程H Head (m)	转速n Speed (r/min)	功率P Power(kw)		效率η Eff. (%)	叶轮直径 Diameter of impeller (mm)	
	(m³/h)	(L/s)			轴功率 Shaft power	电机功率 Motor power			
-6°	3956.4	1099	2.87	735	42.3	75	73.1	600	
	3620.5	1005.7	4.36		52.4		82.1		
	2554.9	709.7	7.35		70		73.1		
-4°	4583.9	1273.3	2.77		47.3	90	73.1		600
	3912.5	1086.8	5.34		68.5		83.1		
	2803	778.6	7.8		81.5		73.1		
-2°	5153.4	1431.5	2.87		55.1	110	73.1		600
	4452.5	1236.8	5.24		76.5		83.1		
	3080.2	855.6	8.17		93.8		73.1		
0°	5547.6	1541	3.13		64.7	110	73.1		600
	4875.8	1354.4	5.44		85.9		84.1		
	3386.9	940.8	8.48		107.1		73.1		
+2°	5927	1646.4	3.6	79.5	132	73.1	600		
	5211.7	1447.7	5.81	99.3		83.1			
	3693.6	1026	8.73	120.2		73.1			
+4°	6306.5	1751.8	4.04	95	160	73.1	600		
	5328.4	1480.1	6.57	116.2		82.1			
	4029.1	1119.2	8.72	131		73.1			

QZ、QH型潜水轴流泵、混流泵性能曲线图与性能参数表 Curve and specification

700QZ-100

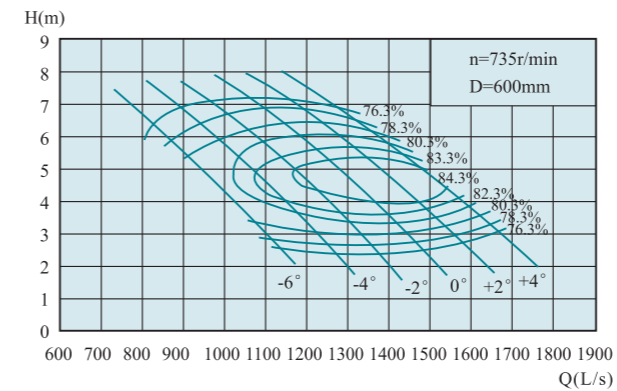

叶片安装角度 Angle	流量Q Capacity		扬程H Head (m)	转速n Speed (r/min)	功率P Power(kw)		效率η Eff. (%)	叶轮直径 Diameter of impeller (mm)	
	(m³/h)	(L/s)			轴功率 Shaft power	电机功率 Motor power			
-6°	3883.3	1078.7	3.29	735	43.4	75	80.3	600	
	3649.7	1013.8	4.14		50.3		81.9		
	3284.6	912.4	5.45		60.7		80.3		
-4°	4438.1	1232.8	3.01		45.3	90	80.3		600
	4087.4	1135.4	4.21		56.2		83.4		
	3569.4	991.5	5.91		71.6		80.3		
-2°	4832.3	1342.3	2.93		48	90	80.3		600
	4452.5	1236.8	4.33		62.5		84		
	3825	1062.5	6.2		80.5		80.3		
0°	5211.7	1447.7	3.02		53.4	110	80.3		600
	4817.5	1338.2	4.32		67.3		84.3		
	4109.4	1141.5	6.42		89.5		80.3		
+2°	5547.6	1541	3.26	61.4	110	80.3	600		
	5109.5	1419.3	4.55	74.7		84.8			
	4438.1	1232.8	6.44	97		80.3			
+4°	5839.6	1622.1	3.58	70.9	160	80.3	600		
	5474.5	1520.7	4.57	80.7		84.5			
	4890.6	1358.5	6.17	102.4		80.3			

700QZ-85D

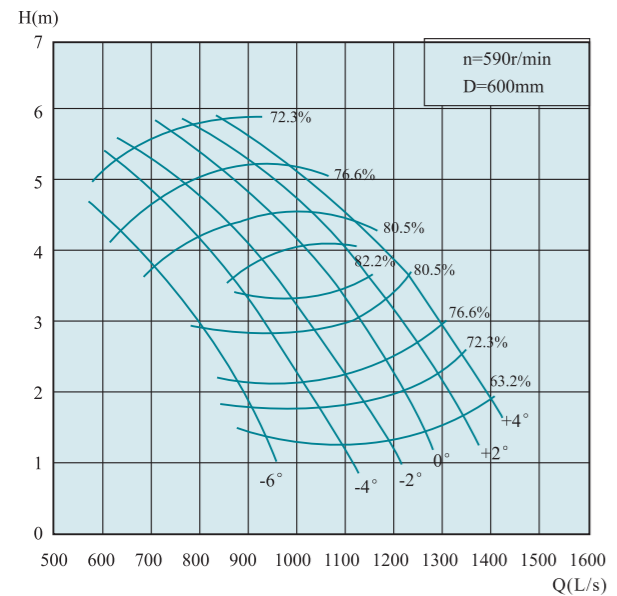

叶片安装角度 Angle	流量Q Capacity		扬程H Head (m)	转速n Speed (r/min)	功率P Power(kw)		效率η Eff. (%)	叶轮直径 Diameter of impeller (mm)	
	(m³/h)	(L/s)			轴功率 Shaft power	电机功率 Motor power			
-6°	3175.9	882.2	1.85	590	22.1	45	72.4	600	
	2906.3	807.3	2.81		27.3		81.4		
	2050.9	569.7	4.74		36.6		72.4		
-4°	3679.6	1022.1	1.79		24.8	55	72.4		600
	3140.6	872.4	3.44		35.7		82.4		
	2250	625	5.03		42.6		72.4		
-2°	4136.8	1149.1	1.85		28.8	55	72.4		600
	3574.1	992.8	3.38		40		82.4		
	2472.5	686.8	5.26		48.9		72.4		
0°	4453.2	1237	2.02		33.9	75	72.4		600
	3913.9	1087.2	3.5		44.8		83.4		
	2718.7	755.2	5.46		55.9		72.4		
+2°	4757.8	1321.6	2.32	41.5	75	72.4	600		
	4183.6	1162.1	3.74	51.7		82.4			
	2965	823.6	5.62	62.7		72.4			
+4°	5062.3	1406.2	2.6	49.5	160	72.4	600		
	4277.2	1188.1	4.23	60.6		81.4			
	3234.2	898.4	5.62	68.4		72.4			

700QZ-100D

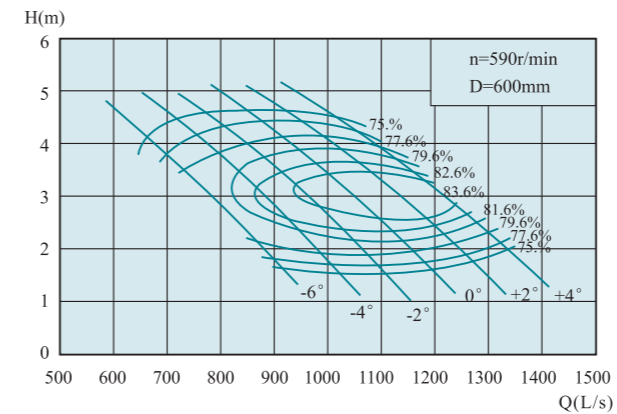

叶片安装角度 Angle	流量Q Capacity		扬程H Head (m)	转速n Speed (r/min)	功率P Power(kw)		效率η Eff. (%)	叶轮直径 Diameter of impeller (mm)	
	(m³/h)	(L/s)			轴功率 Shaft power	电机功率 Motor power			
-6°	3117.2	865.9	2.12	590	22.6	37	79.6	600	
	2929.7	813.8	2.67		26.3		81.2		
	2636.6	732.4	3.51		31.7		79.6		
-4°	3562.6	989.6	1.94		23.7	45	79.6		600
	3281	911.4	2.72		29.4		82.7		
	2865.2	795.9	3.81		37.4		79.6		
-2°	3879	1077.5	1.89		25.1	45	79.6		600
	3574.1	992.8	2.79		32.6		83.3		
	3070.4	852.9	3.99		41.9		79.6		
0°	4183.6	1162.1	1.95		27.9	55	79.6		600
	3867.1	1074.2	2.78		35		83.6		
	3298.7	916.3	4.14		46.8		79.6		
+2°	4453.2	1237	2.1	32	55	79.6	600		
	4101.5	1139.3	2.93	38.9		84.1			
	3562.6	989.6	4.15	50.6		79.6			
+4°	4687.6	1302.1	2.3	36.9	160	79.6	600		
	4394.5	1220.7	2.95	42.2		83.8			
	3925.8	1090.5	3.97	53.4		79.6			

QZ、QH型潜水轴流泵、混流泵性能曲线图与性能参数表 Curve and specification

700QZ-125

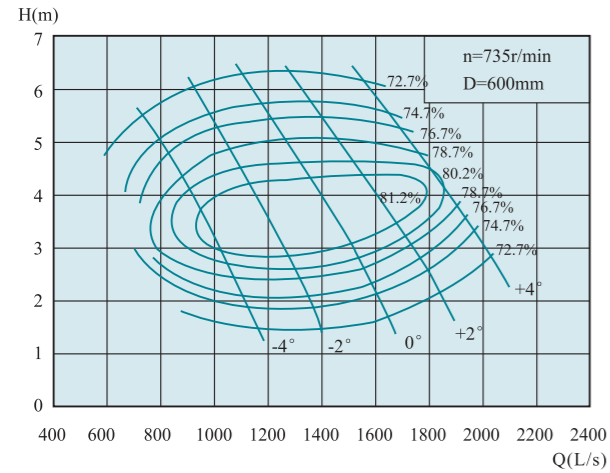

叶片安装角度 Angle	流量Q Capacity		扬程H Head (m)	转速n Speed (r/min)	功率P Power(kw)		效率η Eff. (%)	叶轮直径 Diameter of impeller (mm)
	(m³/h)	(L/s)			轴功率 Shaft power	电机功率 Motor power		
-4°	3970.8	1103	2.1	735	29.6	55	76.7	600
	3620.5	1005.7	3.11		37.8		81.2	
	2890.4	802.9	5.07		53.5		74.7	
-2°	4861.4	1350.4	2.09		36.1	75	76.7	
	4481.6	1244.9	3.23		48.3		81.6	
	3533	981.4	5.49		70.8		74.7	
0°	5737.3	1593.7	2.34		47.7		76.7	
	5284.8	1468	3.56		62.4	110	82.2	
	4248.4	1180.1	5.76		89.3		74.7	
+2°	6379.6	1772.1	2.77		62.8		76.7	
	5868.7	1630.2	3.68		72.1		81.6	
	4919.8	1366.6	5.76		103.4		74.7	
+4°	6963.5	1934.3	3.56	88.1	132	76.7		
	6671.5	1853.2	4.07	91.9		80.5		
	5956.2	1654.5	5.56	120.8		74.7		

700QZ-125D

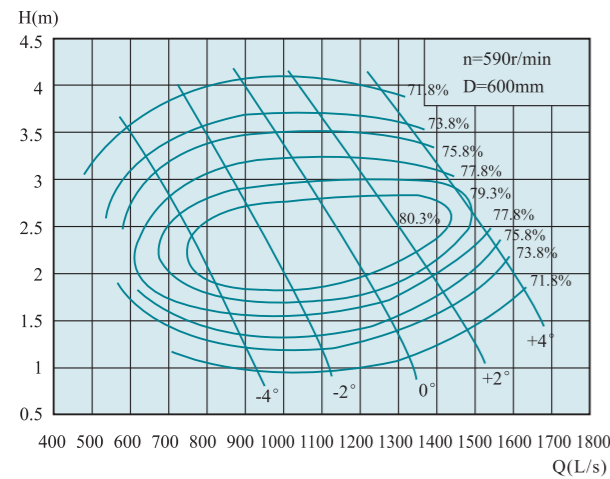

叶片安装角度 Angle	流量Q Capacity		扬程H Head (m)	转速n Speed (r/min)	功率P Power(kw)		效率η Eff. (%)	叶轮直径 Diameter of impeller (mm)
	(m³/h)	(L/s)			轴功率 Shaft power	电机功率 Motor power		
-4°	3187.4	885.4	1.35	735	15.4	30	75.9	600
	2906.3	807.3	2.01		19.8		80.4	
	2320.2	644.5	3.26		27.9		73.9	
-2°	3902.4	1084	1.34		18.8	45	75.9	
	3597.5	999.3	2.08		25.2		80.8	
	2836.1	787.8	3.54		37		73.9	
0°	4605.5	1279.3	1.51		25	55	75.9	
	4242.2	1178.4	2.29		32.5		81.4	
	3410.3	947.3	3.71		46.7		73.9	
+2°	5121	1422.5	1.79		32.9		75.9	
	4711	1308.6	2.37		37.7	75	80.8	
	3949.2	1097	3.71		54		73.9	
+4°	5589.7	1552.7	2.29	46		75.9		
	5355.4	1487.6	2.62	48		79.7		
	4781.2	1328.1	3.58	63.1		73.9		

QZ、QH型潜水轴流泵、混流泵性能曲线图与性能参数表 Curve and specification

700QZ-100C

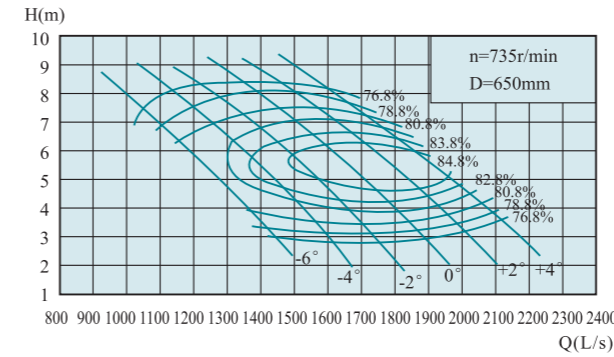

叶片安装角度 Angle	流量Q Capacity		扬程H Head (m)	转速n Speed (r/min)	功率P Power(kw)		效率η Eff. (%)	叶轮直径 Diameter of impeller (mm)
	(m³/h)	(L/s)			轴功率 Shaft power	电机功率 Motor power		
-6°	4937	1371.4	3.86	735	64.3		80.8	650
	4640	1288.9	4.86		74.6	110	82.4	
	4176.4	1160.1	6.39		90		80.8	
-4°	5642.6	1567.4	3.53		67.2		80.8	
	5197	1443.6	4.95		83.6		83.9	
	4538.2	1260.6	6.94		106.2		80.8	
-2°	6143.8	1706.6	3.44		71.3	132	80.8	
	5661	1572.5	5.08		92.7		84.5	
	4862.9	1350.8	7.27		119.2		80.8	
0°	6626.2	1840.6	3.55		79.3		80.8	
	6125	1701.4	5.07		99.8		84.8	
	5225	1451.4	7.54		132.9		80.8	
+2°	7053.1	1959.2	3.82	90.9	160	80.8		
	6496.2	1804.5	5.34	110.8		85.3		
	5642.6	1567.4	7.56	143.9		80.8		
+4°	7424.3	2062.3	4.2	105.2		80.8		
	6960.2	1933.4	5.37	119.8		85		
	6217.9	1727.2	7.24	151.8		80.8		

700QZ-125C

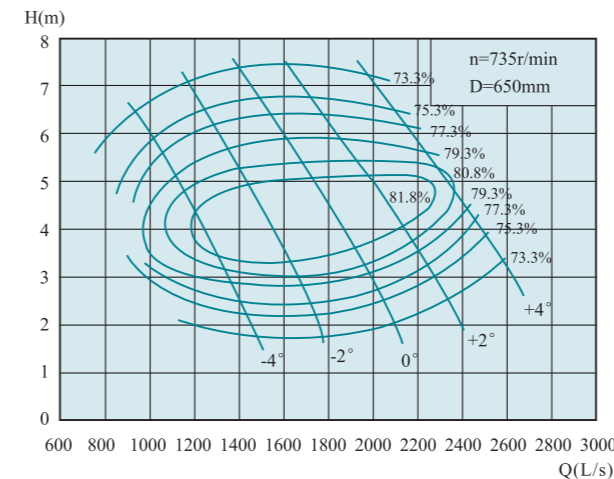

叶片安装角度 Angle	流量Q Capacity		扬程H Head (m)	转速n Speed (r/min)	功率P Power(kw)		效率η Eff. (%)	叶轮直径 Diameter of impeller (mm)
	(m³/h)	(L/s)			轴功率 Shaft power	电机功率 Motor power		
-4°	5048.6	1402.4	2.46	735	43.8	90	77.3	650
	4603	1278.6	3.65		56		81.8	
	3674.9	1020.8	5.95		79.1		75.3	
-2°	6180.8	1716.9	2.45		53.4		77.3	
	5698.1	1582.8	3.79		71.6	110	82.2	
	4491.7	1247.7	6.44		104.7		75.3	
0°	7294.3	2026.2	2.75		70.7		77.3	
	6719	1866.4	4.17		92.2		82.8	
	5401.1	1500.3	6.75		131.9	160	75.3	
+2°	8111.2	2253.1	3.26		93.2		77.3	
	7461.2	2072.6	4.32		106.9		82.2	
	6255	1737.5	6.75		152.8		75.3	
+4°	8853.5	2459.3	4.17	130.1	185	77.3		
	8482.3	2356.2	4.78	136.2		81.1		
	7573	2103.6	6.53	179		75.3		

QZ、QH型潜水轴流泵、混流泵性能曲线图与性能参数表 Curve and specification

700QZ-160

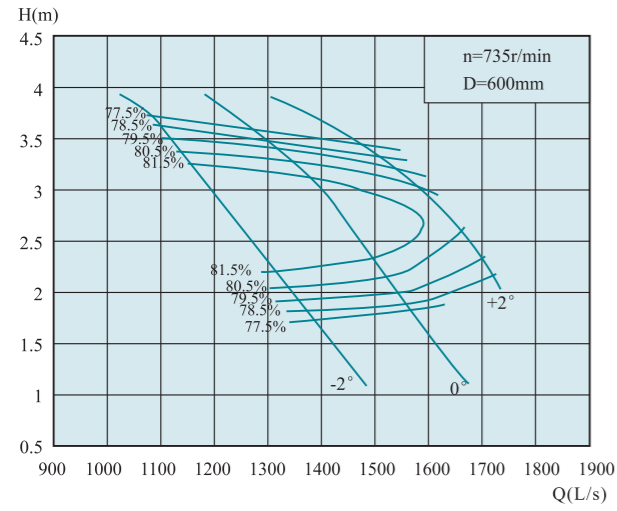

叶片安装角度 Angle	流量Q Capacity		扬程H Head (m)	转速n Speed (r/min)	功率P Power(kw)		效率η Eff. (%)	叶轮直径 Diameter of impeller (mm)		
	(m³/h)	(L/s)			轴功率 Shaft power	电机功率 Motor power				
-2°	4943.5	1373.2	1.81	735	31	55	78.6	600		
	4525.6	1257.1	2.56		38		83.1			
	3963.2	1100.9	3.63		49.9		78.6			
0°	5587.2	1552	1.87		36.2	75	78.6		600	
	5255.6	1459.9	2.57		44.8		82.1			
	4681.4	1300.4	3.47		56.3		78.6			
+2°	6191.3	1719.8	2.16		46.4	75	78.6			600
	5868.7	1630.2	2.77		55		80.6			
	5437.1	1510.3	3.32		62.6		78.6			

700QZ-160C

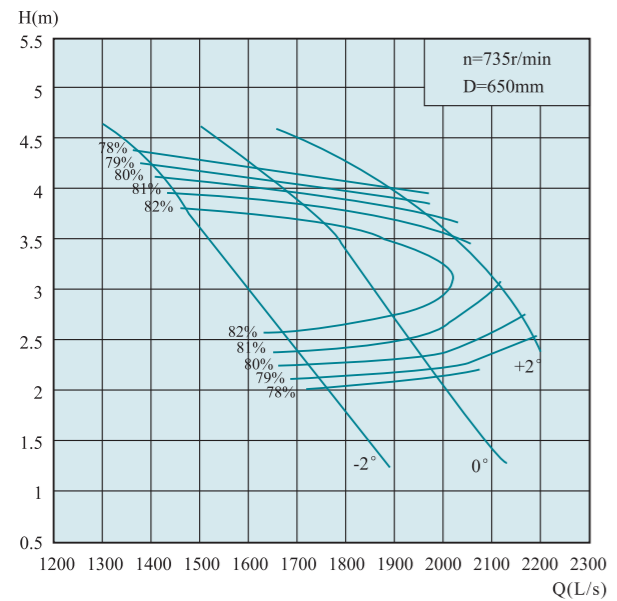

叶片安装角度 Angle	流量Q Capacity		扬程H Head (m)	转速n Speed (r/min)	功率P Power(kw)		效率η Eff. (%)	叶轮直径 Diameter of impeller (mm)		
	(m³/h)	(L/s)			轴功率 Shaft power	电机功率 Motor power				
-2°	6285.6	1746	2.12	735	45.9	90	79.1	650		
	5753.9	1598.3	3		56.3		83.6			
	5038.9	1399.7	4.26		73.9		79.1			
0°	7103.9	1973.3	2.2		53.8	90	79.1		650	
	6682	1856.1	3.02		66.6		82.6			
	5952.2	1653.4	4.08		83.7		79.1			
+2°	7871.8	2186.6	2.53		68.6	110	79.1			650
	7461.4	2072.6	3.26		81.7		81.1			
	6912.7	1920.2	3.9		92.9		79.1			

QZ、QH型潜水轴流泵、混流泵性能曲线图与性能参数表 Curve and specification

700QH-40

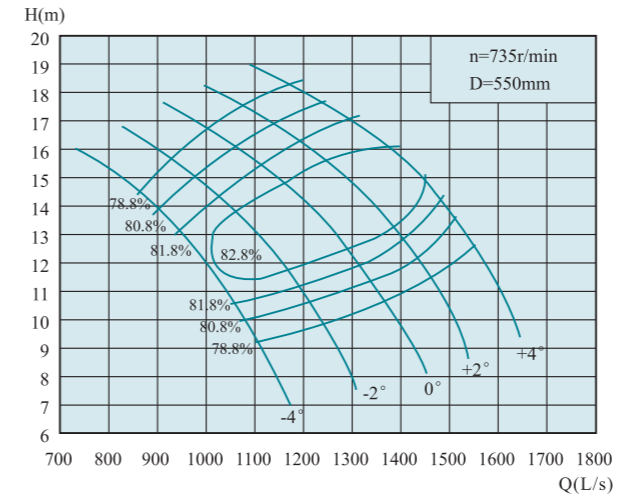

叶片安装角度 Angle	流量Q Capacity		扬程H Head (m)	转速n Speed (r/min)	功率P Power(kw)		效率η Eff. (%)	叶轮直径 Diameter of impeller (mm)				
	(m³/h)	(L/s)			轴功率 Shaft power	电机功率 Motor power						
-4°	3991.7	1108.8	9.18	735	126.7	185	78.8	550				
	3654.4	1015.1	11.79		142.1		82.6					
	3137.4	871.5	14.6		158.4		78.8					
-2°	4475.5	1243.2	9.9		153.2	200	78.8		550			
	4048.2	1124.5	12.78		170.3		82.8					
	3373.6	937.1	15.74		183.6		78.8					
0°	4914	1365	10.68		181.5	220	78.8			550		
	4385.5	1218.2	13.9		199.9		83.1					
	3632	1008.9	16.9		212.3		78.8					
+2°	5273.6	1464.9	11.56		210.8	250	78.8				550	
	4722.8	1311.9	14.68		225.5		83.8					
	3879.4	1077.6	17.75		238.1		78.8					
+4°	5588.6	1552.4	12.74		246.2	280	78.8					550
	5060.2	1405.6	15.72		260.2		83.3					
	4216.7	1171.3	18.46		269.2		78.8					

700QH-40D

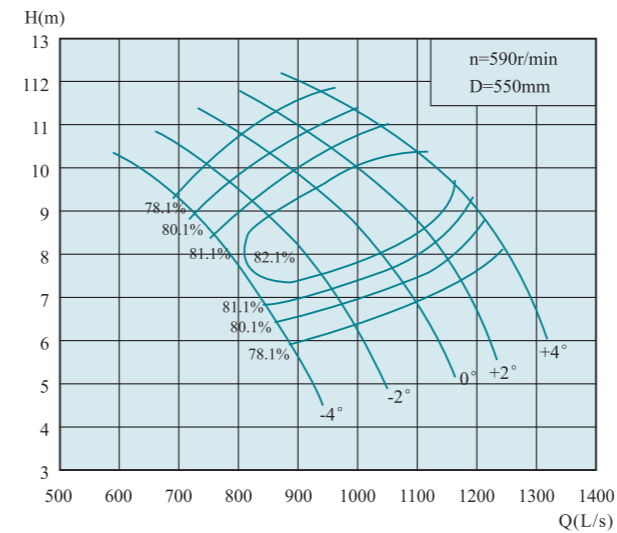

叶片安装角度 Angle	流量Q Capacity		扬程H Head (m)	转速n Speed (r/min)	功率P Power(kw)		效率η Eff. (%)	叶轮直径 Diameter of impeller (mm)				
	(m³/h)	(L/s)			轴功率 Shaft power	电机功率 Motor power						
-4°	3204.4	890.1	5.92	590	66.2	90	78.1	550				
	2933.6	814.9	7.6		74.2		81.9					
	2518.2	699.5	9.4		82.6		78.1					
-2°	3592.4	997.9	6.38		80	110	78.1		550			
	3249.4	902.6	8.24		88.9		82.1					
	2707.9	752.2	10.14		95.8		78.1					
0°	3944.5	1095.7	6.88		94.7	132	78.1			550		
	3520.4	977.9	8.96		104.3		82.4					
	2915.6	809.9	10.89		110.8		78.1					
+2°	4233.2	1175.9	7.45		110	132	78.1				550	
	3791.2	1053.1	9.46		117.6		83.1					
	3114	865	11.44		124.3		78.1					
+4°	4486	1246.1	8.21		128.5	160	78.1					550
	4061.9	1128.3	10.13		135.7		82.6					
	3384.7	940.2	11.9		140.5		78.1					

QZ、QH型潜水轴流泵、混流泵性能曲线图与性能参数表 Curve and specification

700QH-50

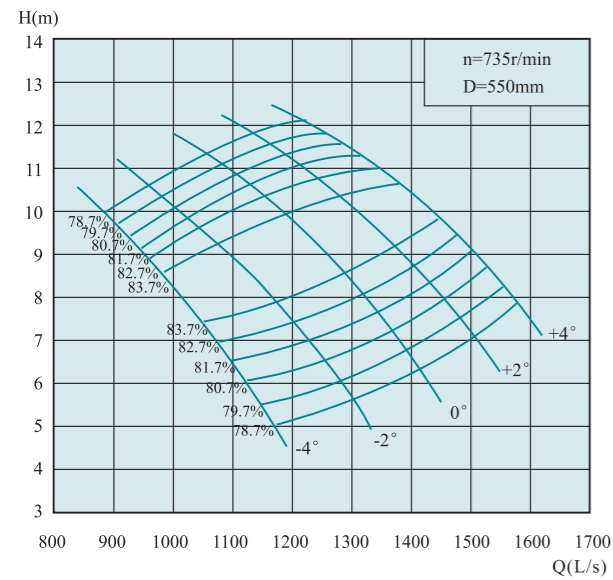

叶片安装角度 Angle	流量Q Capacity		扬程H Head (m)	转速n Speed (r/min)	功率P Power(kw)		效率η Eff. (%)	叶轮直径 Diameter of impeller (mm)
	(m³/h)	(L/s)			轴功率 Shaft power	电机功率 Motor power		
-4°	4149.4	1152.6	5.48	735	77.6	110	79.8	550
	3598.2	999.5	8.38		98.1		83.8	
	3249.7	902.7	9.72		107.9		79.8	
-2°	4610.2	1280.6	6.05		95.2	132	79.8	
	3935.5	1093.2	9.07		115.9	132	83.9	
	3530.9	980.8	10.36		124.9		79.8	
0°	5026.3	1396.2	6.74		115.7	160	79.8	
	4385.5	1218.2	9.5		135.5	160	83.8	
	3890.5	1080.7	11.1		147.5		79.8	
+2°	5341.3	1483.7	7.51		137	185	79.8	
	4610.2	1280.6	10.36		155.3	185	83.8	
	4227.8	1174.4	11.57		167		79.8	
+4°	5599.8	1555.5	8.2		156.8	200	79.8	
	4947.5	1374.3	10.71		172.3	200	83.8	
	4520.5	1255.7	11.83		182.6		79.8	

700QH-50D

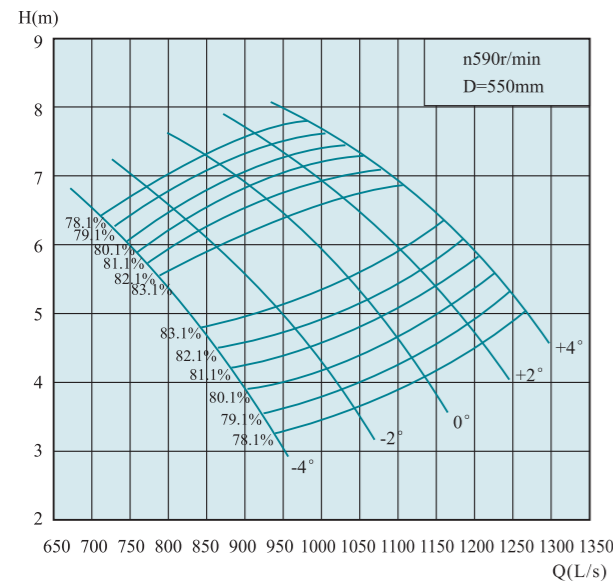

叶片安装角度 Angle	流量Q Capacity		扬程H Head (m)	转速n Speed (r/min)	功率P Power(kw)		效率η Eff. (%)	叶轮直径 Diameter of impeller (mm)
	(m³/h)	(L/s)			轴功率 Shaft power	电机功率 Motor power		
-4°	3330.7	925.2	3.53	590	40.5	75	79.1	550
	2888.3	802.3	5.4		51.1		83.1	
	2608.6	724.6	6.26		56.3		79.1	
-2°	3700.8	1028	3.9		49.7	75	79.1	
	3159.4	877.6	5.84		60.4	75	83.2	
	2834.3	787.3	6.68		65.2		79.1	
0°	4034.9	1120.8	4.34		60.3	90	79.1	
	3520.4	977.9	6.12		70.7	90	83.1	
	3123	867.5	7.15		76.9		79.1	
+2°	4287.6	1191	4.84		71.5	90	79.1	
	3700.8	1028	6.68		81.1	90	83.1	
	3393.7	942.7	7.46		87.2		79.1	
+4°	4495	1248.6	5.29		81.9	110	79.1	
	3971.5	1103.2	6.9		89.9	110	83.1	
	3628.4	1007.9	7.62		95.2		79.1	

外形安装尺寸图 Outline installation dimension drawing

700QZ-50, 700QZ-70, 700QZ-85, 700QZ-100, 700QZ-125, 700QZ-160, 700QZ-50D, 700QZ-70D, 700QZ-85D, 700QZ-100D, 700QZ-125D, 700QZ-100C, 700QZ-125C, 700QZ-160C, 700QH-40, 700QH-40D, 700QH-50, 700QH-50D

1、井筒悬吊式安装
Suspension installation of wellbore

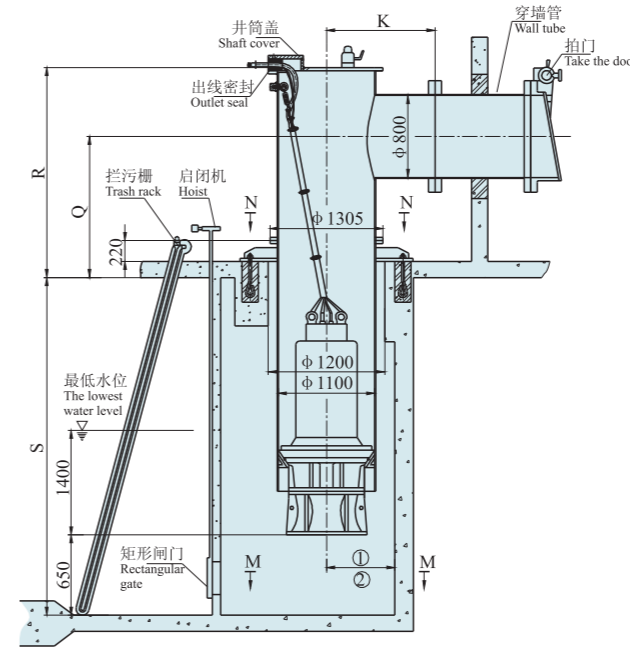

2、混凝土预制井筒式安装
Precast concrete shaft installation

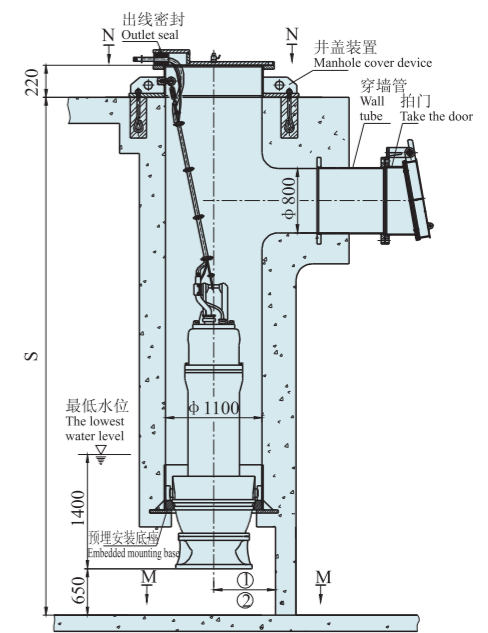

3、弯管悬吊式安装
Bend suspension installation

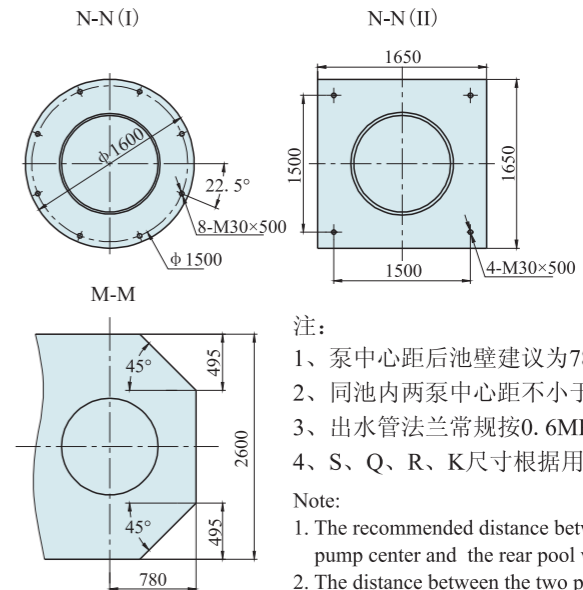
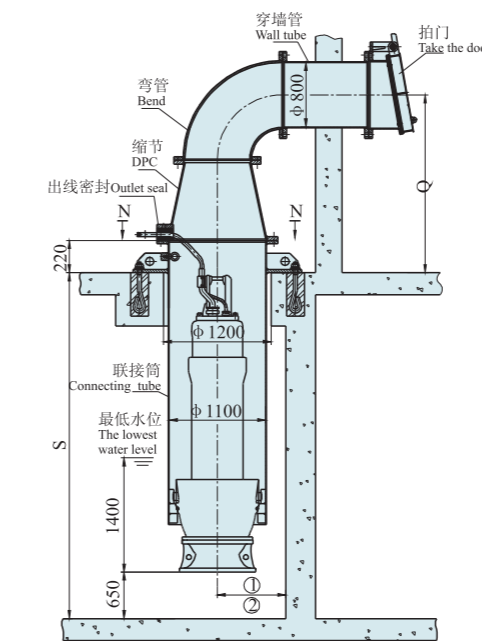

注：
1、泵中心距后池壁建议为780；
2、同池内两泵中心距不小于2600；
3、出水管法兰常规按0.6MPa；
4、S、Q、R、K尺寸根据用户要求。

Note:
1. The recommended distance between the pump center and the rear pool wall is 780;
2. The distance between the two pump centers in the same pool shall not be less than 2600;
3. The outlet pipe flange is normally 0.6mpa;
4. Sizes of S, Q, R and K are according to user requirements.

QZ、QH型潜水轴流泵、混流泵性能曲线图与性能参数表 Curve and specification

700QZ-70C

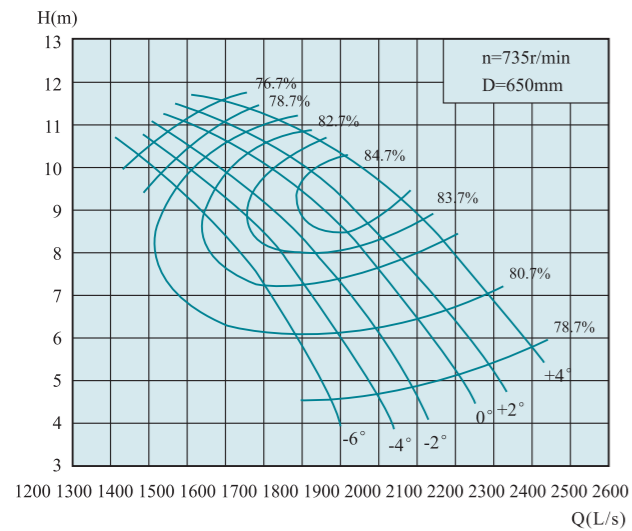

叶片安装角度 Angle	流量Q Capacity		扬程H Head (m)	转速n Speed (r/min)	功率P Power(kw)		效率η Eff. (%)	叶轮直径 Diameter of impeller (mm)	
	(m³/h)	(L/s)			轴功率 Shaft power	电机功率 Motor power			
-6°	6682	1856.1	4.52	735	104.6	185	78.7	650	
	5939.6	1649.9	7.96		155.8		82.7		
	4918.7	1366.3	10.25		179.1		76.7		
-4°	7146	1985	4.64		114.8	200	78.7		650
	6088	1691.1	8.44		166.9		83.9		
	5104.1	1417.8	10.71		194.2		76.7		
-2°	7517.2	2088.1	4.82		125.5	220	78.7		650
	6403.3	1778.7	8.81		182.8		84.1		
	5215.7	1448.8	10.86		201.2		76.7		
0°	7888.3	2191.2	5.19		141.8	250	78.7		650
	6663.2	1850.9	9.19		195.9		85.2		
	5345.6	1484.9	11.22		213.1		76.7		
+2°	8166.6	2268.5	5.43	153.5	250	78.7	650		
	6830.3	1897.3	9.29	202		85.6			
	5401.1	1500.3	11.34	217.6		76.7			
+4°	8575.2	2382	5.91	175.5	250	78.7	650		
	7090.2	1969.5	9.89	225.6		84.7			
	5735.2	1593.1	11.58	236		76.7			

700QZ-85C

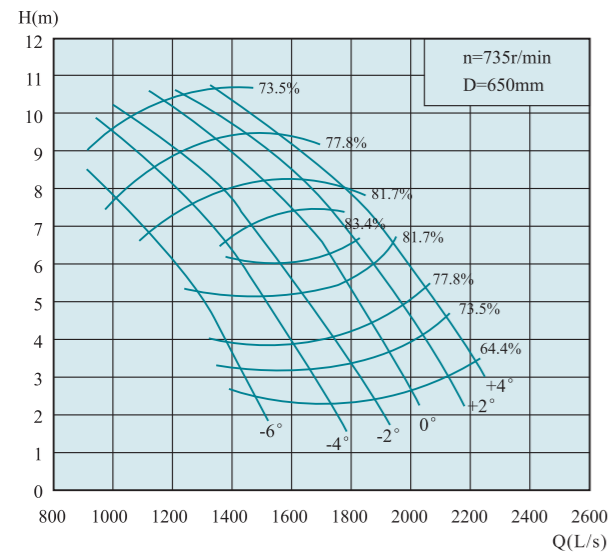

叶片安装角度 Angle	流量Q Capacity		扬程H Head (m)	转速n Speed (r/min)	功率P Power(kw)		效率η Eff. (%)	叶轮直径 Diameter of impeller (mm)	
	(m³/h)	(L/s)			轴功率 Shaft power	电机功率 Motor power			
-6°	5029.9	1397.2	3.37	735	62.8	110	78.7	650	
	4603	1278.6	5.11		77.6		82.7		
	3248.3	902.3	8.62		103.7		76.7		
-4°	5828	1618.9	3.26		70.3	132	78.7		650
	4974.5	1381.8	6.27		101.7		83.9		
	3563.6	989.9	9.16		120.9		76.7		
-2°	6552	1820	3.37		81.8	160	78.7		650
	5661	1572.5	6.15		113.5		84.1		
	3916.4	1087.9	9.59		139.1		76.7		
0°	7053.1	1959.2	3.68		96.1	185	78.7		650
	6199.2	1722	6.38		127.4		85.2		
	4306	1196.1	9.95		158.6		76.7		
+2°	7535.9	2093.3	4.22	117.7	185	78.7	650		
	6626.2	1840.6	6.82	147.3		85.6			
	4695.8	1304.4	10.24	178		76.7			
+4°	8018.3	2227.3	4.74	140.7	200	78.7	650		
	6774.8	1881.9	7.71	172.3		84.7			
	5122.8	1423	10.23	194		76.7			

QZ、QH型潜水轴流泵、混流泵性能曲线图与性能参数表 Curve and specification

800QZ-50

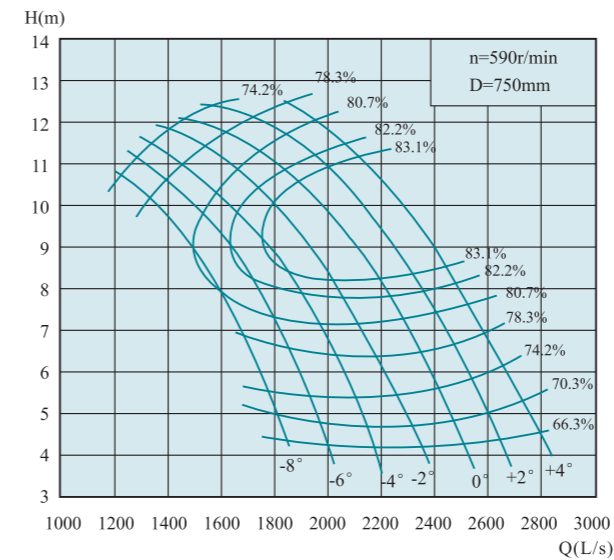

叶片安装角度 Angle	流量Q Capacity		扬程H Head (m)	转速n Speed (r/min)	功率P Power(kw)		效率η Eff. (%)	叶轮直径 Diameter of impeller (mm)	
	(m³/h)	(L/s)			轴功率 Shaft power	电机功率 Motor power			
-6°	6997.7	1943.8	4.83	590	130.8	200	70.4	750	
	5904.7	1640.2	8.83		172		82.6		
	4675	1298.6	11.12		188.1		75.3		
-4°	7599.2	2110.9	4.74		139.4	220	70.4		750
	6419.9	1783.3	9.1		190		83.8		
	4824	1340	11.64		203.2		75.3		
-2°	8203.7	2278.8	4.74		150.5	250	70.4		750
	6613.6	1837.1	9.37		201.5		83.8		
	5062.3	1406.2	11.96		219.1		75.3		
0°	8858.9	2460.8	4.97		170.4	250	70.4		750
	7346.2	2040.6	9.41		224.3		84		
	5866.2	1629.5	11.8		240.6		78.4		
+2°	9394.9	2609.7	5.08	184.7	280	70.4	750		
	7733.2	2148.1	9.65	242.7		83.8			
	6313	1753.6	12.19	267.5		78.4			
+4°	9752	2708.9	5.51	208	315	70.4	750		
	8132	2258.9	9.92	262.3		83.8			
	6610.7	1836.3	12.42	285.4		78.4			

800QZ-70

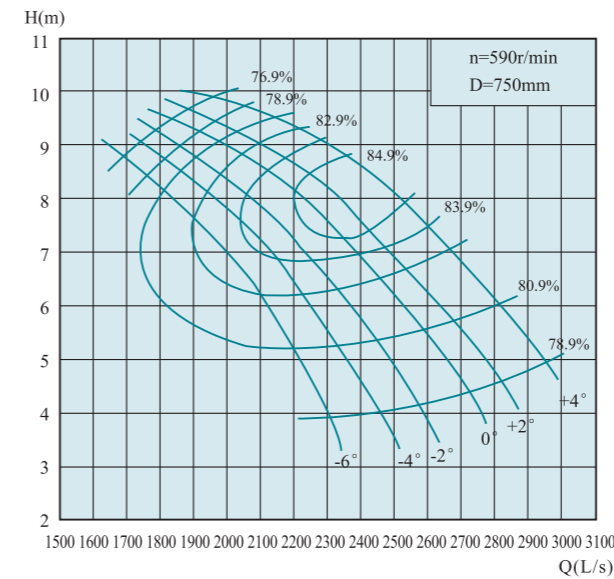

叶片安装角度 Angle	流量Q Capacity		扬程H Head (m)	转速n Speed (r/min)	功率P Power(kw)		效率η Eff. (%)	叶轮直径 Diameter of impeller (mm)	
	(m³/h)	(L/s)			轴功率 Shaft power	电机功率 Motor power			
-6°	8239.7	2288.8	3.88	590	110.4	200	78.9	750	
	7324.2	2034.5	6.83		164.4		82.9		
	6065.3	1684.8	8.8		189.1		76.9		
-4°	8811.7	2447.7	3.98		121.1	220	78.9		750
	7507.1	2085.3	7.24		176.1		84.1		
	6294.2	1748.4	9.19		205		76.9		
-2°	9269.6	2574.9	4.14		13205	250	78.9		750
	7896.2	2193.4	7.55		192.7		84.3		
	6431.4	1786.5	9.31		212.2		76.9		
0°	9727.2	2702	4.45		149.5	250	78.9		750
	8216.6	2282.4	7.89		206.9		85.4		
	6591.6	1831	9.62		224.7		76.9		
+2°	10070.6	2797.4	4.66	162.1	280	78.9	750		
	8422.9	2339.7	7.97	213.2		85.8			
	6660.4	1850.1	9.73	229.6		76.9			
+4°	10574.3	2937.3	5.07	185.2	280	78.9	750		
	8743.3	2428.7	8.49	238.3		84.9			
	7072.2	1964.5	9.93	248.9		76.9			

QZ、QH型潜水轴流泵、混流泵性能曲线图与性能参数表 Curve and specification

800QZ-85

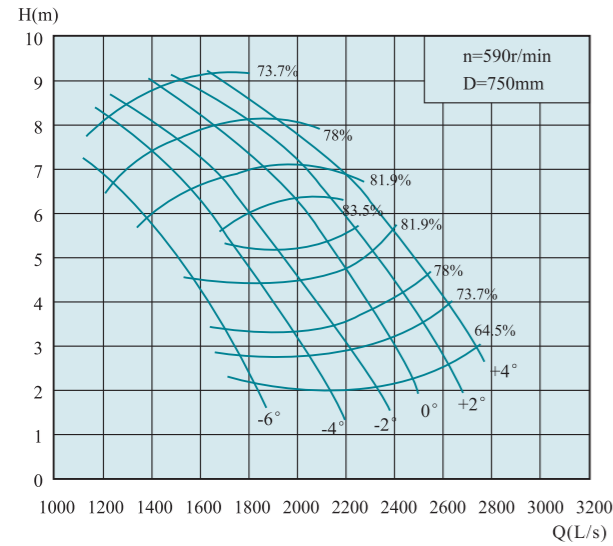

叶片安装角度 Angle	流量Q Capacity		扬程H Head (m)	转速n Speed (r/min)	功率P Power(kw)		效率η Eff. (%)	叶轮直径 Diameter of impeller (mm)
	(m³/h)	(L/s)			轴功率 Shaft power	电机功率 Motor power		
-6°	6202.8	1723	2.89	590	66.2	132	73.8	750
	5676.1	1576.7	4.39		82	109.4	82.8	
	4005.4	1112.6	7.4		109.4	132	73.8	
-4°	7186.7	1996.3	2.79		74	132	73.8	
	6134	1703.9	5.38		107.3	132	83.8	
	4394.5	1220.7	7.85		127.4	132	73.8	
-2°	8079.5	2244.3	2.89		86.2	160	73.8	
	6980.8	1939.1	5.28		119.9	160	83.8	
	4829.4	1341.5	8.23		146.8	160	73.8	
0°	8697.2	2415.9	3.16		101.5	185	73.8	
	7644.6	2123.5	5.47		134.4	185	84.8	
	5310	1475	8.54		167.4	185	73.8	
+2°	9292.7	2581.3	3.62	124.2	200	73.8		
	8170.9	2269.7	5.85	155.4	200	83.8		
	5790.6	1608.5	8.79	187.9	200	73.8		
+4°	9887.8	2746.6	4.07	148.6	220	73.8		
	8354.2	2320.6	6.61	181.7	220	82.8		
	6316.9	1754.7	8.77	204.6	220	73.8		

800QZ-100

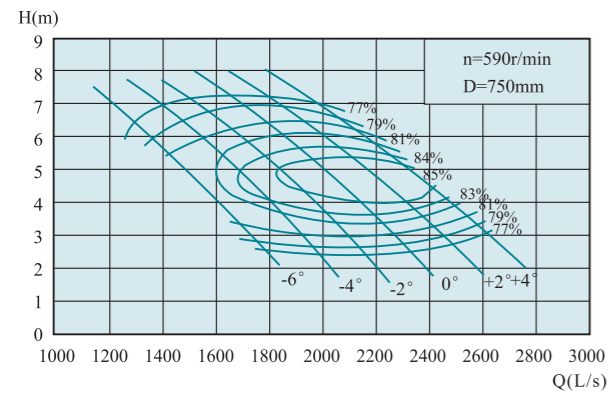

叶片安装角度 Angle	流量Q Capacity		扬程H Head (m)	转速n Speed (r/min)	功率P Power(kw)		效率η Eff. (%)	叶轮直径 Diameter of impeller (mm)
	(m³/h)	(L/s)			轴功率 Shaft power	电机功率 Motor power		
-6°	6088.3	1691.2	3.31	590	67.8	110	81	750
	5721.8	1589.4	4.17		78.7	110	82.6	
	5149.8	1430.5	5.48		94.9	110	81	
-4°	6958.1	1932.8	3.03		70.9	132	81	
	6408.7	1780.2	4.24		88	132	84.1	
	5596.2	1554.5	5.95		112	132	81	
-2°	7575.8	2104.4	2.95		75.2	160	81	
	6980.8	1939.1	4.36		97.9	160	84.7	
	5996.5	1665.7	6.24		125.9	160	81	
0°	8170.9	2269.7	6.04		83.6	160	81	
	7553.2	2098.1	4.35		105.3	160	85	
	6442.9	1789.7	6.47		140.2	160	81	
+2°	8697.2	2415.9	3.28	96	185	81		
	8010.7	2225.2	4.58	116.9	185	85.5		
	6958.1	1932.8	6.49	151.9	185	81		
+4°	9155.2	2543.1	3.6	110.9	185	81		
	8583.1	2384.2	4.6	126.3	185	85.2		
	7667.3	2129.8	6.21	160.2	185	81		

QZ、QH型潜水轴流泵、混流泵性能曲线图与性能参数表 Curve and specification

800QZ-125

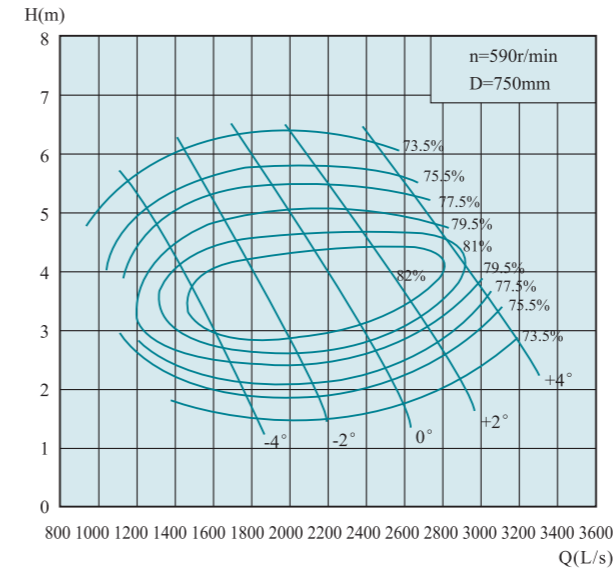

叶片安装角度 Angle	流量Q Capacity		扬程H Head (m)	转速n Speed (r/min)	功率P Power(kw)		效率η Eff. (%)	叶轮直径 Diameter of impeller (mm)
	(m³/h)	(L/s)			轴功率 Shaft power	电机功率 Motor power		
-4°	6225.5	1729.3	2.11	590	46.2	90	77.5	750
	5676.1	1576.7	3.14		59.2	90	82	
	4531.7	1258.8	5.1		83.4	90	75.5	
-2°	7621.6	2117.1	2.1		56.3	132	77.5	
	7026.5	1951.8	3.25		75.5	132	82.4	
	5539	1538.6	5.53		110.6	132	75.5	
0°	8995	2498.6	2.36		74.6	160	77.5	
	8285.4	2301.5	3.58		97.4	160	83	
	6660.4	1850.1	5.79		139.2	160	75.5	
+2°	10001.9	2778.3	2.79		98.1	185	77.5	
	9200.9	2555.8	3.7		112.6	185	82.4	
	7713.4	2142.6	5.79		161.2	185	75.5	
+4°	10917.7	3032.7	3.58	137.4	200	77.5		
	10459.8	2905.5	4.1	143.7	200	81.3		
	9338.4	2594	5.6	188.7	200	75.5		

800QZ-160

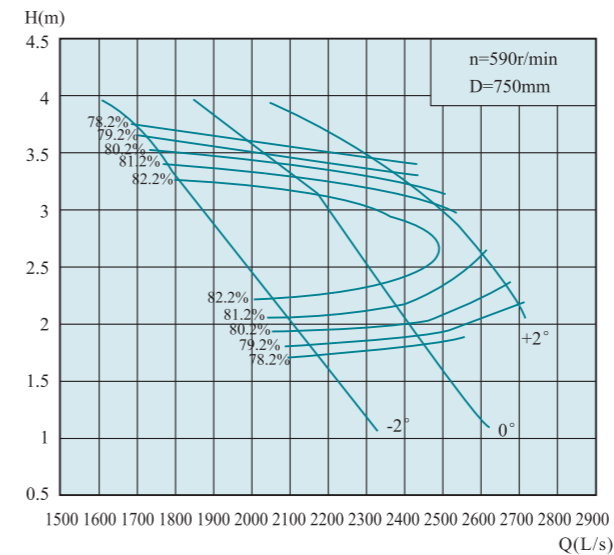

叶片安装角度 Angle	流量Q Capacity		扬程H Head (m)	转速n Speed (r/min)	功率P Power(kw)		效率η Eff. (%)	叶轮直径 Diameter of impeller (mm)
	(m³/h)	(L/s)			轴功率 Shaft power	电机功率 Motor power		
-2°	7750.8	2153	1.82	590	48.5	90	79.3	750
	7095.2	1970.9	2.58		59.5	90	83.8	
	6213.6	1726	3.65		77.9	90	79.3	
0°	8759.9	2433.3	1.88		56.6	160	79.3	
	8239.7	2288.8	2.59		70.2	160	82.8	
	7339.7	2038.8	3.5		88.3	160	79.3	
+2°	9707	2696.4	2.17		72.4	185	79.3	
	9200.9	2555.8	2.79		86	185	81.3	
	8524.1	2367.8	3.34		97.8	185	79.3	

QZ、QH型潜水轴流泵、混流泵性能曲线图与性能参数表 Curve and specification

800QH-40

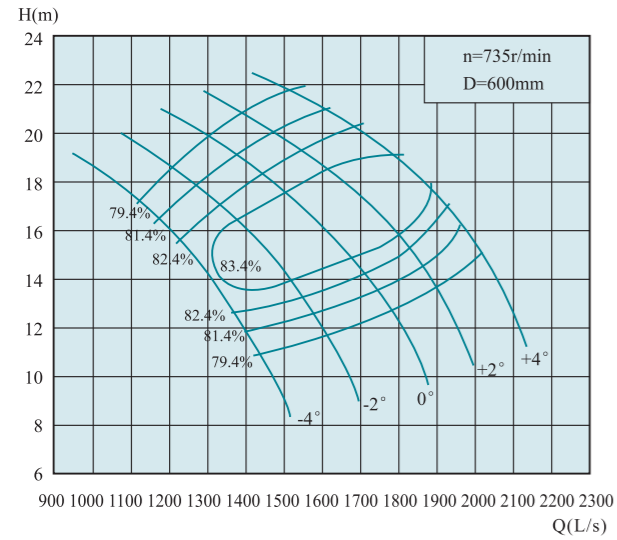

叶片安装角度 Angle	流量Q Capacity		扬程H Head (m)	转速n Speed (r/min)	功率P Power(kw)		效率η Eff. (%)	叶轮直径 Diameter of impeller (mm)
	(m³/h)	(L/s)			轴功率 Shaft power	电机功率 Motor power		
-4°	5182.6	1439.6	10.93	735	194.4	250	79.4	600
	4744.4	1317.9	14.03		218	250	83.2	
	4073	1131.4	17.37		242.8	250	79.4	
-2°	5810.4	1614	11.78		234.9	315	79.4	
	5255.6	1459.9	15.21		261.2	315	83.4	
	4379.8	1216.6	18.74		281.7	315	79.4	
0°	6379.6	1772.1	12.71		278.3	355	79.4	
	5693.4	1581.5	16.55		306.9	355	83.7	
	4715.3	1309.8	20.11		325.4	355	79.4	
+2°	6846.8	1901.9	13.75		323.1	400	79.4	
	6131.5	1703.2	17.47		345.8	400	84.4	
	5036.4	1399	21.12		365.1	400	79.4	
+4°	7255.4	2015.4	15.16		377.5	450	79.4	
	6569.3	1824.8	18.71		399.2	450	83.9	
	5474.5	1520.7	21.97		412.8	450	79.4	

QZ、QH型潜水轴流泵、混流泵性能曲线图与性能参数表 Curve and specification

800QH-50

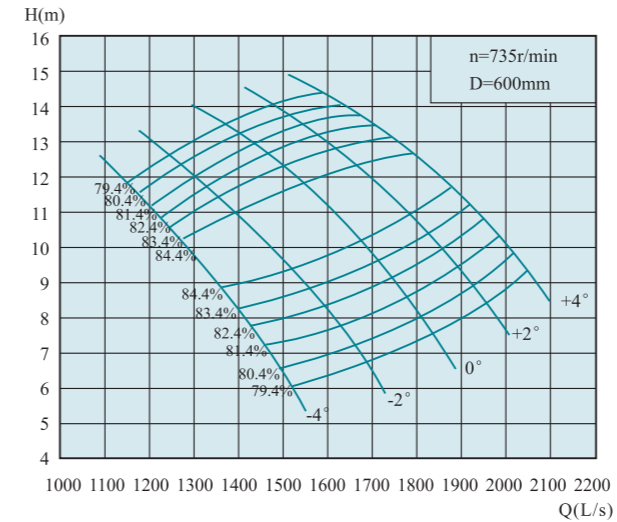

叶片安装角度 Angle	流量Q Capacity		扬程H Head (m)	转速n Speed (r/min)	功率P Power(kw)		效率η Eff. (%)	叶轮直径 Diameter of impeller (mm)
	(m³/h)	(L/s)			轴功率 Shaft power	电机功率 Motor power		
-4°	5387	1496.4	6.53	735	119.2	185	80.4	600
	4671.7	1297.7	9.97		150.4	185	84.4	
	4218.8	1171.9	11.56		165.3	185	80.4	
-2°	5985.4	1662.6	7.19		145.9	200	80.4	
	5109.5	1419.3	10.79		177.8	200	84.5	
	4583.9	1273.3	12.33		191.6	200	80.4	
0°	6525.7	1812.7	8.02		177.4	250	80.4	
	5693.4	1581.5	11.31		207.9	250	84.4	
	5051.2	1403.1	13.21		226.2	250	80.4	
+2°	6934.3	1926.2	8.94		210.1	280	80.4	
	5985.4	1662.6	12.33		238.3	280	84.4	
	5488.9	1524.7	13.77		256.2	280	80.4	
+4°	7270.2	2019.5	9.76		240.5	315	80.4	
	6423.5	1784.3	12.74		264.2	315	84.4	
	5868.7	1630.2	14.08		280.1	315	80.4	

800QH-40D

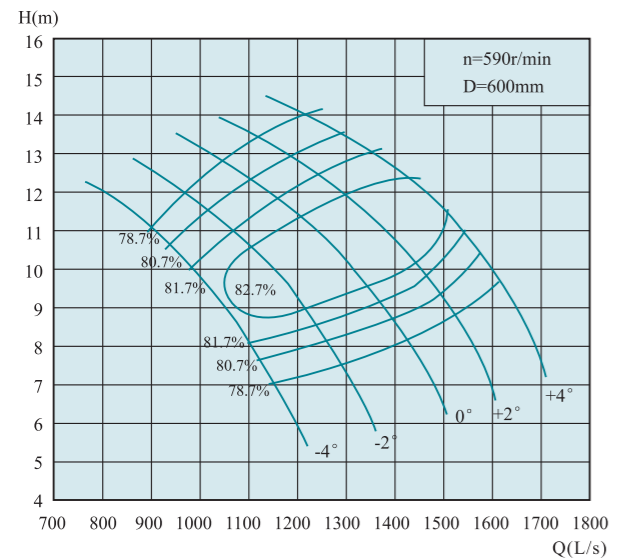

叶片安装角度 Angle	流量Q Capacity		扬程H Head (m)	转速n Speed (r/min)	功率P Power(kw)		效率η Eff. (%)	叶轮直径 Diameter of impeller (mm)
	(m³/h)	(L/s)			轴功率 Shaft power	电机功率 Motor power		
-4°	4160.2	1155.6	7.04	590	101.4	132	78.7	600
	3808.4	1057.9	9.04		113.7	132	82.5	
	3269.5	908.2	11.19		126.7	132	78.7	
-2°	4664.2	1295.6	7.59		122.6	160	78.7	
	4218.8	1171.9	9.8		136.2	160	82.7	
	3515.8	976.6	12.07		146.9	160	78.7	
0°	5121	1422.5	8.19		145.2	185	78.7	
	4570.2	1269.5	10.66		159.9	185	83	
	3785	1051.4	12.96		169.9	185	78.7	
+2°	5496.1	1526.7	8.86		168.6	200	78.7	
	4921.9	1367.2	11.26		180.4	200	83.7	
	4042.8	1123	13.61		190.5	200	78.7	
+4°	5824.1	1617.8	9.77		197	220	78.7	
	5273.3	1464.8	12.05		208.1	220	83.2	
	4394.5	1220.7	14.16		215.5	220	78.7	

800QH-50D

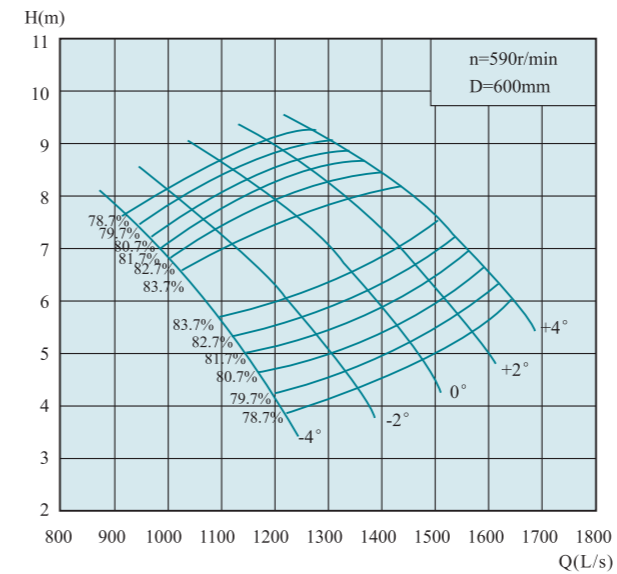

叶片安装角度 Angle	流量Q Capacity		扬程H Head (m)	转速n Speed (r/min)	功率P Power(kw)		效率η Eff. (%)	叶轮直径 Diameter of impeller (mm)
	(m³/h)	(L/s)			轴功率 Shaft power	电机功率 Motor power		
-4°	4324.3	1201.2	4.21	590	62.2	90	79.7	600
	3750.1	1041.7	6.42		78.4	90	83.7	
	3386.5	940.7	7.45		86.3	90	79.7	
-2°	4804.6	1334.6	4.64		76.2	110	79.7	
	4101.5	1139.3	6.95		92.7	110	83.8	
	3679.6	1022.1	7.95		100	110	79.7	
0°	5238.4	1455.1	5.17		92.6	132	79.7	
	4570.2	1269.5	7.28		108.3	132	83.7	
	4054.7	1126.3	8.51		118	132	79.7	
+2°	5566.3	1546.2	5.76		109.6	160	79.7	
	4804.6	1334.6	7.95		124.4	160	83.7	
	4406	1223.9	8.87		133.6	160	79.7	
+4°	5836	1621.1	6.29		125.5	160	79.7	
	5156.3	1432.3	8.21		137.8	160	83.7	
	4711	1308.6	9.07		146.1	160	79.7	

外形安装尺寸图 Outline installation dimension drawing

800QZ-50, 800QZ-70, 800QZ-85, 800QZ-100, 800QZ-125, 800QZ-160
700QZ-70C, 700QZ-85C, 800QH-40, 800QH-40D, 800QH-50, 800QH-50D

1、井筒悬吊式安装
Suspension installation of wellbore

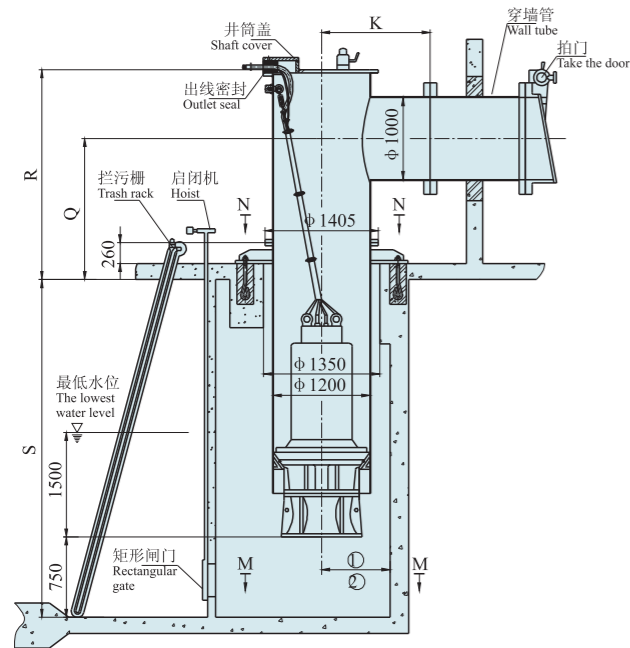

2、混凝土预制井筒式安装
Precast concrete shaft installation

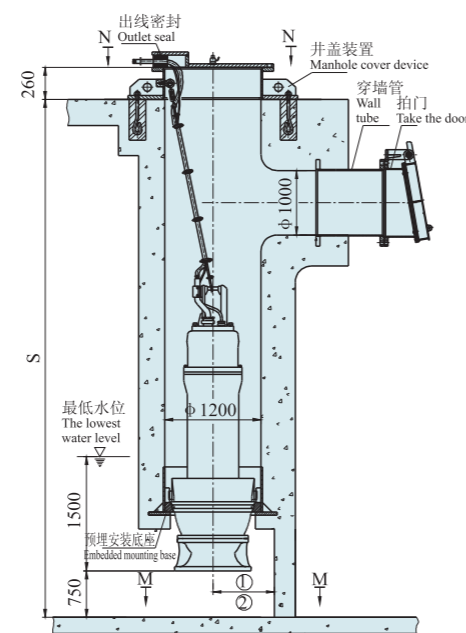

3、弯管悬吊式安装
Bend suspension installation

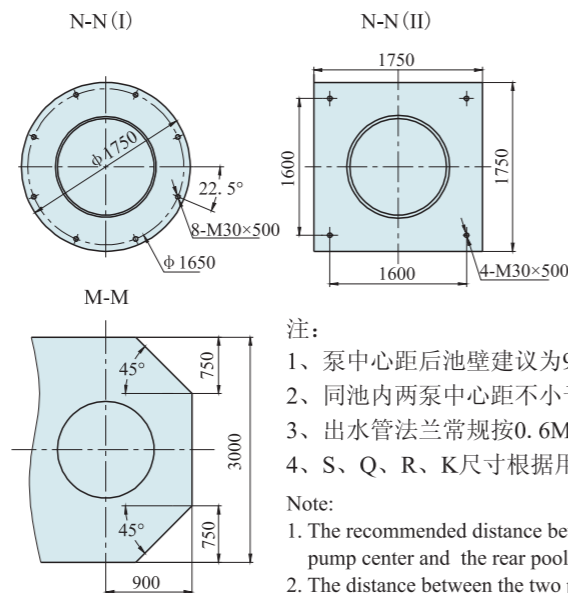
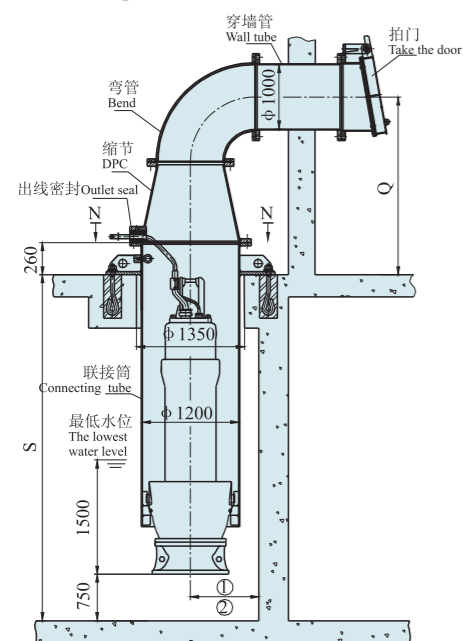

- 注:
- 1、泵中心距后池壁建议为900;
 - 2、同池内两泵中心距不小于3000;
 - 3、出水管法兰常规按0.6MPa;
 - 4、S、Q、R、K尺寸根据用户要求。

- Note:
1. The recommended distance between the pump center and the rear pool wall is 900;
 2. The distance between the two pump centers in the same pool shall not be less than 3000;
 3. The outlet pipe flange is normally 0.6mpa;
 4. Sizes of S, Q, R and K are according to user requirements.

QZ、QH型潜水轴流泵、混流泵性能曲线图与性能参数表 Curve and specification

900QZ-50

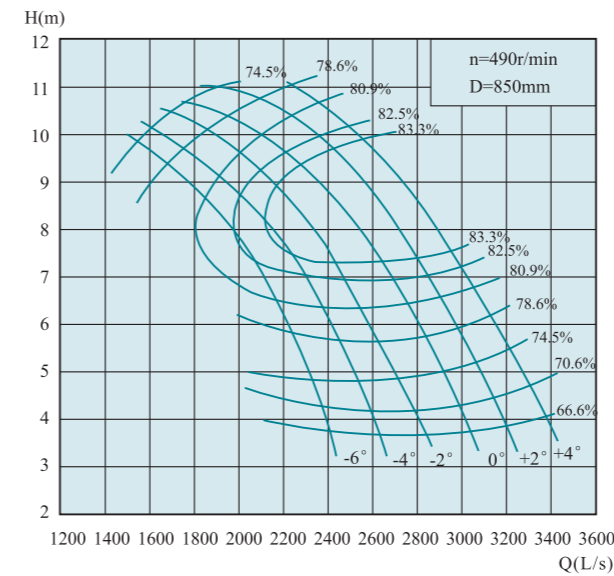

叶片安装角度 Angle	流量Q Capacity		扬程H Head (m)	转速n Speed (r/min)	功率P Power(kw)		效率η Eff. (%)	叶轮直径 Diameter of impeller (mm)
	(m³/h)	(L/s)			轴功率 Shaft power	电机功率 Motor power		
-6°	8460	2350	4.28	490	139.8	220	70.6	850
	7138.8	1983	7.82		183.7		82.8	
	5652	1570	9.85		200.9		75.5	
-4°	9187.2	2552	4.2		148.9	250	70.6	
	7761.6	2156	8.06		202.9		84	
	5832	1620	10.31		217		75.5	
-2°	9918	2755	4.2		160.8	280	70.6	
	7995.6	2221	8.3		215.3		84	
	6120	1700	10.6		234.1		75.5	
0°	10710	2975	4.4		181.9	315	70.6	
	8881.2	2467	8.34		239.7		84.2	
	7092	1970	10.45		256.9		78.6	
+2°	11358	3155	4.5	197.3	315	70.6		
	9349.2	2597	8.55	259.3		84		
	7632	2120	10.8	285.8		78.6		
+4°	11790	3275	4.88	222.1	315	70.6		
	9831.6	2731	8.79	280.3		84		
	7992	2220	11	304.8		78.6		

900QZ-70

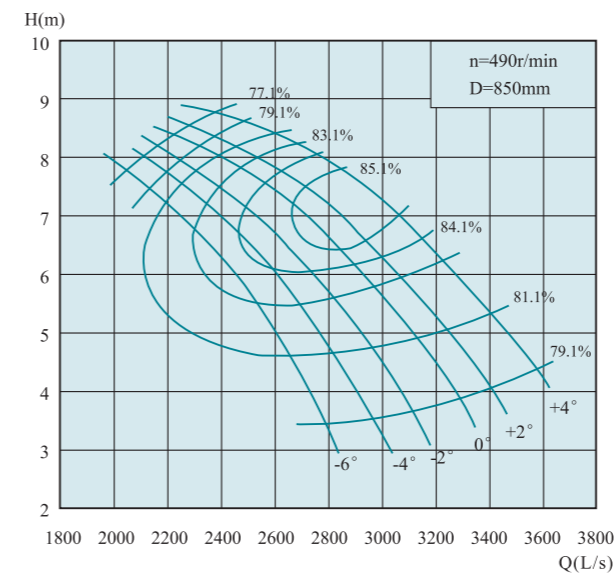

叶片安装角度 Angle	流量Q Capacity		扬程H Head (m)	转速n Speed (r/min)	功率P Power(kw)		效率η Eff. (%)	叶轮直径 Diameter of impeller (mm)
	(m³/h)	(L/s)			轴功率 Shaft power	电机功率 Motor power		
-6°	9961.6	2767.1	3.44	490	118.1	220	79.1	850
	8854.6	2459.6	6.05		175.7		83.1	
	7332.8	2036.9	7.79		201.9		77.1	
-4°	10653.5	2959.3	3.53		129.6	250	79.1	
	9076	2521.1	6.42		188.4		84.3	
	7609.7	2113.8	8.14		218.9		77.1	
-2°	11206.8	3113	3.67		141.7	280	79.1	
	9546.5	2651.8	6.69		206		84.5	
	7775.6	2159.9	8.25		226.7		77.1	
0°	11760.1	3266.7	3.94		159.6	280	79.1	
	9933.8	2759.4	6.99		221		85.6	
	7969.3	2213.7	8.53		240.3		77.1	
+2°	12175.2	3382	4.13	173.2	280	79.1		
	10183	2828.6	7.06	227.8		86		
	8052.1	2236.7	8.62	245.3		77.1		
+4°	12784	3551.1	4.49	197.7	280	79.1		
	10570.3	2936.2	7.52	254.5		85.1		
	8550.4	2375.1	8.8	265.9		77.1		

QZ、QH型潜水轴流泵、混流泵性能曲线图与性能参数表 Curve and specification

900QZ-85

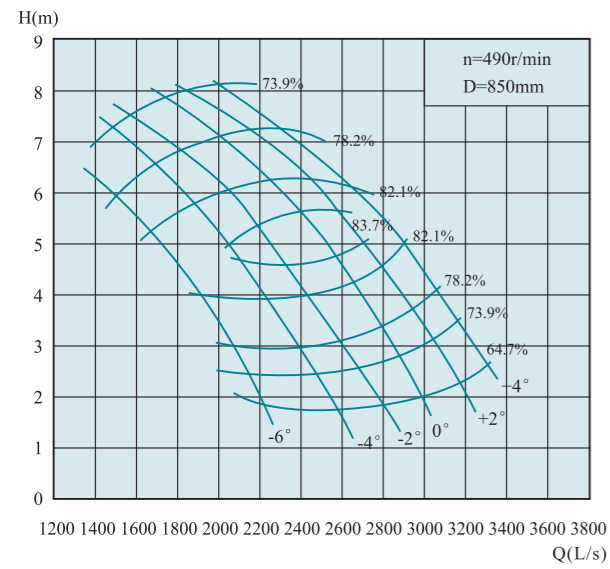

叶片安装角度 Angle	流量Q Capacity		扬程H Head (m)	转速n Speed (r/min)	功率P Power(kw)		效率η Eff. (%)	叶轮直径 Diameter of impeller (mm)
	(m³/h)	(L/s)			轴功率 Shaft power	电机功率 Motor power		
-6°	7498.8	2083	2.56	490	70.7	132	74	850
	6862.3	1906.2	3.89		87.6		83	
	4842.4	1345.1	6.55		116.8		74	
-4°	8688.6	2413.5	2.48		79.3	160	74	
	7415.6	2059.9	4.77		114.8		84	
	5312.9	1475.8	6.96		136.2		74	
-2°	9767.9	2713.3	2.56		92.1	185	74	
	8439.5	2344.3	4.68		128.1		84	
	5838.5	1621.8	7.29		156.7		74	
0°	10514.9	2920.8	2.8		108.4	220	74	
	9241.9	2567.2	4.85		143.7		85	
	6419.5	1783.2	7.56		178.7		74	
+2°	11234.5	3120.7	3.21	132.8	250	74		
	9878.4	2744	5.18	166		84		
	7000.9	1944.7	7.78	200.6		74		
+4°	11953.8	3320.5	3.6	158.5		74		
	10099.8	2805.5	5.86	194.3		83		
	7637	2121.4	7.77	218.5		74		

900QZ-100

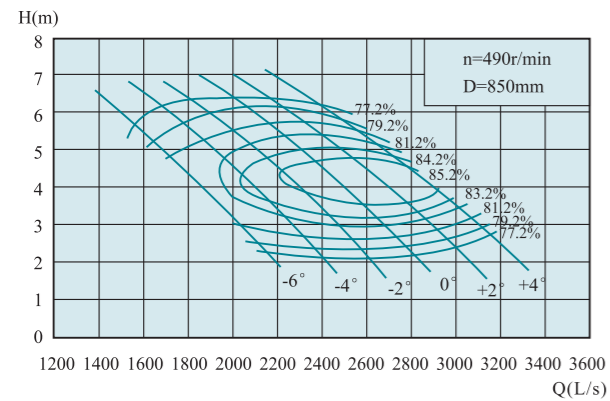

叶片安装角度 Angle	流量Q Capacity		扬程H Head (m)	转速n Speed (r/min)	功率P Power(kw)		效率η Eff. (%)	叶轮直径 Diameter of impeller (mm)
	(m³/h)	(L/s)			轴功率 Shaft power	电机功率 Motor power		
-6°	7360.6	2044.6	2.93	490	72.4	110	81.2	850
	6917.8	1921.6	3.69		84		82.8	
	6225.8	1729.4	4.86		101.5		81.2	
-4°	8412.1	2336.7	2.69		75.9	132	81.2	
	7747.9	2152.2	3.76		94.2		84.3	
	6765.5	1879.3	5.27		119.7		81.2	
-2°	9159.1	2544.2	2.61		80.2	160	81.2	
	8439.5	2344.3	3.86		104.6		84.9	
	7249.7	2013.8	5.53		134.5		81.2	
0°	9878.4	2744	2.7		89.5	185	81.2	
	9131.4	2536.5	3.85		112.4		85.2	
	7789.3	2163.7	5.73		149.8		81.2	
+2°	10514.9	2920.8	2.91	102.7		81.2		
	9684.7	2690.2	4.06	125		85.7		
	8412.1	2336.7	5.75	162.3		81.2		
+4°	11068.2	3074.5	3.19	118.5		81.5		
	10376.6	2882.4	4.08	135.1		85.4		
	9269.6	2574.9	5.5	171.1		81.2		

QZ、QH型潜水轴流泵、混流泵性能曲线图与性能参数表 Curve and specification

900QZ-125

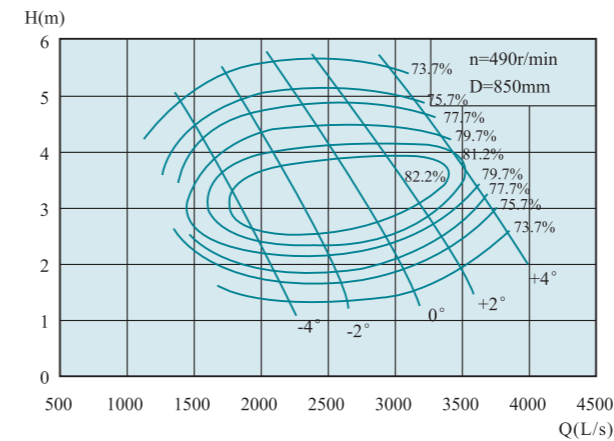

叶片安装角度 Angle	流量Q Capacity		扬程H Head (m)	转速n Speed (r/min)	功率P Power(kw)		效率η Eff. (%)	叶轮直径 Diameter of impeller (mm)
	(m³/h)	(L/s)			轴功率 Shaft power	电机功率 Motor power		
-4°	7526.5	2090.7	1.87	490	49.4	110	77.7	850
	6862.3	1906.2	2.78		63.2		82.2	
	5478.8	1521.9	4.52		89.1		75.7	
-2°	9214.6	2559.6	1.86		60.1	132	77.7	
	8494.9	2359.7	2.88		80.7		82.6	
	6696.4	1860.1	4.9		118.1		75.7	
0°	10874.5	3020.7	2.09		79.7	160	77.7	
	10017	2782.5	3.17		104		83.2	
	8052.1	2236.7	5.13		148.7		75.7	
+2°	12092	3358.9	2.48		105.2	185	77.7	
	11123.6	3089.9	3.28		120.4		82.6	
	9325.1	2590.3	5.13		172.2		75.7	
+4°	13199	3666.4	3.17	146.7	220	77.7		
	12645.7	3512.7	3.63	153.5		81.5		
	11289.6	3136	4.96	201.6		75.7		

900QZ-160

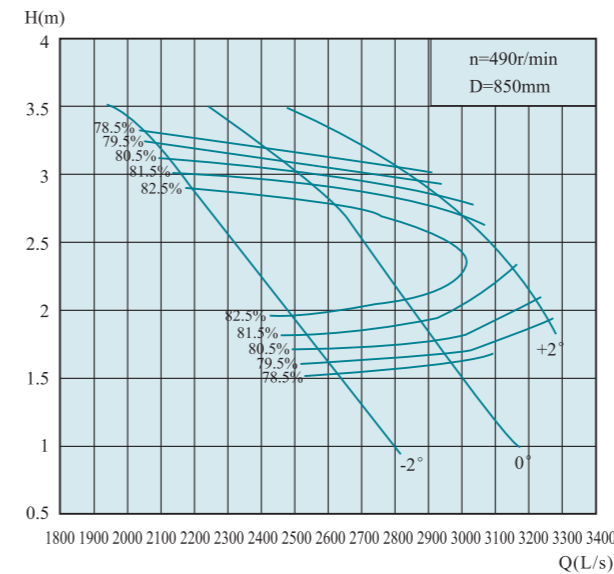

叶片安装角度 Angle	流量Q Capacity		扬程H Head (m)	转速n Speed (r/min)	功率P Power(kw)		效率η Eff. (%)	叶轮直径 Diameter of impeller (mm)
	(m³/h)	(L/s)			轴功率 Shaft power	电机功率 Motor power		
-2°	9370.4	2602.9	1.61	490	51.7	90	79.5	850
	8578.1	2382.8	2.28		63.4		84	
	7512.1	2086.7	3.24		83.4		79.5	
0°	10590.5	2941.8	1.67		60.6	110	79.5	
	9961.6	2767.1	2.29		74.9		83	
	8873.6	2464.9	3.1		94.3		79.5	
+2°	11735.6	3259.9	1.93		77.6		79.5	
	11123.6	3089.9	2.48		92.2		81.5	
	10305.4	2862.6	2.96		104.6		79.5	

QZ、QH型潜水轴流泵、混流泵性能曲线图与性能参数表 Curve and specification

900QH-50

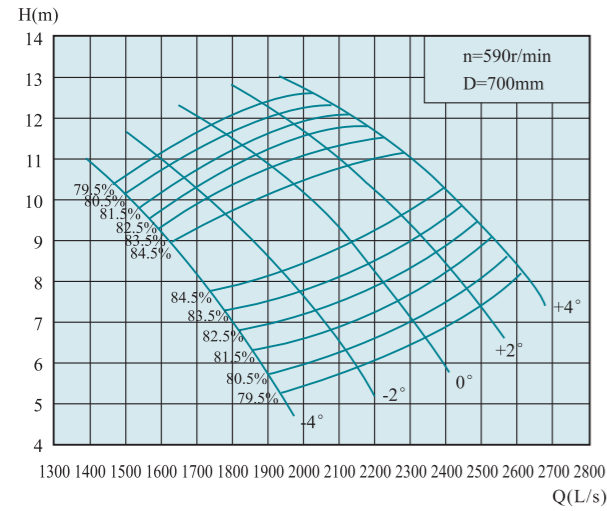

叶片安装角度 Angle	流量Q Capacity		扬程H Head (m)	转速n Speed (r/min)	功率P Power(kw)		效率η Eff. (%)	叶轮直径 Diameter of impeller (mm)
	(m³/h)	(L/s)			轴功率 Shaft power	电机功率 Motor power		
-4°	6866.6	1907.4	5.72	590	132.8	200	80.6	700
	5954.8	1654.1	8.74		167.6	200	84.6	
	5378	1493.9	10.14		184.4	200	80.6	
-2°	7629.5	2119.3	6.31		162.8	220	80.6	
	6513.1	1809.2	9.46		198.2	220	84.7	
	5843.2	1623.1	10.82		213.8	220	80.6	
0°	8318.2	2310.6	7.03		197.7	280	80.6	
	7257.2	2015.9	9.92		231.9	280	84.6	
	6438.6	1788.5	11.58		252.1	280	80.6	
+2°	8839.1	2455.3	7.84		234.3	315	80.6	
	7629.5	2119.3	10.82		265.9	315	84.6	
	6997	1943.6	12.08		285.8	315	80.6	
+4°	9267.1	2574.2	8.56	268.2	355	80.6		
	8187.8	2274.4	11.18	294.9	355	84.6		
	7480.8	2078	12.35	312.4	355	80.6		

900QH-50D

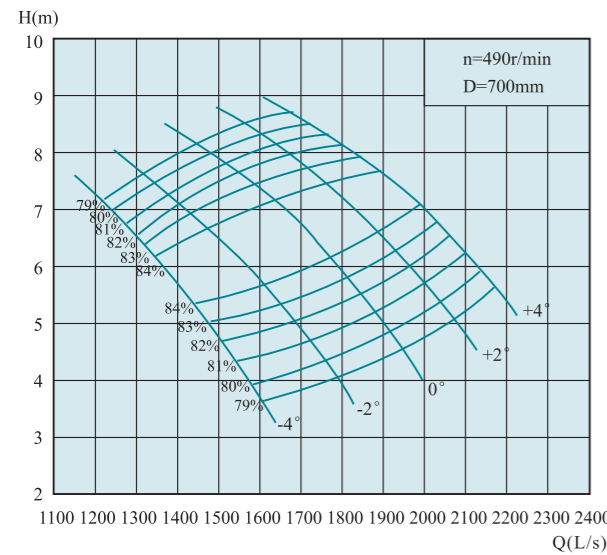

叶片安装角度 Angle	流量Q Capacity		扬程H Head (m)	转速n Speed (r/min)	功率P Power(kw)		效率η Eff. (%)	叶轮直径 Diameter of impeller (mm)
	(m³/h)	(L/s)			轴功率 Shaft power	电机功率 Motor power		
-4°	5702.8	1584.1	3.95	490	76.6	110	80.1	700
	4945.7	1373.8	6.03		96.6	110	84.1	
	4466.5	1240.7	6.99		106.2	110	80.1	
-2°	6336.4	1760.1	4.35		93.8	132	80.1	
	5409	1502.5	6.53		114.3	132	84.2	
	4852.8	1348	7.46		123.2	132	80.1	
0°	6908.4	1919	4.85		114	160	80.1	
	6027.5	1674.3	6.84		133.6	160	84.1	
	5347.4	1485.4	7.99		145.4	160	80.1	
+2°	7341.1	2039.2	5.41		135.1	185	80.1	
	6336.4	1760.1	7.46		153.2	185	84.1	
	5811.1	1614.2	8.33		164.7	185	80.1	
+4°	7696.4	2137.9	5.91	154.7	185	80.1		
	6800	1888.9	7.71	169.9	185	84.1		
	6212.9	1725.8	8.52	180.1	185	80.1		

外形安装尺寸图 Outline installation dimension drawing

900QZ-50, 900QZ-70, 900QZ-85, 900QZ-100, 900QZ-160
900QH-50, 900QH-50D

1、井筒悬吊式安装
Suspension installation of wellbore

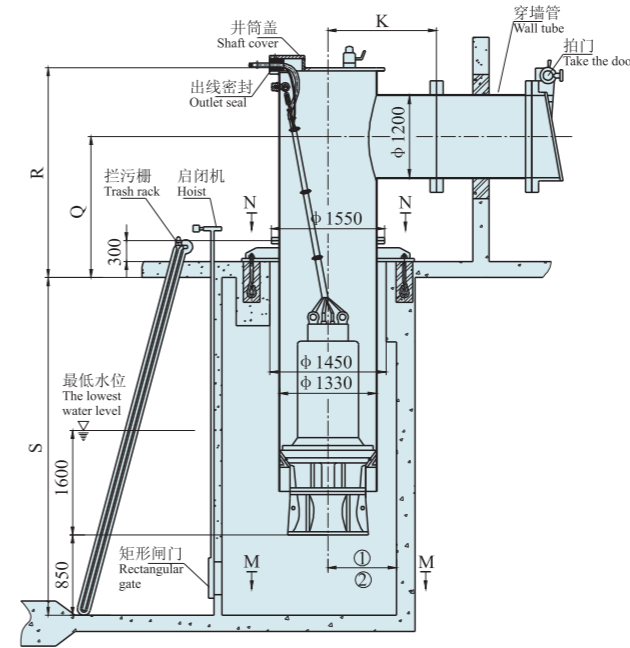

2、混凝土预制井筒式安装
Precast concrete shaft installation

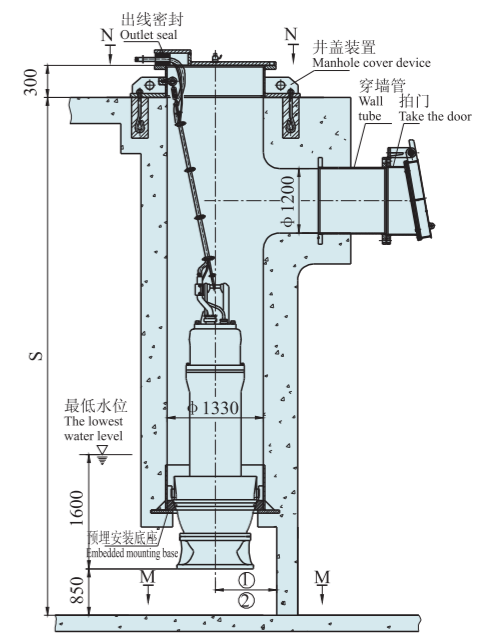

3、弯管悬吊式安装
Bend suspension installation

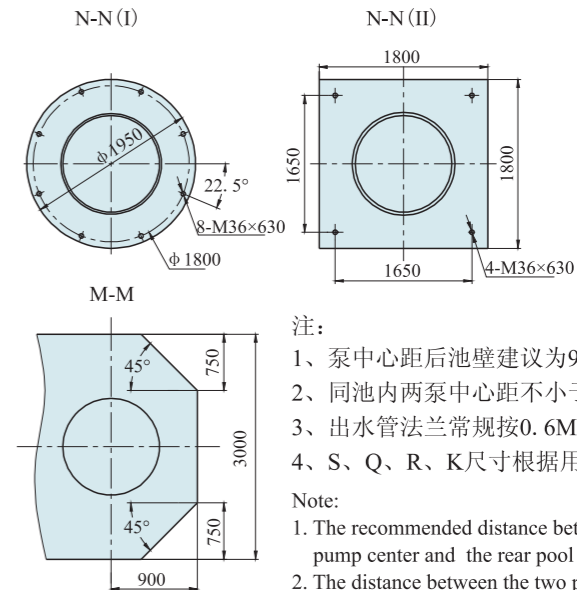
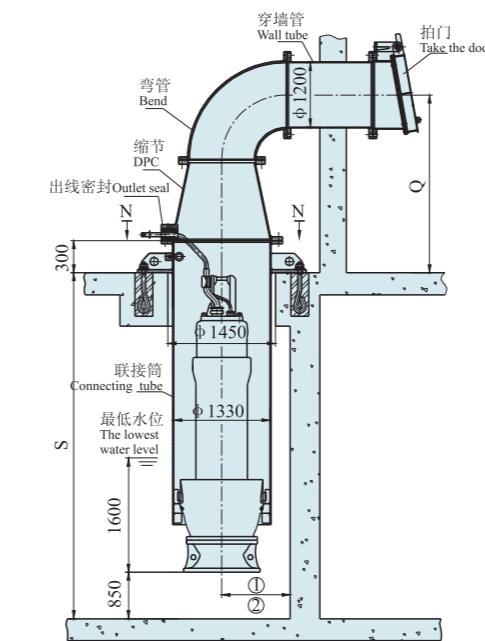

- 注:
- 1、泵中心距后池壁建议为900;
 - 2、同池内两泵中心距不小于3000;
 - 3、出水管法兰常规按0.6MPa;
 - 4、S、Q、R、K尺寸根据用户要求。
- Note:
1. The recommended distance between the pump center and the rear pool wall is 900;
 2. The distance between the two pump centers in the same pool shall not be less than 3000;
 3. The outlet pipe flange is normally 0.6mpa;
 4. Sizes of S, Q, R and K are according to user requirements.

QZ、QH型潜水轴流泵、混流泵性能曲线图与性能参数表 Curve and specification

900QH-40

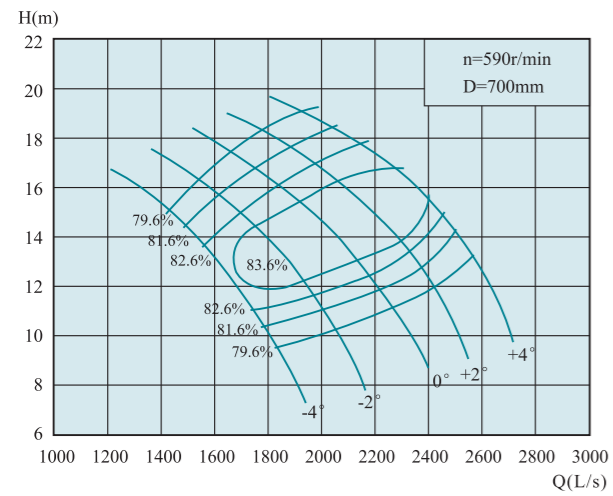

叶片安装角度 Angle	流量Q Capacity		扬程H Head (m)	转速n Speed (r/min)	功率P Power(kw)		效率η Eff. (%)	叶轮直径 Diameter of impeller (mm)
	(m³/h)	(L/s)			轴功率 Shaft power	电机功率 Motor power		
-4°	6606	1835	9.58	590	216.6	280	79.6	700
	6048	1680	12.3		243.1	280	83.4	
	5191.9	1442.2	15.23		270.7	280	79.6	
-2°	7406.3	2057.3	10.33		261.9	355	79.6	
	6699.2	1860.9	13.34		291.3	355	83.6	
	5582.5	1550.7	16.43		314	355	79.6	
0°	8132	2258.9	11.15		310.4	400	79.6	
	7257.2	2015.9	14.51		342	400	83.9	
	6010.6	1669.6	17.64		363	400	79.6	
+2°	8727.5	2424.3	12.06		360.3	450	79.6	
	7815.6	2171	15.32		385.7	450	84.6	
	6419.9	1783.3	18.52		407	450	79.6	
+4°	9248.4	2569	13.3		421.1	500	79.6	
	8374	2326.1	16.41		445.3	500	84.1	
	6978.2	1938.4	19.27		460.3	500	79.6	

900QH-40D

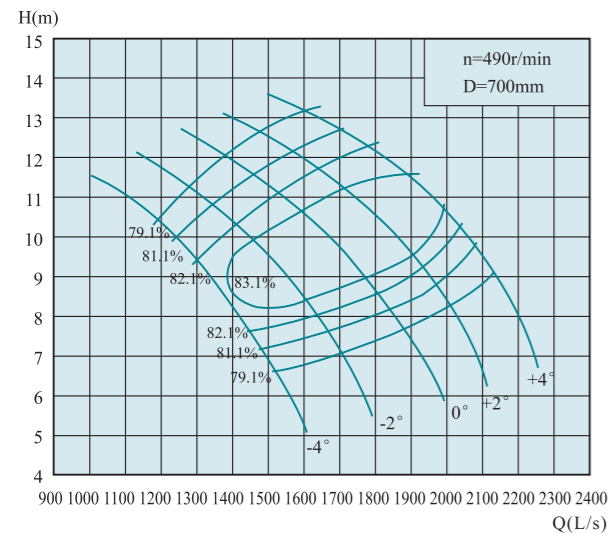

叶片安装角度 Angle	流量Q Capacity		扬程H Head (m)	转速n Speed (r/min)	功率P Power(kw)		效率η Eff. (%)	叶轮直径 Diameter of impeller (mm)
	(m³/h)	(L/s)			轴功率 Shaft power	电机功率 Motor power		
-4°	5486.4	1524	6.61	490	124.9	160	79.1	700
	5022.7	1395.2	8.49		140.2	160	82.9	
	4311.7	1197.7	10.51		156.1	160	79.1	
-2°	6151	1708.6	7.13		151.1	185	79.1	
	5563.8	1545.5	9.2		167.9	185	83.1	
	4636.4	1287.9	11.33		181	185	79.1	
0°	6753.6	1876	7.69		178.9	220	79.1	
	6027.5	1674.3	10.01		197.1	220	83.4	
	4991.8	1386.6	12.17		209.3	220	79.1	
+2°	7248.2	2013.4	8.32		207.8	250	79.1	
	6491.2	1803.1	10.57		222.3	250	84.1	
	5332	1481.1	12.78		234.8	250	79.1	
+4°	7681	2133.6	9.17		242.6	280	79.1	
	6954.5	1931.8	11.32		256.6	280	83.6	
	5795.6	1609.9	13.29		265.3	280	79.1	

QZ、QH型潜水轴流泵、混流泵性能曲线图与性能参数表 Curve and specification

1000QZ-50

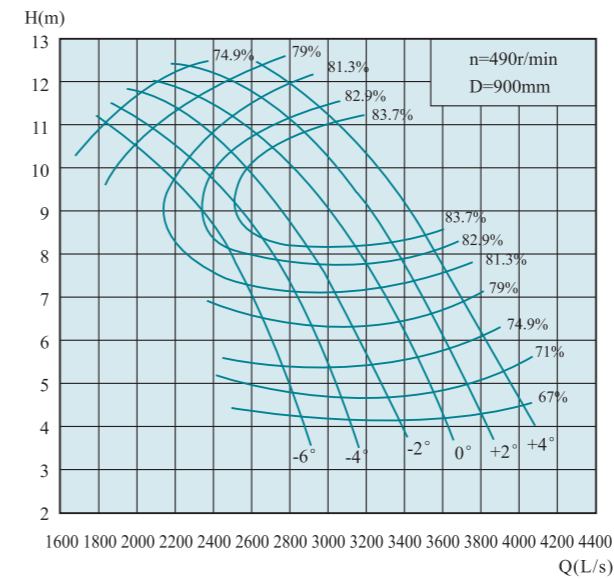

叶片安装角度 Angle	流量Q Capacity		扬程H Head (m)	转速n Speed (r/min)	功率P Power(kw)		效率η Eff. (%)	叶轮直径 Diameter of impeller (mm)
	(m³/h)	(L/s)			轴功率 Shaft power	电机功率 Motor power		
-6°	10042.6	2789.6	4.8	490	185	280	71	900
	8474	2353.9	8.77		243.4	280	83.2	
	6709.3	1863.7	11.04		265.9	280	75.9	
-4°	10905.8	3029.4	4.71		197.1	315	71	
	9213.5	2559.3	9.04		268.9	315	84.4	
	6922.8	1923	11.56		287.3	315	75.9	
-2°	11773.1	3270.3	4.71		212.8	355	71	
	9491	2636.4	9.31		285.3	355	84.4	
	7264.8	2018	11.88		309.9	355	75.9	
0°	12713.4	3531.5	4.93		240.6	355	71	
	10542.6	2928.5	9.35		317.5	355	84.6	
	8418.6	2338.5	11.72		340.3	355	79	
+2°	13482.7	3745.2	5.04		260.8	400	71	
	11098.1	3082.8	9.59		343.6	400	84.4	
	9059.8	2516.6	12.11		378.4	400	79	
+4°	13995.4	3887.6	5.47		293.8	450	71	
	11670.5	3241.8	9.85		371.1	450	84.4	
	9487.1	2635.3	12.33		403.5	450	79	

1000QZ-70

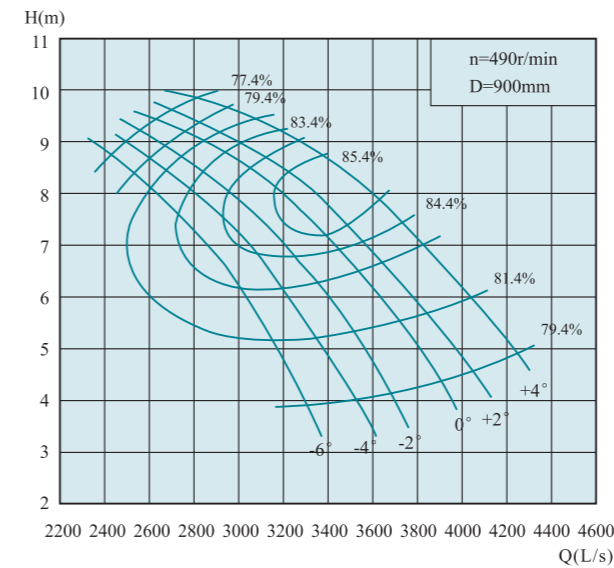

叶片安装角度 Angle	流量Q Capacity		扬程H Head (m)	转速n Speed (r/min)	功率P Power(kw)		效率η Eff. (%)	叶轮直径 Diameter of impeller (mm)
	(m³/h)	(L/s)			轴功率 Shaft power	电机功率 Motor power		
-6°	11824.9	3284.7	3.85	490	156.2	280	79.4	900
	10510.9	2919.7	6.78		232.8	280	83.4	
	8704.4	2417.9	8.74		267.8	280	77.4	
-4°	12646.1	3512.8	3.96		171.9	315	79.4	
	10773.7	2992.7	7.19		249.5	315	84.6	
	9032.8	2509.1	9.13		290.3	315	77.4	
-2°	13303.1	3695.3	4.11		187.5	355	79.4	
	11332.1	3147.8	7.5		273.1	355	84.8	
	9230	2563.9	9.25		300.6	355	77.4	
0°	13960.1	3877.8	4.42		211.8	355	79.4	
	11792.2	3275.6	7.83		292.9	355	85.9	
	9460.1	2627.8	9.56		318.4	355	77.4	
+2°	1452.6	4014.6	4.62		229.2	400	79.4	
	12087.7	3357.7	7.91		301.9	400	86.3	
	9558.4	2655.1	9.66		325.1	400	77.4	
+4°	15175.4	4215.4	5.04		262.5	400	79.4	
	12547.4	3485.4	8.43		337.5	400	85.4	
	10149.8	2819.4	9.87		352.7	400	77.4	

QZ、QH型潜水轴流泵、混流泵性能曲线图与性能参数表 Curve and specification

1000QZ-85

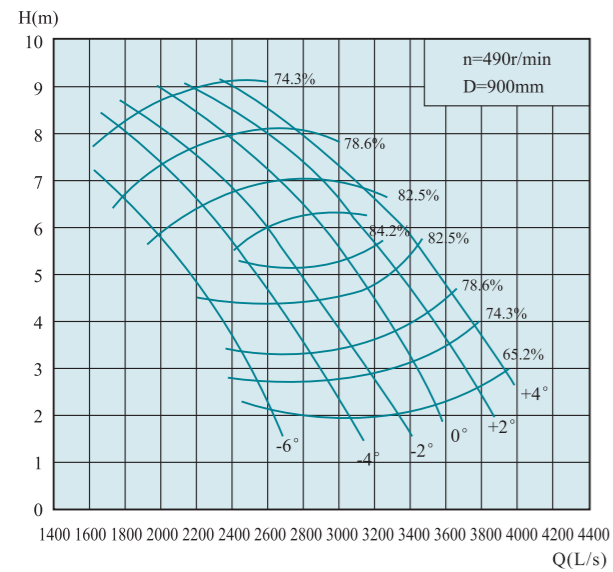

叶片安装角度 Angle	流量Q Capacity		扬程H Head (m)	转速n Speed (r/min)	功率P Power(kw)		效率η Eff. (%)	叶轮直径 Diameter of impeller (mm)
	(m³/h)	(L/s)			轴功率 Shaft power	电机功率 Motor power		
-6°	8901.4	2472.6	2.87	490	93.6	160	74.4	900
	8146.1	2262.8	4.36		116		83.4	
	5748.1	1596.7	7.35		154.7		74.4	
-4°	10314	2865	2.77		104.6	185	74.4	
	8803.1	2445.3	5.34		151.8		84.4	
	6306.5	1751.8	7.8		180.2		74.4	
-2°	11594.9	3220.8	2.87		121.9	220	74.4	
	10018.4	2782.9	5.24		169.5		84.4	
	6930.7	1925.2	8.17		207.4		74.4	
0°	12481.9	3467.2	3.13		143.1	250	74.4	
	10971	3047.5	5.44		190.4		85.4	
	7620.5	2116.8	8.48		236.7		74.4	
+2°	13335.8	3704.4	3.6	175.8	280	74.4		
	11726.3	3257.3	5.81	220		84.4		
	8310.2	2308.4	8.73	265.7		74.4		
+4°	14189.8	3941.6	4.04	210	315	74.4		
	11989.1	3330.3	6.57	257.4		83.4		
	9065.9	2518.3	8.72	289.5		74.4		

QZ、QH型潜水轴流泵、混流泵性能曲线图与性能参数表 Curve and specification

1000QZ-125

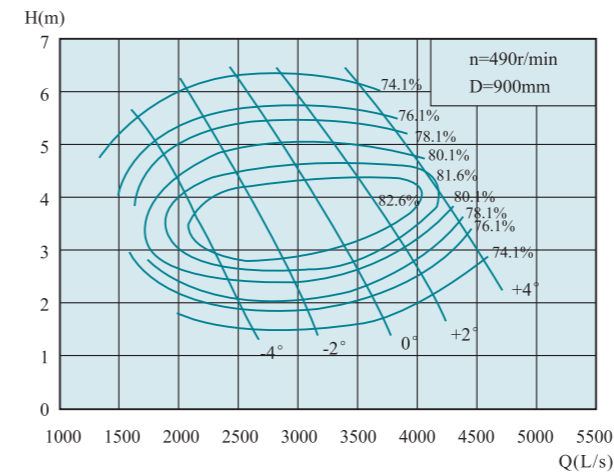

叶片安装角度 Angle	流量Q Capacity		扬程H Head (m)	转速n Speed (r/min)	功率P Power(kw)		效率η Eff. (%)	叶轮直径 Diameter of impeller (mm)
	(m³/h)	(L/s)			轴功率 Shaft power	电机功率 Motor power		
-4°	8934.5	2481.8	2.1	490	65.5	132	78.1	900
	8146.1	2262.8	3.11		83.6		82.6	
	6503.8	1806.6	5.07		118.1		76.1	
-2°	10937.9	3038.3	2.09		79.8	160	78.1	
	10084	2801.1	3.23		106.9		83	
	7948.8	2208	5.49		156.3		76.1	
0°	12908.9	3585.8	2.34		105.4	220	78.1	
	11890.4	3302.9	3.56		138		83.6	
	9558.4	2655.1	5.76		197.1		76.1	
+2°	14353.9	3987.2	2.77		138.7	250	78.1	
	13204.4	3667.9	3.68		159.5		83	
	11069.3	3074.8	5.76		228.3		76.1	
+4°	15667.9	4352.2	3.56	194.6	280	78.1		
	15010.9	4169.7	4.07	203.3		81.9		
	13401.4	3722.6	5.56	266.8		76.1		

1000QZ-100

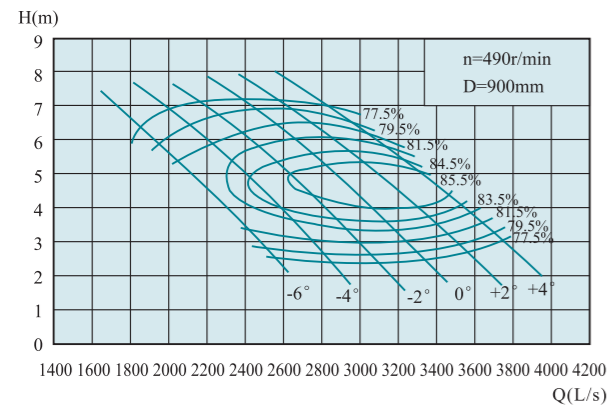

叶片安装角度 Angle	流量Q Capacity		扬程H Head (m)	转速n Speed (r/min)	功率P Power(kw)		效率η Eff. (%)	叶轮直径 Diameter of impeller (mm)
	(m³/h)	(L/s)			轴功率 Shaft power	电机功率 Motor power		
-6°	87.7.2	2427	3.29	490	96.1	160	81.5	900
	8211.6	2281	4.14		111.5		83.1	
	7390.4	2052.9	5.45		134.7		81.5	
-4°	9985.3	2773.7	3.01		100.5	185	81.5	
	9197.3	2554.8	4.21		124.7		84.6	
	8031.2	2230.9	5.91		158.7		81.5	
-2°	10872.4	3020.1	2.93		106.5	220	81.5	
	10018.4	2782.9	4.33		138.7		85.2	
	8605.8	2390.5	6.2		178.4		81.5	
0°	11726.3	3257.3	3.02		118.4	250	81.5	
	10839.6	3011	4.32		149.2		85.5	
	9246.2	2568.4	6.42		198.5		81.5	
+2°	12481.9	3467.2	3.26	136.1	280	81.5		
	11496.2	3193.4	4.55	165.7		85		
	9985.3	2773.7	6.44	215		81.5		
+4°	13138.9	3649.7	3.58	157.3	315	81.5		
	12317.8	3421.6	4.57	179		85.7		
	11003.8	3056.6	6.17	227		81.5		

1000QZ-160

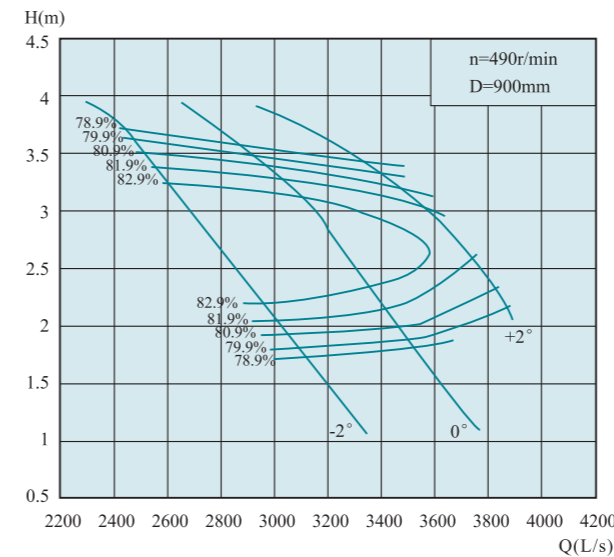

叶片安装角度 Angle	流量Q Capacity		扬程H Head (m)	转速n Speed (r/min)	功率P Power(kw)		效率η Eff. (%)	叶轮直径 Diameter of impeller (mm)	
	(m³/h)	(L/s)			轴功率 Shaft power	电机功率 Motor power			
-2°	11123.3	3089.8	1.81	490	68.7	132	79.9	900	
	10182.6	2828.5	2.56		84.2		84.4		
	8917.2	2477	3.63		110.4		79.9		
0°	12571.6	3492.1	1.87		80.2	220	79.9		
	11824.9	3284.7	2.57		99.3		83.4		
	10533.2	2925.9	3.47		124.7		79.9		
+2°	13930.6	3869.6	2.16		102.6	280	79.9		
	13204.4	3667.9	2.77		121.7		160		81.9
	12233.2	3398.1	3.32		138.5		79.9		

QZ、QH型潜水轴流泵、混流泵性能曲线图与性能参数表 Curve and specification

1000QH-40

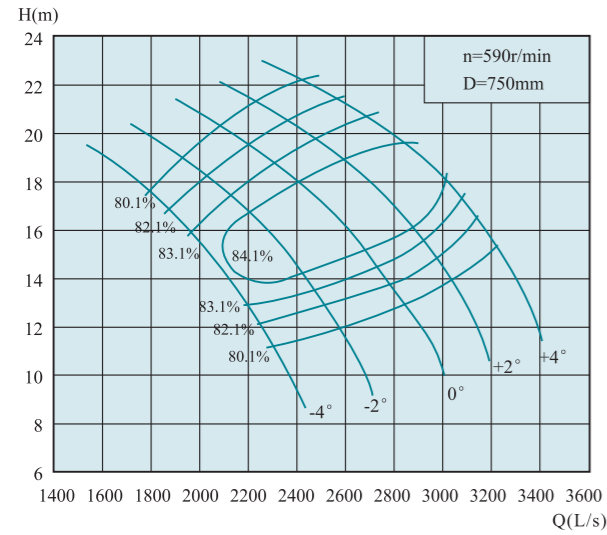

叶片安装角度 Angle	流量Q Capacity		扬程H Head (m)	转速n Speed (r/min)	功率P Power(kw)		效率η Eff. (%)	叶轮直径 Diameter of impeller (mm)
	(m³/h)	(L/s)			轴功率 Shaft power	电机功率 Motor power		
-4°	8288.6	2302.4	11.15	590	314.4	450	80.1	750
	7588.4	2107.9	14.31		352.7	450	83.9	
	6514.2	1809.5	17.72		392.7	450	80.1	
-2°	9292.7	2581.3	12.02		380	500	80.1	
	8405.6	2334.9	15.52		422.7	500	84.1	
	7004.5	1945.7	19.12		455.6	500	80.1	
0°	10203.5	2834.3	12.97		450.2	560	80.1	
	9105.8	2529.4	16.88		496.3	560	84.1	
	7541.6	2094.9	20.52		526.5	560	80.1	
+2°	10950.5	3041.8	14.03		522.7	630	80.1	
	9806.4	2724	17.83		559.9	630	85.1	
	8055.4	2237.6	21.55		590.6	630	80.1	
+4°	11604.2	3223.4	15.47		610.7	710	80.1	
	10507	2918.6	19.08		645.7	710	84.6	
	8755.9	2432.2	22.42		667.8	710	80.1	

1000QH-40D

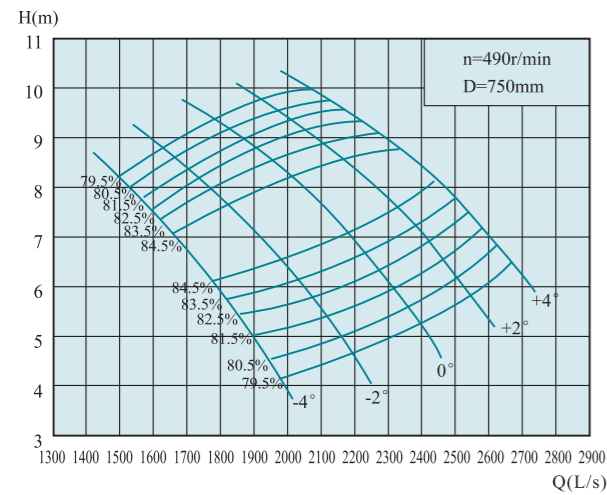

叶片安装角度 Angle	流量Q Capacity		扬程H Head (m)	转速n Speed (r/min)	功率P Power(kw)		效率η Eff. (%)	叶轮直径 Diameter of impeller (mm)
	(m³/h)	(L/s)			轴功率 Shaft power	电机功率 Motor power		
-4°	6748.2	1874.5	7.59	490	175.6	250	79.5	750
	6178	1716.1	9.74		196.8	250	83.3	
	5303.5	1473.2	12.06		219.2	250	79.5	
-2°	7565.4	2101.5	8.18		212.1	280	79.5	
	6843.2	1900.9	10.56		235.8	280	83.5	
	5702.8	1584.1	13.01		254.3	280	79.5	
0°	8306.6	2307.4	8.83		251.4	315	79.5	
	7413.5	2059.3	11.49		277	315	83.8	
	6139.8	1705.5	13.97		294	315	79.5	
+2°	8915	2476.4	9.55		291.8	355	79.5	
	7983.7	2217.7	12.13		312.3	355	84.5	
	6558.1	1821.7	14.67		329.8	355	79.5	
+4°	9447.1	2624.2	10.53		341	400	79.5	
	8554	2376.1	12.99		360.5	400	84	
	7128.4	1980.1	15.26		372.9	400	79.5	

QZ、QH型潜水轴流泵、混流泵性能曲线图与性能参数表 Curve and specification

1000QH-50

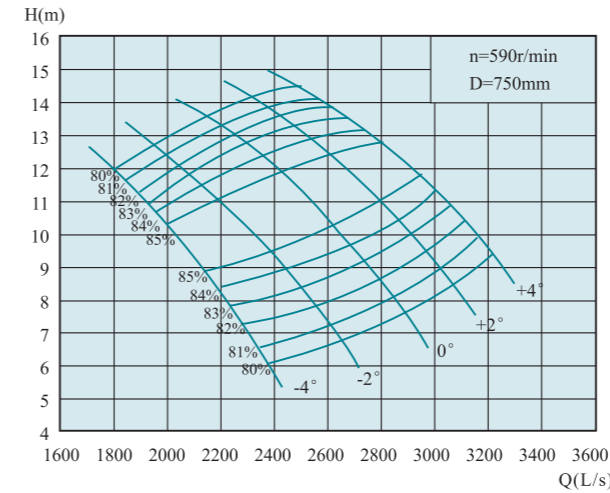

叶片安装角度 Angle	流量Q Capacity		扬程H Head (m)	转速n Speed (r/min)	功率P Power(kw)		效率η Eff. (%)	叶轮直径 Diameter of impeller (mm)
	(m³/h)	(L/s)			轴功率 Shaft power	电机功率 Motor power		
-4°	8445.6	2346	6.57	590	186.7	280	81	750
	7324.2	2034.5	10.04		235.7	280	85	
	6614.6	1837.4	11.64		259	280	81	
-2°	9384.1	2606.7	7.24		228.6	315	81	
	8010.7	2225.2	10.87		278.8	315	85.1	
	7186.7	1996.3	12.42		300.3	315	81	
0°	10230.8	2841.9	8.07		277.8	400	81	
	8926.2	2479.5	11.38		325.7	400	85	
	7919.3	2199.8	13.3		354.3	400	81	
+2°	10871.6	3019.9	9		329.2	450	81	
	9384.1	2606.7	12.42		373.6	450	85	
	8605.8	2390.5	13.87		401.6	450	81	
+4°	11398.3	3166.2	9.83		376.9	450	81	
	10070.6	2797.4	12.83		414.2	450	85	
	9200.9	2555.8	14.18		438.9	450	81	

1000QH-50D

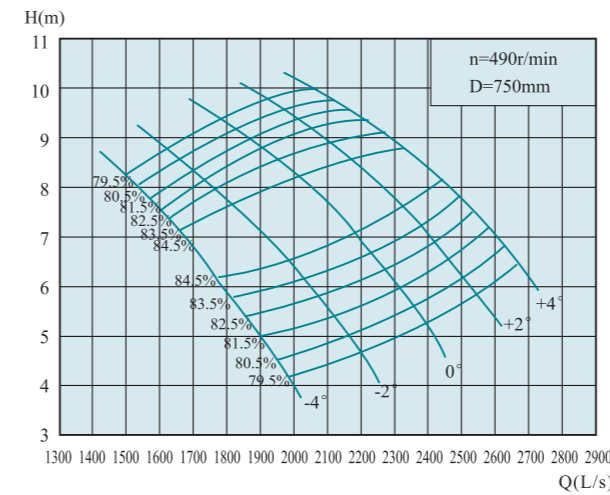

叶片安装角度 Angle	流量Q Capacity		扬程H Head (m)	转速n Speed (r/min)	功率P Power(kw)		效率η Eff. (%)	叶轮直径 Diameter of impeller (mm)
	(m³/h)	(L/s)			轴功率 Shaft power	电机功率 Motor power		
-4°	7014.2	1948.4	4.53	490	107.6	160	80.5	750
	6082.9	1689.7	6.92		135.7	160	84.5	
	5493.6	1526	8.03		149.3	160	80.5	
-2°	7793.6	2164.9	5		131.9	185	80.5	
	6653.2	1848.1	7.49		160.5	185	84.6	
	5968.8	1658	8.56		173	185	80.5	
0°	8496.7	2360.2	5.57		160.2	220	80.5	
	7413.5	2059.3	7.85		187.7	220	84.5	
	6576.8	1826.9	9.17		204.2	220	80.5	
+2°	9029.2	2508.1	6.21		189.8	250	80.5	
	7793.6	2164.9	8.56		215.1	250	84.5	
	7147.1	1985.3	9.56		231.3	250	80.5	
+4°	9466.2	2629.5	6.78		217.3	280	80.5	
	8363.9	2323.3	8.85		238.7	280	84.5	
	7641.4	2122.6	9.78		253	280	80.5	

外形安装尺寸图 Outline installation dimension drawing

900QH-40, 900QH-40D, 1000QH-40, 1000QH-40D, 1000QH-50, 1000QH-50D
1000QZ-50, 1000QZ-70, 1000QZ-85, 1000QZ-100, 1000QZ-125, 1000QZ-160

1、井筒悬吊式安装
Suspension installation of wellbore

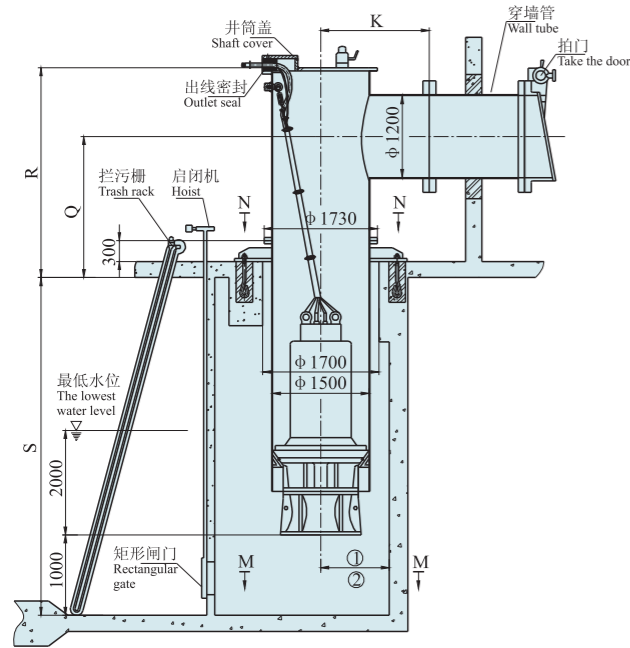

2、混凝土预制井筒式安装
Precast concrete shaft installation

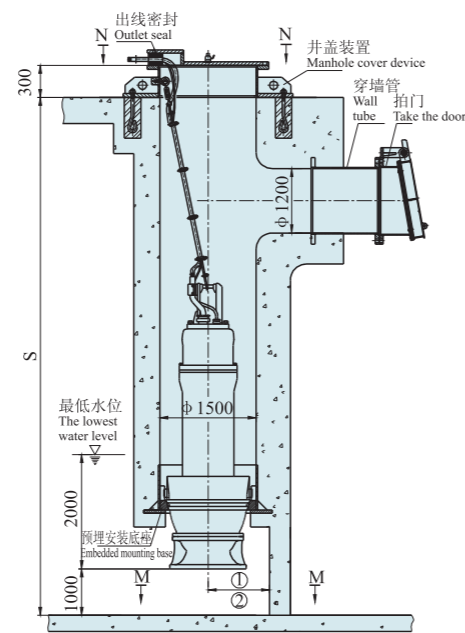

3、弯管悬吊式安装
Bend suspension installation

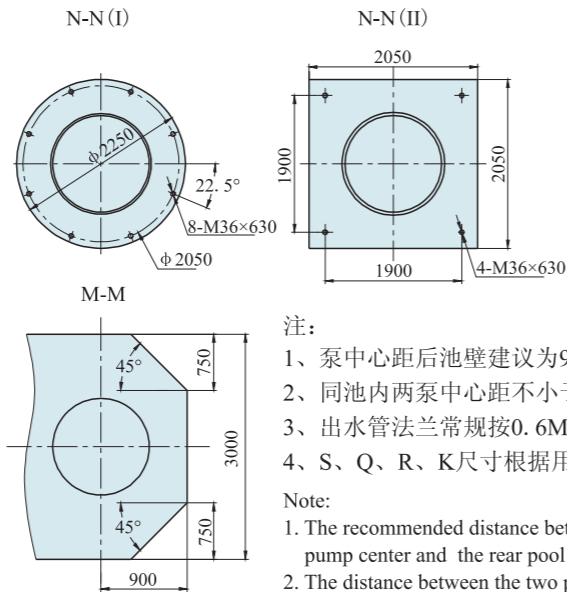
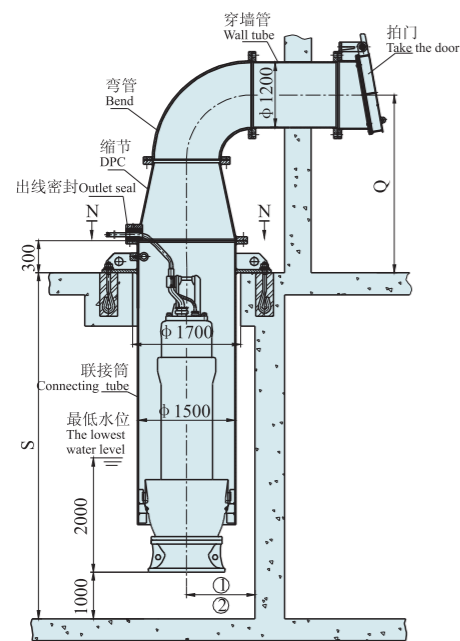

- 注:
- 1、泵中心距后池壁建议为900;
 - 2、同池内两泵中心距不小于3000;
 - 3、出水管法兰常规按0.6MPa;
 - 4、S、Q、R、K尺寸根据用户要求。

- Note:
1. The recommended distance between the pump center and the rear pool wall is 900;
 2. The distance between the two pump centers in the same pool shall not be less than 3000;
 3. The outlet pipe flange is normally 0.6mpa;
 4. Sizes of S, Q, R and K are according to user requirements.

QZ、QH型潜水轴流泵、混流泵性能曲线图与性能参数表 Curve and specification

1000QH-40C

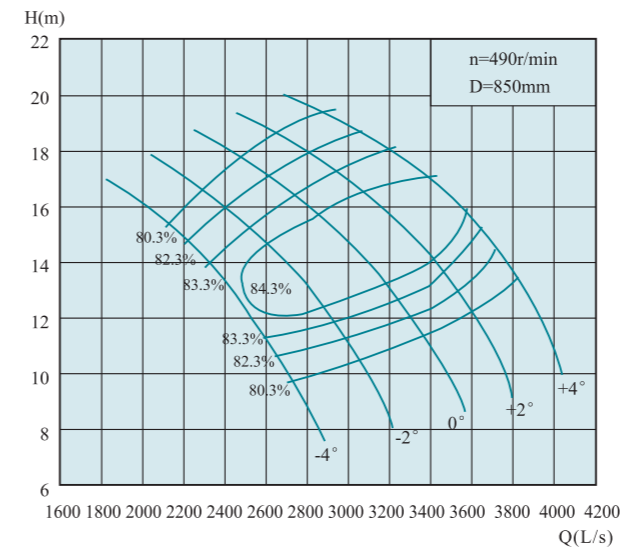

叶片安装角度 Angle	流量Q Capacity		扬程H Head (m)	转速n Speed (r/min)	功率P Power(kw)		效率η Eff. (%)	叶轮直径 Diameter of impeller (mm)				
	(m³/h)	(L/s)			轴功率 Shaft power	电机功率 Motor power						
-4°	9823.3	2728.7	9.75	490	325	450	80.3	850				
	8993.2	2498.1	12.51		364.5	450	84.1					
	7720.2	2144.5	15.49		405.8	450	80.3					
-2°	11013.1	3059.2	10.51		392.8	500	80.3		850			
	9961.6	2767.1	13.57		437	500	84.3			470.7		
	8301.2	2305.9	16.71		470.7	500	80.3					
0°	12092	3358.9	11.34		465.3	560	80.3			850		
	10791.7	2997.7	14.76		513.1	560	84.6				544.1	
	8937.7	2482.7	17.94		544.1	560	80.3					
+2°	12977.6	3604.9	12.27		540.4	650	80.3				850	
	11621.9	3228.3	15.58		578.4	650	85.3					610.3
	9546.5	2651.8	18.84		610.3	650	80.3					
+4°	13752.4	3820.1	13.52	631	750	80.3	850					
	12452	3458.9	16.68	667.4	750	84.8		690.2				
	10376.6	2882.4	19.6	690.2	750	80.3						

1000QH-50C

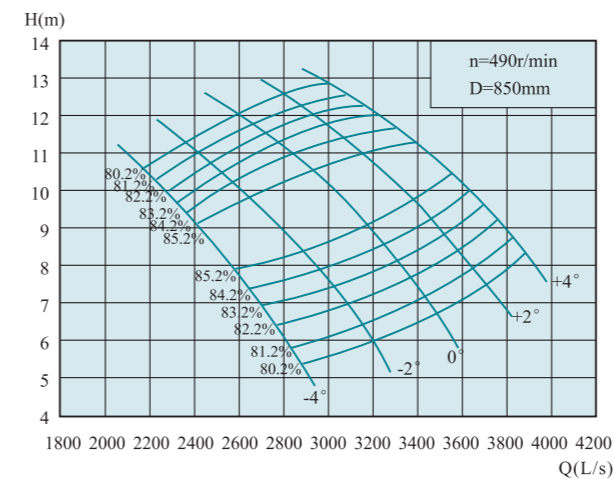

叶片安装角度 Angle	流量Q Capacity		扬程H Head (m)	转速n Speed (r/min)	功率P Power(kw)		效率η Eff. (%)	叶轮直径 Diameter of impeller (mm)				
	(m³/h)	(L/s)			轴功率 Shaft power	电机功率 Motor power						
-4°	10210.7	2836.3	5.82	490	199.4	315	81.2	850				
	8854.6	2459.6	8.89		251.8	315	85.2		276.7			
	7997	2221.4	10.31		276.7	315	81.2					
-2°	11345	3151.4	6.42		244.4	355	81.2		850			
	9684.7	2690.2	9.63		297.9	355	85.3			320.7		
	8688.6	2413.5	11		320.7	355	81.2					
0°	12368.9	3435.8	7.15		296.8	400	81.2			850		
	10791.7	2997.7	10.08		347.9	400	85.2				378.5	
	9574.2	2659.5	11.78		378.5	400	81.2					
+2°	13143.6	3651	7.98		352	450	81.2				850	
	11345	3151.4	11		399.1	450	85.2					428.8
	10404.4	2890.1	12.28		428.8	450	81.2					
+4°	13780.1	3827.8	8.71	402.8	500	81.2	850					
	12175.2	3382	11.37	442.8	500	85.2		468.9				
	11123.6	3089.9	12.56	468.9	500	81.2						

外形安装尺寸图 Outline installation dimension drawing

1000QH-40C, 1000QH-50C

1、井筒悬吊式安装
Suspension installation of wellbore

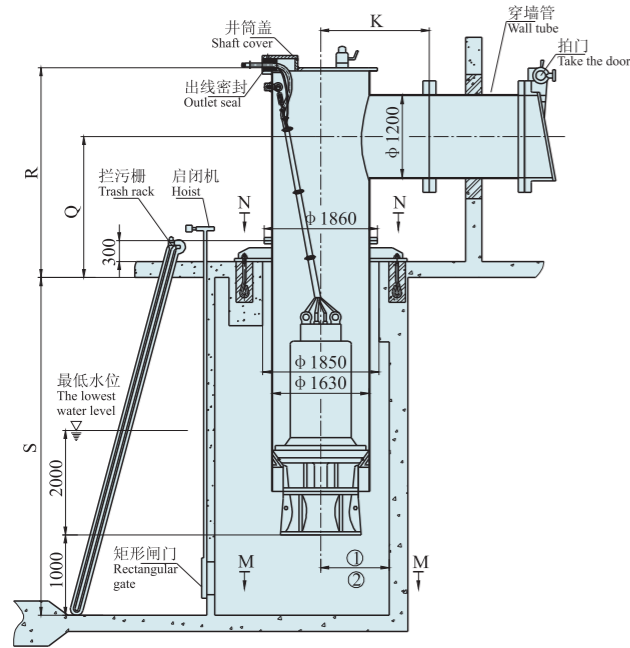

2、混凝土预制井筒式安装
Precast concrete shaft installation

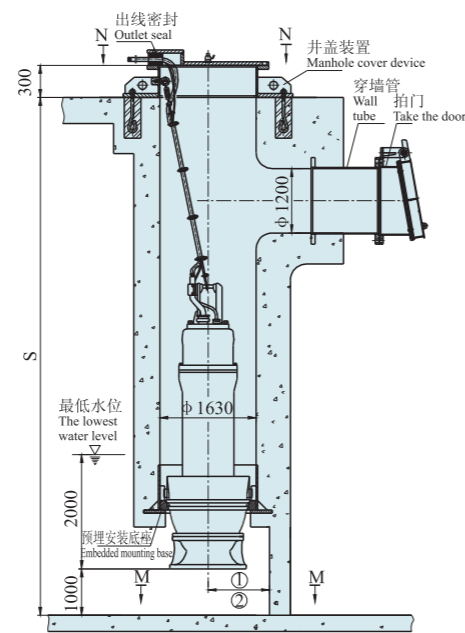

3、弯管悬吊式安装
Bend suspension installation

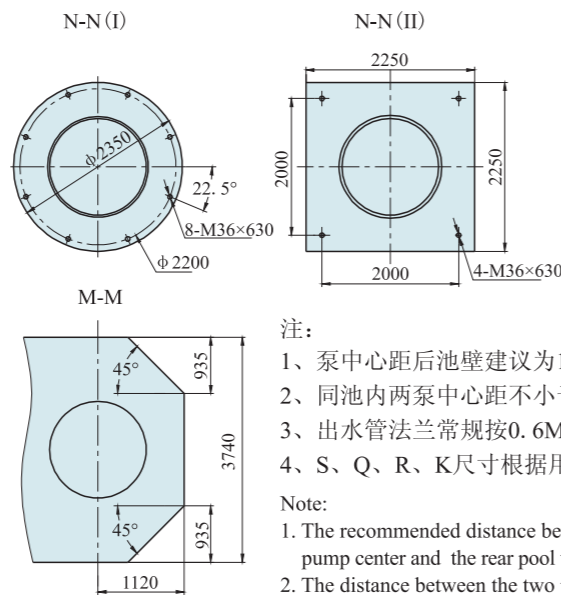
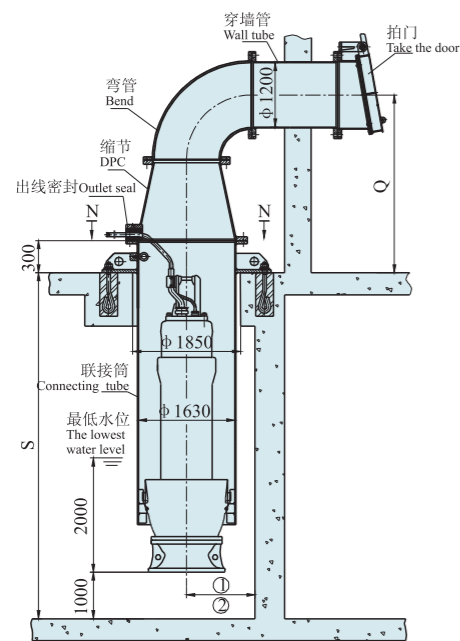

- 注:
- 1、泵中心距后池壁建议为1200;
 - 2、同池内两泵中心距不小于3740;
 - 3、出水管法兰常规按0.6MPa;
 - 4、S、Q、R、K尺寸根据用户要求。

- Note:
1. The recommended distance between the pump center and the rear pool wall is 1200;
 2. The distance between the two pump centers in the same pool shall not be less than 3740;
 3. The outlet pipe flange is normally 0.6mpa;
 4. Sizes of S, Q, R and K are according to user requirements.

QZ、QH型潜水轴流泵、混流泵性能曲线图与性能参数表 Curve and specification

1200QZ-50

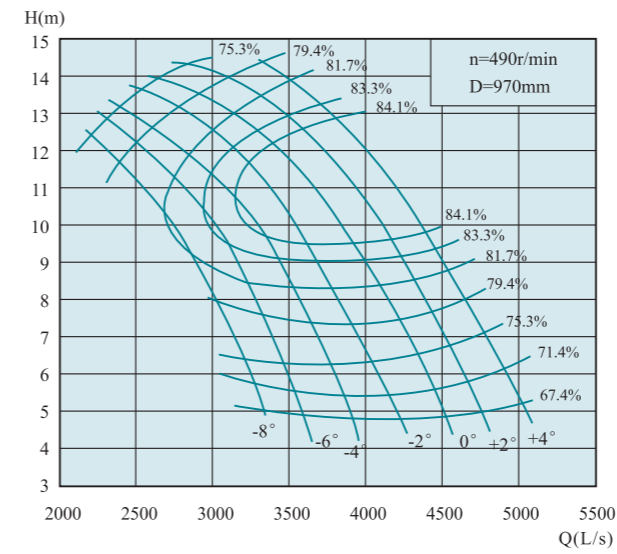

叶片安装角度 Angle	流量Q Capacity		扬程H Head (m)	转速n Speed (r/min)	功率P Power(kw)		效率η Eff. (%)	叶轮直径 Diameter of impeller (mm)
	(m³/h)	(L/s)			轴功率 Shaft power	电机功率 Motor power		
-6°	12572.6	3492.4	5.57	490	267.3	400	71.4	970
	10609.2	2947	10.18		352	400	83.6	
	8399.5	2333.2	12.83		384.9	400	86.3	
-4°	13653.4	3792.6	5.47		285	450	71.4	
	1154.8	3204.1	10.5		389.2	450	84.8	
	8667	2407.5	13.43		415.7	450	76.3	
-2°	14739.5	4094.3	5.47		307.7	500	71.4	
	11882.5	3300.7	10.81		412.8	500	84.8	
	9095	2526.4	13.8		448.3	500	76.3	
0°	15916.7	4421.3	5.73		348.1	560	71.4	
	13198.7	3666.3	10.86		459.5		85	
	10539.7	2927.7	13.61		492.3		79.4	
+2°	16879.7	4688.8	5.86	377.5	71.4			
	13894.2	3859.5	11.13	496.9	84.8			
	11342.2	3150.6	14.06	547.3	79.4			
+4°	17521.6	4867.1	6.36	425.3	71.4			
	14611	4058.6	11.45	537.6	84.8			
	11877.1	3299.2	14.33	584.1	79.4			

1200QZ-70

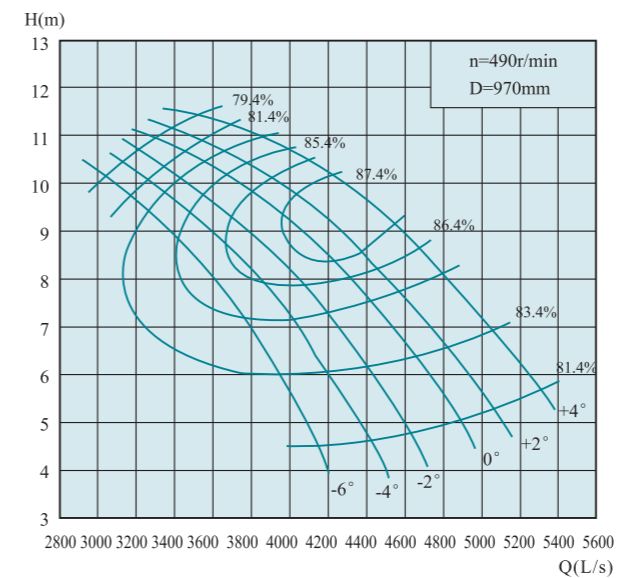

叶片安装角度 Angle	流量Q Capacity		扬程H Head (m)	转速n Speed (r/min)	功率P Power(kw)		效率η Eff. (%)	叶轮直径 Diameter of impeller (mm)	
	(m³/h)	(L/s)			轴功率 Shaft power	电机功率 Motor power			
-6°	1480.3	4112.3	4.48	490	222	400	81.4	970	
	13159.4	3655.4	7.88		330.9	400	85.4		
	10897.6	3027.1	10.15		379.6	400	79.4		
-4°	15832.1	4397.8	4.6		243.8	450	81.4		
	13488.1	3746.7	8.36		354.8		86.6		
	11308.7	3141.3	10.6		411.4		79.4		
-2°	16654.7	4626.3	4.78		266.5		500		81.4
	14187.2	3940.9	8.72		388.4				86.8
	11555.6	3209.9	10.74		425.9				79.4
0°	17477.3	4854.8	5.13		300.1	560			81.4
	14763.2	4100.9	9.1		416.5				87.9
	11843.3	3289.8	11.1		451.2				79.4
+2°	18094	5026.1	5.37	325.3	560		81.4		
	15133.3	4203.7	9.19	429.2			88.3		
	11966.8	3324.1	11.22	460.8			79.4		
+4°	18998.6	5277.4	5.85	372.1		560	81.4		
	15709	4363.6	9.79	479.5			87.4		
	12706.9	3529.7	11.46	499.8			79.4		

QZ、QH型潜水轴流泵、混流泵性能曲线图与性能参数表 Curve and specification

1200QZ-85

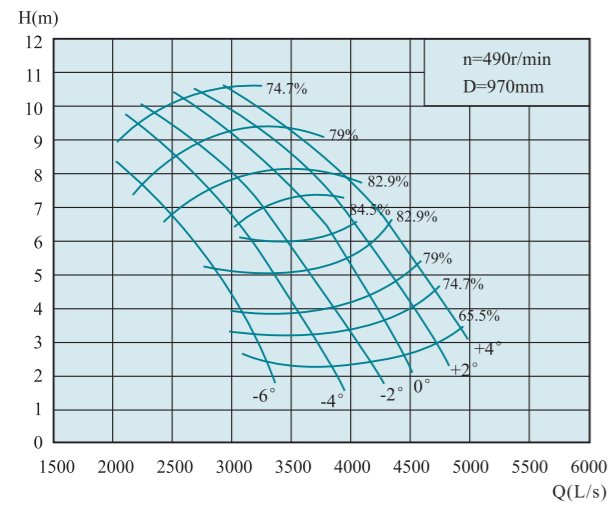

叶片安装角度 Angle	流量Q Capacity		扬程H Head (m)	转速n Speed (r/min)	功率P Power(kw)		效率η Eff. (%)	叶轮直径 Diameter of impeller (mm)
	(m³/h)	(L/s)			轴功率 Shaft power	电机功率 Motor power		
-6°	11144.2	3095.6	3.33	490	135.2	250	74.8	970
	10198.4	2832.9	5.06		167.8		83.8	
	7196.4	1999	8.54		223.9		74.8	
-4°	12912.5	3586.8	3.22		151.5	280	74.8	
	11021	3061.4	6.21		219.9		84.8	
	7895.5	2193.2	9.06		260.6		74.8	
-2°	14516.3	4032.3	3.33		176.1	315	74.8	
	12542.4	3484	6.09		245.5		84.8	
	8676.7	2410.2	9.49		300		74.8	
0°	15626.5	4340.7	3.64		207.2	400	74.8	
	13735.1	3815.3	6.32		275.7		85.8	
	9540.4	2650.1	9.85		342.3		74.8	
+2°	16695.7	4637.7	4.18	254.2	450	74.8		
	14680.8	4078	6.75	318.4		84.8		
	10404	2890	10.14	384.3		74.8		
+4°	17764.9	4934.7	4.69	303.5		74.8		
	15009.8	4169.4	7.63	372.4		83.8		
	11349.7	3152.7	10.12	418.4		74.8		

QZ、QH型潜水轴流泵、混流泵性能曲线图与性能参数表 Curve and specification

1200QZ-125

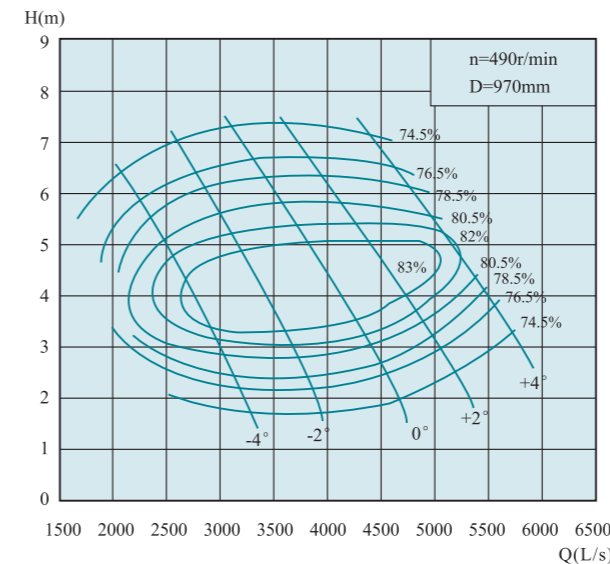

叶片安装角度 Angle	流量Q Capacity		扬程H Head (m)	转速n Speed (r/min)	功率P Power(kw)		效率η Eff. (%)	叶轮直径 Diameter of impeller (mm)
	(m³/h)	(L/s)			轴功率 Shaft power	电机功率 Motor power		
-4°	11185.6	3107.1	2.44	490	94.6	185	78.6	970
	10198.4	2832.9	3.62		121.1		83.1	
	8142.5	2261.8	5.89		170.6		76.6	
-2°	13694	3803.9	2.42		114.9	250	78.6	
	12624.8	3506.9	3.75		154.5		83.5	
	9951.8	2764.4	6.38		225.9		76.6	
0°	16161.1	4489.2	2.72		152.4	315	78.6	
	14886.4	4135.1	4.13		199.2		84.1	
	11966.8	3324.1	6.69		284.8		76.6	
+2°	17970.5	4991.8	3.22		200.6	355	78.6	
	16531.2	4592	4.27		230.4		83.5	
	13858.2	3849.5	6.69		329.8		76.6	
+4°	19615.7	5448.8	4.13	280.9	400	78.6		
	18793.1	5220.3	4.73	294		82.4		
	16778.2	4660.6	6.46	385.6		76.6		

1200QZ-100

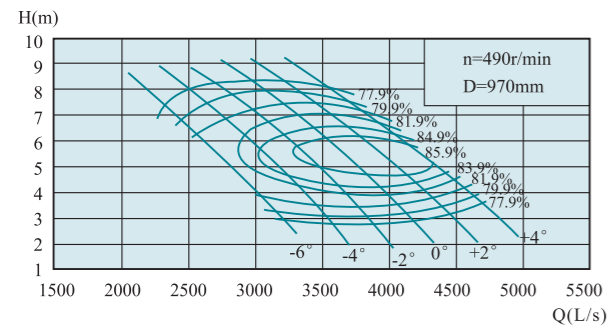

叶片安装角度 Angle	流量Q Capacity		扬程H Head (m)	转速n Speed (r/min)	功率P Power(kw)		效率η Eff. (%)	叶轮直径 Diameter of impeller (mm)
	(m³/h)	(L/s)			轴功率 Shaft power	电机功率 Motor power		
-6°	10938.6	3038.5	3.82	490	139	250	81.9	970
	10280.5	2855.7	4.81		161.4		83.5	
	9252.7	2570.2	6.33		194.9		81.9	
-4°	12501.4	3472.6	3.5		145.6	280	81.9	
	11514.2	3198.4	4.89		180.5		85	
	10054.4	2792.9	6.86		229.5		81.9	
-2°	13611.6	3781	3.4		154	315	81.9	
	12542.4	3484	5.03		200.8		85.6	
	10774.1	2992.8	7.2		258.1		81.9	
0°	14680.8	4078	3.51		171.5	355	81.9	
	13570.6	3769.6	5.01		215.7		85.9	
	11576.2	3215.6	7.46		287.3		81.9	
+2°	15626.5	4340.7	3.78	196.5		81.9		
	14392.8	3998	5.29	240.1		86.4		
	12501.4	3472.6	7.49	311.5		81.9		
+4°	16449.1	4569.2	4.15	227.1		81.9		
	15421	4283.6	5.31	259.2		86.1		
	13776.1	3826.7	7.16	328.2		81.9		

1200QZ-160

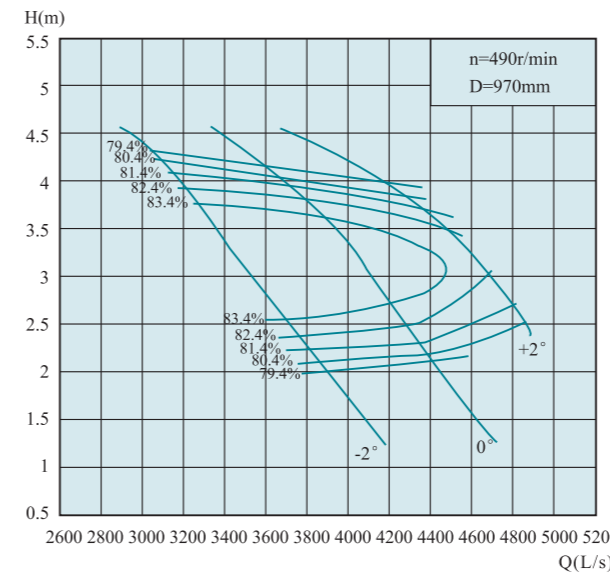

叶片安装角度 Angle	流量Q Capacity		扬程H Head (m)	转速n Speed (r/min)	功率P Power(kw)		效率η Eff. (%)	叶轮直径 Diameter of impeller (mm)
	(m³/h)	(L/s)			轴功率 Shaft power	电机功率 Motor power		
-2°	13925.9	3868.3	2.1	490	99.1	185	80.4	970
	12748	3541.1	2.97		121.5		84.9	
0°	15738.8	4371.9	2.17		115.8	200	80.4	
	14804.3	4112.3	2.98		143.3		83.9	
+2°	17440.6	4844.6	2.51		148.4	220	80.4	
	16531.2	4592	3.22		176		82.4	
	15315.5	4254.3	3.86		200.4		80.4	

QZ、QH型潜水轴流泵、混流泵性能曲线图与性能参数表 Curve and specification

1200QH-40

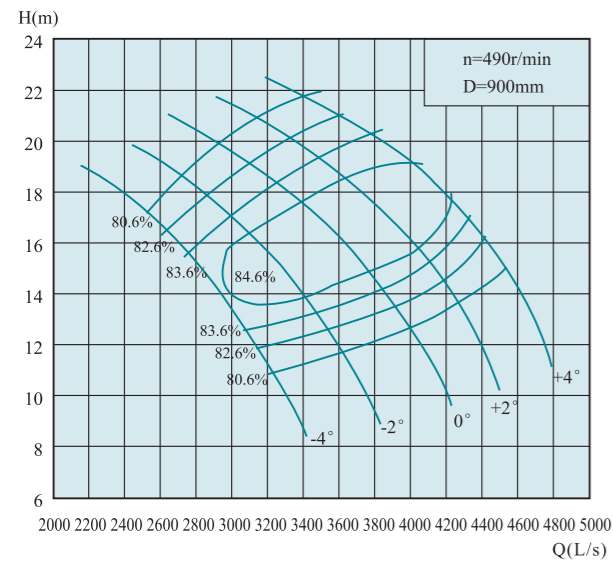

叶片安装角度 Angle	流量Q Capacity		扬程H Head (m)	转速n Speed (r/min)	功率P Power(kw)		效率η Eff. (%)	叶轮直径 Diameter of impeller (mm)
	(m³/h)	(L/s)			轴功率 Shaft power	电机功率 Motor power		
-4°	11660.8	3239.1	10.93	490	430.9	630	80.6	900
	10675.1	2965.3	14.03		483.6	710	84.4	
	9164.2	2545.6	17.37		538.2	80.6		
-2°	13073	3631.4	11.78		520.7	710	80.6	
	11824.9	3284.7	15.21		579.3	80.6		
	9853.9	2737.2	18.74		624.3	80.6		
0°	14353.9	3987.2	12.71		616.8	800	80.6	
	12810.2	3558.4	16.55		680.5	80.6		
	10609.6	2947.1	20.11		721.3	80.6		
+2°	15405.1	4279.2	13.75		716.1	900	80.6	
	13795.6	3832.1	17.47		767.2	85.6		
	11332.1	3147.8	21.12		809.2	80.6		
+4°	16324.9	4534.7	15.16	836.7	1000	80.6		
	14781.2	4105.9	18.71	885.6	85.1			
	12317.8	3421.6	21.97	914.9	80.6			

1200QH-50

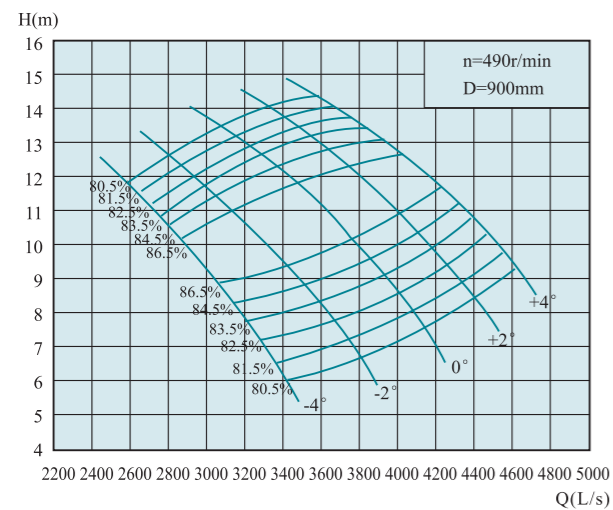

叶片安装角度 Angle	流量Q Capacity		扬程H Head (m)	转速n Speed (r/min)	功率P Power(kw)		效率η Eff. (%)	叶轮直径 Diameter of impeller (mm)
	(m³/h)	(L/s)			轴功率 Shaft power	电机功率 Motor power		
-4°	12120.5	3366.8	6.53	490	264.3	400	81.6	900
	10510.9	2919.7	9.97		333.6	450	85.6	
	9492.8	2636.9	11.56		366.5	81.6		
-2°	13467.2	3740.9	7.19		323.4	450	81.6	
	11496.2	3193.4	10.79		394.4	85.7		
	10314	2865	12.33		424.7	81.6		
0°	14682.6	4078.5	8.02		393.2	560	81.6	
	12810.2	3558.4	11.31		461.2	85.6		
	11365.2	3157	13.21		501.4	81.6		
+2°	15602.4	4334	8.94		465.8	630	81.6	
	13467.2	3740.9	12.33		528.6	85.6		
	12350.5	3430.7	13.77		567.9	81.6		
+4°	16357.7	4543.8	9.76	533.1	710	81.6		
	14452.6	4014.6	12.74	586.1	85.6			
	13204.4	3667.9	14.08	620.9	81.6			

外形安装尺寸图 Outline installation dimension drawing

1200QZ-50, 1200QZ-70, 1200QZ-85, 1200QZ-100, 1200QZ-125, 1200QZ-160
1200QH-40, 1200QH-50

1、井筒悬吊式安装
Suspension installation of wellbore

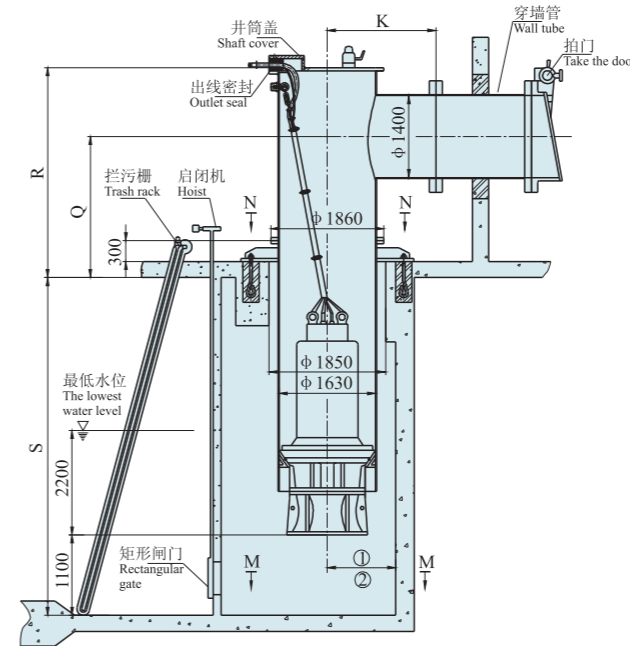

2、混凝土预制井筒式安装
Precast concrete shaft installation

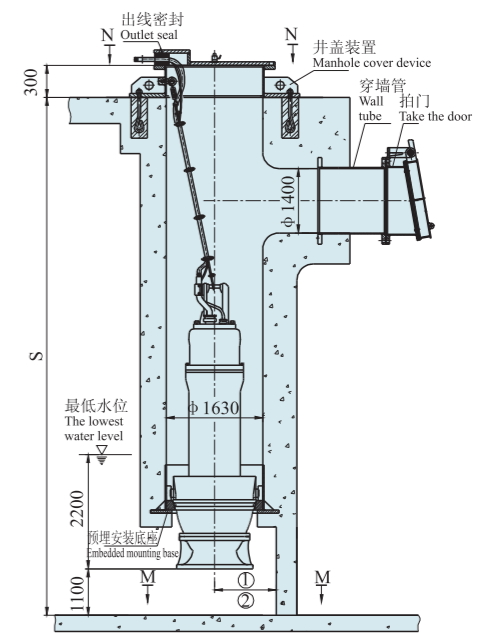

3、弯管悬吊式安装
Bend suspension installation

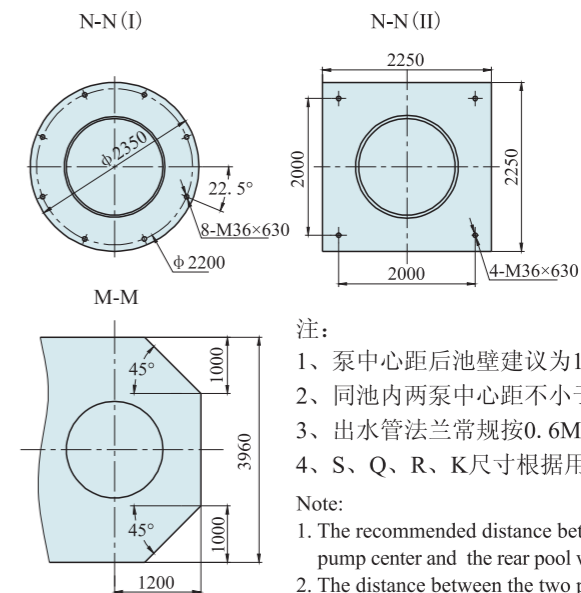
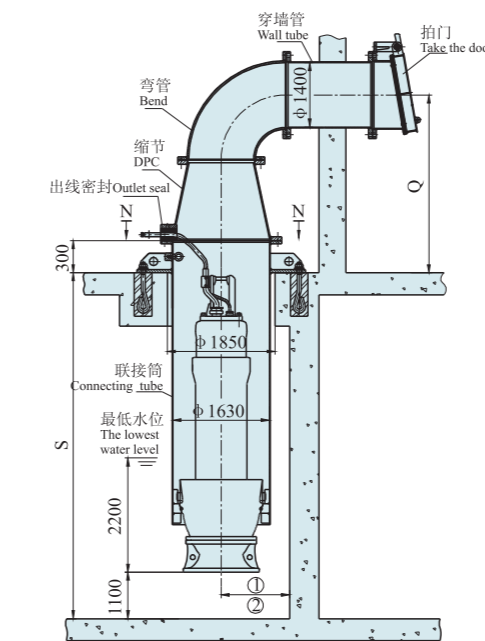

- 注：
1、泵中心距后池壁建议为1200；
2、同池内两泵中心距不小于3960；
3、出水管法兰常规按0.6MPa；
4、S、Q、R、K尺寸根据用户要求。
- Note:
1. The recommended distance between the pump center and the rear pool wall is 1200;
2. The distance between the two pump centers in the same pool shall not be less than 3960;
3. The outlet pipe flange is normally 0.6mpa;
4. Sizes of S, Q, R and K are according to user requirements.

QZ、QH型潜水轴流泵、混流泵性能曲线图与性能参数表 Curve and specification

1400QZ-50

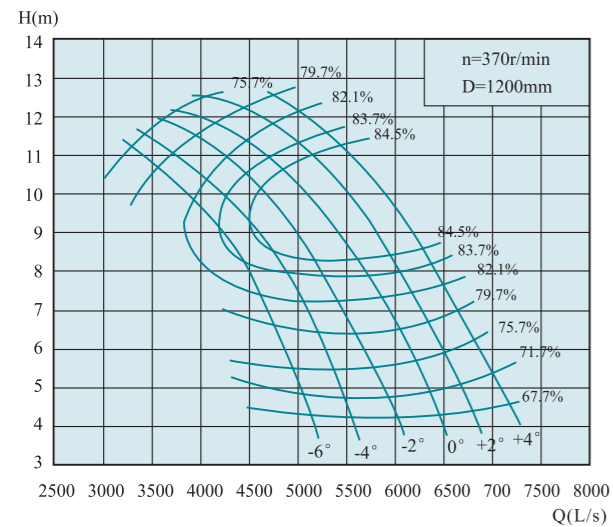

叶片安装角度 Angle	流量Q Capacity		扬程H Head (m)	转速n Speed (r/min)	功率P Power(kw)		效率η Eff. (%)	叶轮直径 Diameter of impeller (mm)
	(m³/h)	(L/s)			轴功率 Shaft power	电机功率 Motor power		
-6°	17974.8	4993	4.86	370	331.5	560	71.8	1200
	15167.5	4213.2	8.89		437.4			
	12008.5	3335.7	11.19		477.4			
-4°	19519.9	5422.2	4.77		353.4			
	16490.9	4580.8	9.16		483.1			
	12391.2	3442	11.72		516			
-2°	21072.6	5853.5	4.77		381.5	630	71.8	
	16988	4718.9	9.43		512.4			
	13002.8	3611.9	12.05		556.7			
0°	22755.2	6320.9	5		431.8			
	18869.8	5241.6	9.48		570.8			
	15068.2	4185.6	11.88		611.3			
+2°	24132.2	6703.4	5.11	468	800	71.8		
	19864.1	5517.8	9.72	617.5				
	16215.5	4504.3	12.27	679.4				
+4°	25049.9	6958.3	5.55	527.6				
	20889	5802.5	9.99	667.4				
	16980.5	4716.8	12.5	724.8				

1400QZ-70

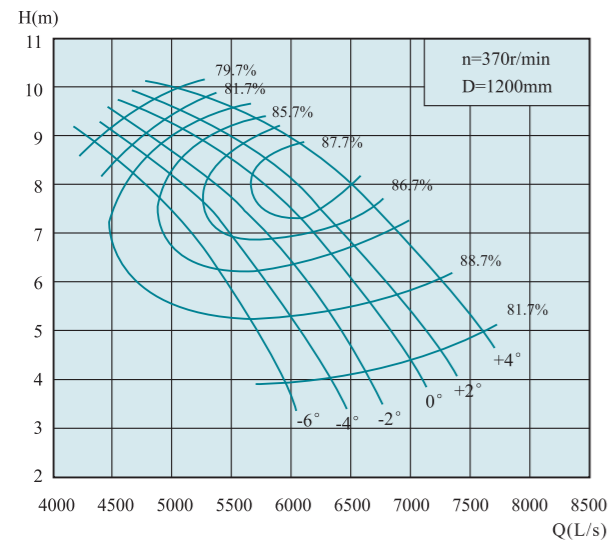

叶片安装角度 Angle	流量Q Capacity		扬程H Head (m)	转速n Speed (r/min)	功率P Power(kw)		效率η Eff. (%)	叶轮直径 Diameter of impeller (mm)
	(m³/h)	(L/s)			轴功率 Shaft power	电机功率 Motor power		
-6°	21165.1	5879.2	3.91	370	276	500	81.7	1200
	18813.2	5225.9	6.88		411.6			
	15579.7	4327.7	8.86		472			
-4°	22634.6	6287.4	4.01		302.7			
	19283.8	5356.6	7.29		440.8			
	16167.6	4491	9.25		511.3			
-2°	23810.8	6614.1	4.17		331.2	560	81.7	
	20283.1	5634.2	7.61		482.9			
	16520.4	4589	9.38		529.8			
0°	24986.5	6940.7	4.48		373.4			
	21106.1	5862.8	7.94		517.8			
	16931.9	4703.3	9.69		561			
+2°	25868.5	7185.7	4.69	404.7	630	81.7		
	21635.3	6009.8	8.02	533.7				
	17108.3	4752.3	9.79	572.7				
+4°	27161.6	7544.9	5.1	462				
	22458.6	6238.5	8.54	595.9				
	18166.7	5046.3	10	621.1				

QZ、QH型潜水轴流泵、混流泵性能曲线图与性能参数表 Curve and specification

1400QZ-85

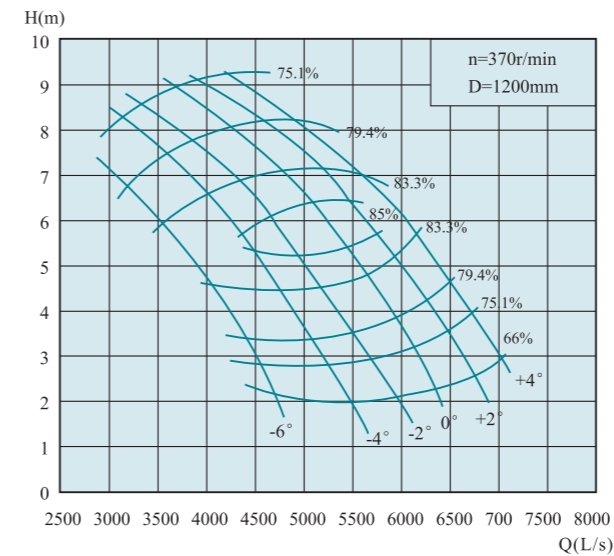

叶片安装角度 Angle	流量Q Capacity		扬程H Head (m)	转速n Speed (r/min)	功率P Power(kw)		效率η Eff. (%)	叶轮直径 Diameter of impeller (mm)
	(m³/h)	(L/s)			轴功率 Shaft power	电机功率 Motor power		
-6°	15932.5	4425.7	2.91	370	168	315	75.2	1200
	14580.4	4050.1	4.42		208.6			
	10288.4	2857.9	7.45		277.8			
-4°	18460.4	5127.9	2.81		188			
	15756.1	4376.7	5.42		273.1			
	11288.2	3135.6	7.91		323.6			
-2°	20753.6	5764.9	2.91		218.8	400	75.2	
	17931.6	4981	5.31		304.5			
	12404.9	3445.8	8.28		372.2			
0°	22340.9	6205.8	3.18		257.4			
	19636.6	5454.6	5.51		342			
	13639.7	3788.8	8.59		424.6			
+2°	23869.4	6630.4	3.65	315.7	560	75.2		
	20988.7	5830.2	5.89	395.4				
	14874.5	4131.8	8.84	476.5				
+4°	25398	7055	4.09	376.4				
	21458.9	5960.8	6.66	462.5				
	16226.6	4507.4	8.83	519.2				

1400QZ-100

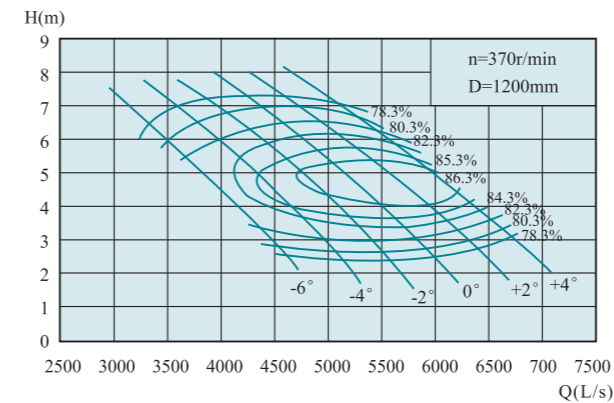

叶片安装角度 Angle	流量Q Capacity		扬程H Head (m)	转速n Speed (r/min)	功率P Power(kw)		效率η Eff. (%)	叶轮直径 Diameter of impeller (mm)
	(m³/h)	(L/s)			轴功率 Shaft power	电机功率 Motor power		
-6°	15638.8	4344.1	3.33	370	172.4	315	82.3	1200
	14698.1	4082.8	4.2		200.5			
	13228.2	3674.5	5.52		241.8			
-4°	17872.6	4964.6	3.05		180.5			
	16461.7	4572.7	4.27		224.3			
	14374.4	3992.9	5.99		285.1			
-2°	19460.2	5405.6	2.97		191.4	355	82.3	
	17931.6	4981	4.39		249.4			
	15403.3	4278.7	6.28		320.3			
0°	20988.7	5830.2	3.06		212.7			
	19401.1	5389.2	4.38		268.3			
	16549.9	4597.2	6.51		356.7			
+2°	22340.9	6205.8	3.3	244.1	400	82.3		
	20577.2	5715.9	4.62	298.5				
	17872.6	4964.6	6.53	386.4				
+4°	23516.6	6532.4	3.63	282.6				
	22046.8	6124.1	4.64	322.3				
	19695.2	5470.9	6.25	407.6				

QZ、QH型潜水轴流泵、混流泵性能曲线图与性能参数表 Curve and specification

1400QZ-125

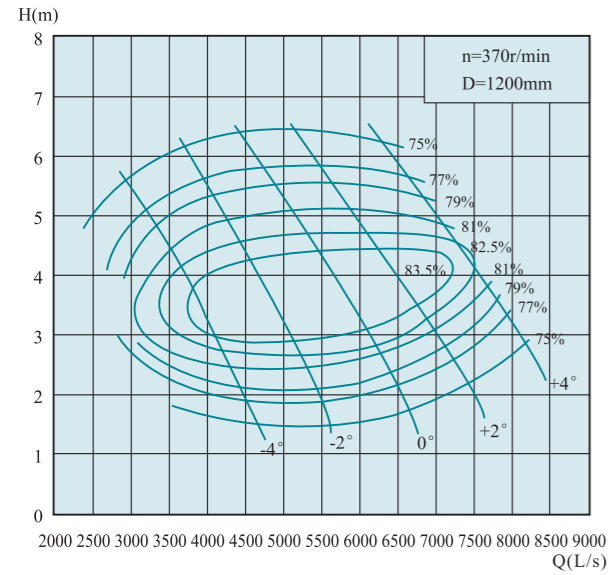

叶片安装角度 Angle	流量Q Capacity		扬程H Head (m)	转速n Speed (r/min)	功率P Power(kw)		效率η Eff. (%)	叶轮直径 Diameter of impeller (mm)	
	(m³/h)	(L/s)			轴功率 Shaft power	电机功率 Motor power			
-4°	15991.2	4442	2.13	370	117.5	250	79	1200	
	14580.4	4050.1	3.16		150.4		83.5		
	11640.6	3233.5	5.14		211.7		77		
-2°	19577.5	5438.2	2.11		142.5	315	79		
	18049	5013.6	3.27		191.7		83.9		
	14227.6	3952.1	5.56		280		77		
0°	23105.2	6418.1	2.38		189.7	400	79		
	21282.5	5911.8	3.6		247.1		84.5		
	17108.3	4752.3	5.83		353		77		
+2°	25692.1	7136.7	2.81		249	400	79		
	23634.4	6565.1	3.73		286.3		83.9		
	20170	5603.6	5.53		381.6		78		
+4°	28043.6	7789.9	3.6	348.2	500	79			
	26867.9	7463.3	4.13	365.2		82.8			
	23987.2	6753.1	5.54	460.8		78			

1400QZ-160

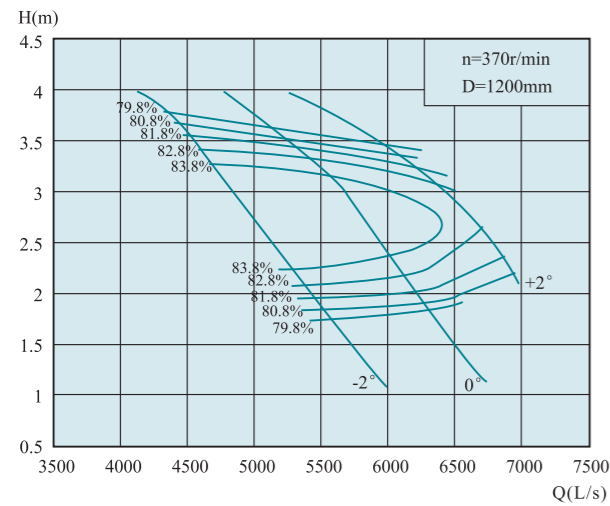

叶片安装角度 Angle	流量Q Capacity		扬程H Head (m)	转速n Speed (r/min)	功率P Power(kw)		效率η Eff. (%)	叶轮直径 Diameter of impeller (mm)	
	(m³/h)	(L/s)			轴功率 Shaft power	电机功率 Motor power			
-2°	19909.1	5530.3	1.83	370	122.9	220	76	1200	
	18225.4	5062.6	2.59		150.8		80.5		
	15960.6	4433.5	3.68		198.1		76		
0°	22501.4	6250.4	1.9		144.2	250	76		
	21165.1	5879.2	2.6		177.9		79.5		
	18853.2	5237	3.52		223.8		76		
+2°	24934.3	6926.2	2.19		184.2	280	76		
	23634.4	6565.1	2.81		218.6		78		
	21895.9	6082.2	3.37		248.9		76		

QZ、QH型潜水轴流泵、混流泵性能曲线图与性能参数表 Curve and specification

1300QH-50

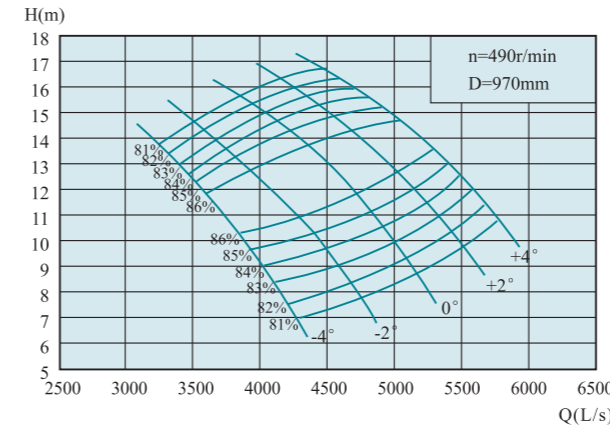

叶片安装角度 Angle	流量Q Capacity		扬程H Head (m)	转速n Speed (r/min)	功率P Power(kw)		效率η Eff. (%)	叶轮直径 Diameter of impeller (mm)	
	(m³/h)	(L/s)			轴功率 Shaft power	电机功率 Motor power			
-4°	15174.4	4215.1	7.58	490	382.2	560	82	970	
	13159.4	3655.4	11.58		482.9		86		
	11884.3	3301.2	13.43		530.4		82		
-2°	16860.2	4683.4	8.36		468.4	630	82		
	14392.8	3998	12.54		571.2		86.1		
	12912.5	3586.8	14.33		614.9		82		
0°	18382	5106.1	9.31		568.7	800	82		
	16038	4455	13.13		667.2		86		
	14228.6	3952.4	15.34		725.3		82		
+2°	19533.2	5425.9	10.39		674.4	900	82		
	16860.2	4683.4	14.33		765.6		86		
	15462	4295	16		822.1		82		
+4°	20479	5688.6	11.34	771.7	1000	82			
	18094	5026.1	14.8	848.5		86			
	16531.2	4592	16.36	898.8		82			

1400QH-50

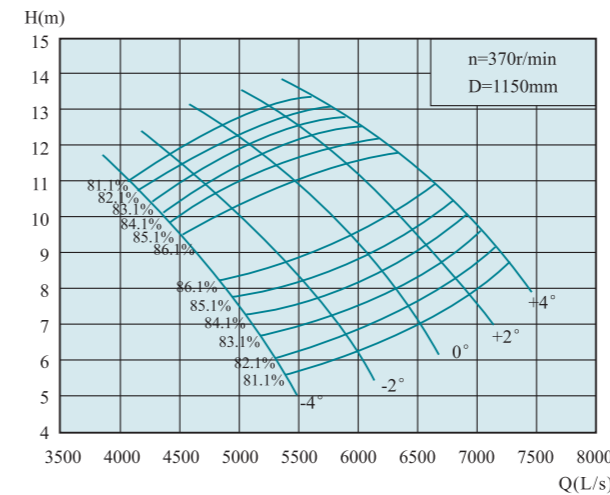

叶片安装角度 Angle	流量Q Capacity		扬程H Head (m)	转速n Speed (r/min)	功率P Power(kw)		效率η Eff. (%)	叶轮直径 Diameter of impeller (mm)	
	(m³/h)	(L/s)			轴功率 Shaft power	电机功率 Motor power			
-4°	19093.7	5303.8	6.08	370	384.8	560	82.2	1150	
	16558.2	4599.5	9.28		485.8		86.2		
	14954.4	4154	10.76		533.4		82.2		
-2°	21215.2	5893.1	6.7		471.2	710	82.2		
	18110.5	5030.7	10.05		574.7		86..		
	16247.9	4513.3	11.48		618.3		82.2		
0°	23130	6425	7.46		572	800	82.2		
	20180.5	5605.7	10.52		671.1		86.2		
	17903.5	4973.2	12.29		729.4		82.2		
+2°	24578.6	6827.4	8.32		677.9	900	82.2		
	21215.2	5893.1	11.48		769.9		86.2		
	19455.8	5404.4	12.82		826.9		82.2		
+4°	25768.8	7158	9.09	776.5	1000	82.2			
	22767.8	6324.4	11.86	853.6		86.2			
	20801.5	5778.2	13.11	904.1		82.2			

外形安装尺寸图 Outline installation dimension drawing

1400QZ-50, 1400QZ-70, 1400QZ-85, 1400QZ-100, 1400QZ-125, 1400QZ-160
1300QH-50, 1400QH-50

1、井筒悬吊式安装
Suspension installation of wellbore

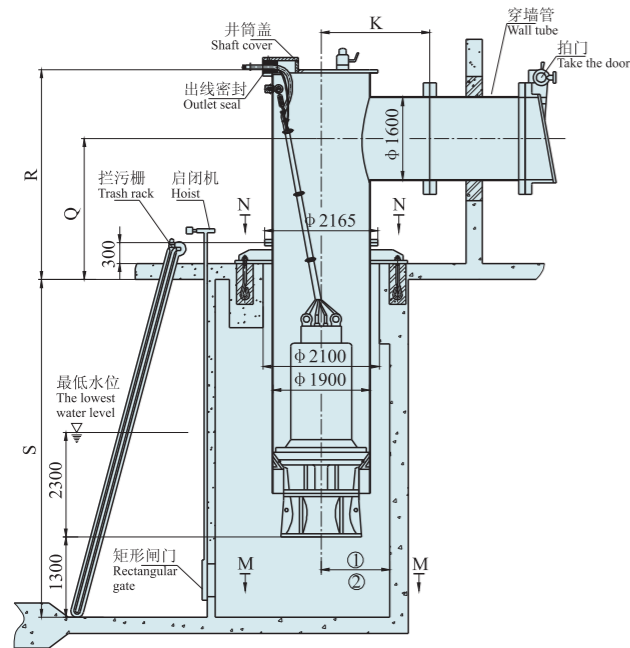

2、混凝土预制井筒式安装
Precast concrete shaft installation

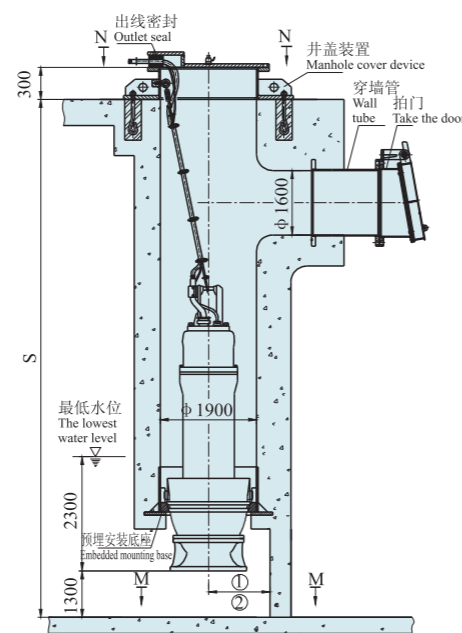

3、弯管悬吊式安装
Bend suspension installation

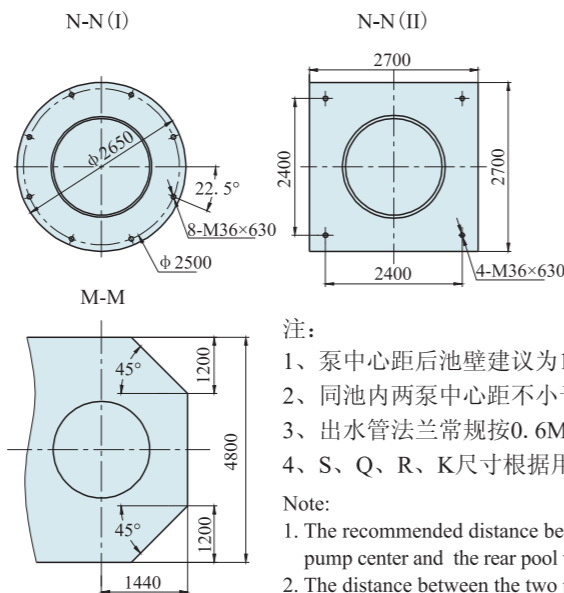
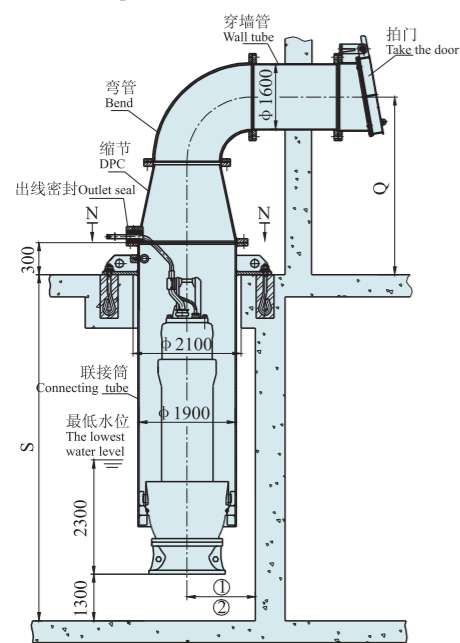

- 注:
- 1、泵中心距后池壁建议为1440;
 - 2、同池内两泵中心距不小于4800;
 - 3、出水管法兰常规按0.6MPa;
 - 4、S、Q、R、K尺寸根据用户要求。

- Note:
1. The recommended distance between the pump center and the rear pool wall is 1440;
 2. The distance between the two pump centers in the same pool shall not be less than 4800;
 3. The outlet pipe flange is normally 0.6mpa;
 4. Sizes of S, Q, R and K are according to user requirements.

QZ、QH型潜水轴流泵、混流泵性能曲线图与性能参数表 Curve and specification

1600QZ-70

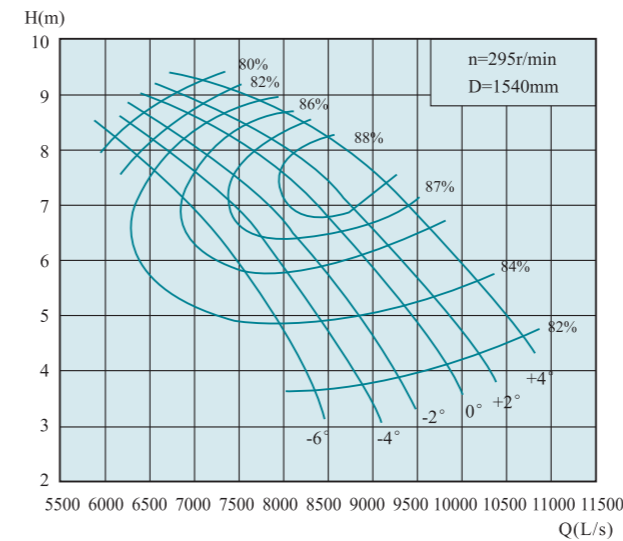

叶片安装角度 Angle	流量Q Capacity		扬程H Head (m)	转速n Speed (r/min)	功率P Power(kw)		效率η Eff. (%)	叶轮直径 Diameter of impeller (mm)
	(m³/h)	(L/s)			轴功率 Shaft power	电机功率 Motor power		
-6°	29771.3	8269.8	3.63	295	359.1	630	82	1450
	26463.6	7351	6.38		535	710	86	
	21915	6087.5	8.22		613.6	80	80	
-4°	31838.8	8844.1	3.72		393.6	710	82	
	27124.9	7534.7	6.77		573.9	80	87.2	
	22741.9	6317.2	8.59		665.4	80	80	
-2°	33493	9303.6	3.87		430.7	800	82	
	28531.1	7925.3	7.06		628		87.4	
	23238.4	6455.1	8.7		688.7		80	
0°	35146.8	9763	4.16		485.9		82	
	29688.8	8246.9	7.37		673.7		88.5	
	23817.2	6615.9	8.99		729.3		80	
+2°	36387.4	10107.6	4.35	526	900	82		
	30433	8453.6	7.45	695		88.9		
	24065.3	6684.8	9.09	745.1		80		
+4°	38206.8	10613	4.74	601.8	80	82		
	31590.7	8775.2	7.93	775.7		88		
	25553.9	7098.3	9.28	807.8	80	80		

1600QZ-85

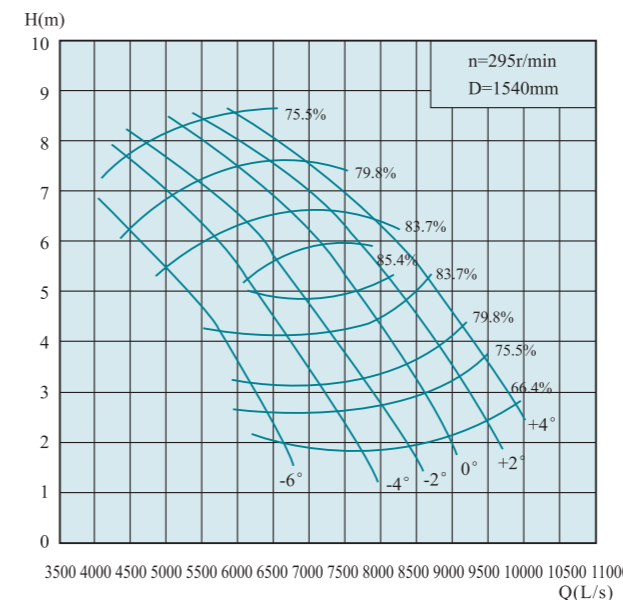

叶片安装角度 Angle	流量Q Capacity		扬程H Head (m)	转速n Speed (r/min)	功率P Power(kw)		效率η Eff. (%)	叶轮直径 Diameter of impeller (mm)	
	(m³/h)	(L/s)			轴功率 Shaft power	电机功率 Motor power			
-6°	22411.1	6225.3	2.7	295	28.1	400	75.6	1450	
	20509.2	5697	4.1		270.8	450	84.6		
	14472.4	4020.1	6.91		360.5	75.6			
-4°	25967.2	7213.1	2.61		244.3	560	75.6		
	22163	6156.4	5.03		354.9		85.6		
	15878.2	4410.6	7.34		420.1		75.6		
-2°	29192.4	8109	2.7		284.1		630		75.6
	25223	7006.4	4.93		395.9				85.6
	17449.2	4847	7.69		483.7				75.6
0°	31425.5	8729.3	2.95		334.2	710	75.6		
	27621.4	7672.6	5.12		445		86.6		
	19185.8	5329.4	7.98		551.9		75.6		
+2°	33575.4	9326.5	3.38	409.1	8.2	75.6			
	29523.2	8200.9	5.46	513.2		85.6			
	20922.8	5811.9	8.21	619.2		75.6			
+4°	35725.7	9923.8	3.8	489.3	8.2	75.6			
	30184.9	8384.7	6.18	600.9		84.6			
	22824.7	6340.2	8.2	674.6	75.6	75.6			

QZ、QH型潜水轴流泵、混流泵性能曲线图与性能参数表 Curve and specification

1600QZ-100

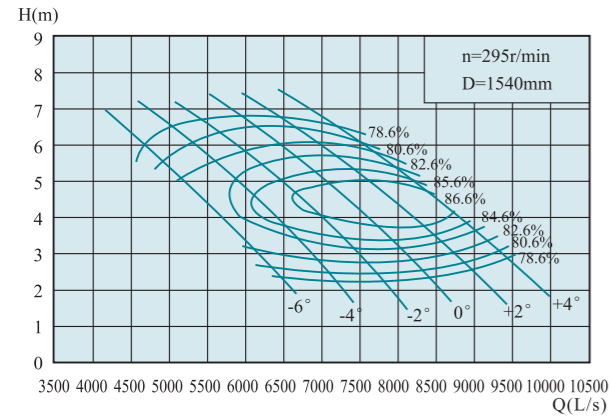

叶片安装角度 Angle	流量Q Capacity		扬程H Head (m)	转速n Speed (r/min)	功率P Power(kw)		效率η Eff. (%)	叶轮直径 Diameter of impeller (mm)
	(m³/h)	(L/s)			轴功率 Shaft power	电机功率 Motor power		
-6°	21997.8	6110.5	3.09	295	224	355	82.7	1450
	20674.4	5742.9	3.9		260.6		84.3	
	18607	5168.6	5.12		313.9		82.7	
-4°	25140.2	6983.4	2.83		234.4	400	82.7	
	23155.6	6432.1	3.96		291.2		85.8	
	20219.8	5616.6	5.56		370.4		82.7	
-2°	27373.3	7603.7	2.76		248.9	450	82.7	
	25223	7006.4	4.07		323.9		86.4	
	21667	6018.6	5.83		416.2		82.7	
0°	29523.2	8200.9	2.84		276.3	500	82.7	
	27290.5	7580.7	4.06		348.2		86.7	
	23279.8	6466.6	6.04		463.3		82.7	
+2°	31425.5	8729.3	3.07	317.9	560	82.7		
	28944.4	8040.1	4.28	387.1		87.2		
	25140.2	6983.4	6.06	502		82.7		
+4°	33079.3	9188.7	3.36	366.2	560	82.7		
	31011.8	8614.4	4.3	418.2		86.9		
	27703.8	7695.5	5.8	529.5		82.7		

QZ、QH型潜水轴流泵、混流泵性能曲线图与性能参数表 Curve and specification

1600QZ-160

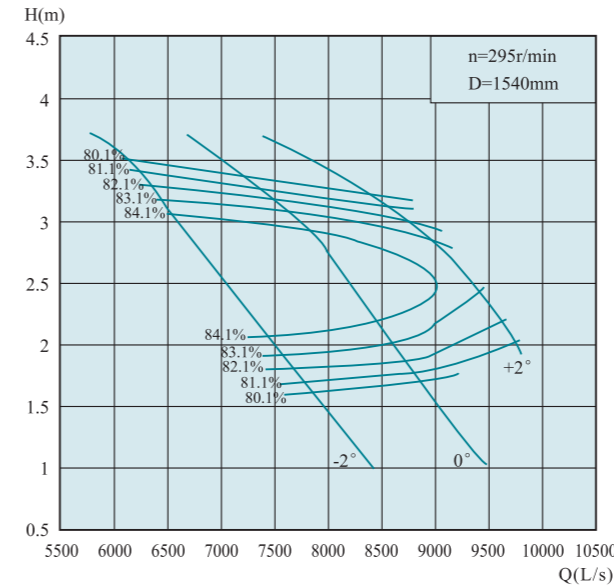

叶片安装角度 Angle	流量Q Capacity		扬程H Head (m)	转速n Speed (r/min)	功率P Power(kw)		效率η Eff. (%)	叶轮直径 Diameter of impeller (mm)
	(m³/h)	(L/s)			轴功率 Shaft power	电机功率 Motor power		
-2°	28005.1	7779.2	1.7	295	159.8	280	81.2	1450
	25636.3	7121.2	2.41		196.5		85.7	
	22451	6236.4	3.41		256.9		81.2	
0°	31651.2	8792	1.76		186.9	315	81.2	
	29771.3	8269.8	2.42		231.8		84.7	
	26519.8	7366.6	3.27		291		81.2	
+2°	35073.4	9742.6	2.03		238.9	355	81.2	
	33244.6	9234.6	2.61		284.2		83.2	
	30799.4	8555.4	3.12		322.5		81.2	

1600QZ-125

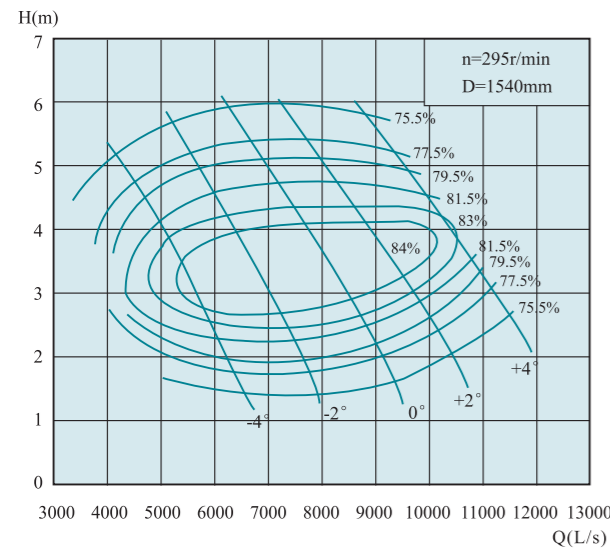

叶片安装角度 Angle	流量Q Capacity		扬程H Head (m)	转速n Speed (r/min)	功率P Power(kw)		效率η Eff. (%)	叶轮直径 Diameter of impeller (mm)
	(m³/h)	(L/s)			轴功率 Shaft power	电机功率 Motor power		
-4°	22493.9	6248.3	1.97	295	151.9	315	79.5	1450
	20509.2	5697	2.93		194.9		84	
	16374.2	4548.4	4.77		274.6		77.5	
-2°	27538.6	7649.6	1.96		185	400	79.5	
	25388.3	7052.3	3.04		249.2		84.4	
	20013.1	5559.2	5.16		363.1		77.5	
0°	32500.4	9027.9	2.2		245.1	500	79.5	
	29936.9	8315.8	3.35		321.5		85	
	24065.3	6684.8	5.41		457.8		77.5	
+2°	36139.3	10038.7	2.61		323.3	560	79.5	
	33244.6	9234.6	3.46		371.4		84.4	
	27869.4	7741.5	5.41		530.1		77.5	
+4°	39447	10957.5	3.35	453	710	79.5		
	37793.2	10498.1	3.83	473.5		83.3		
	33741	9372.5	5.23	620.5		77.5		

1600QZ-70C

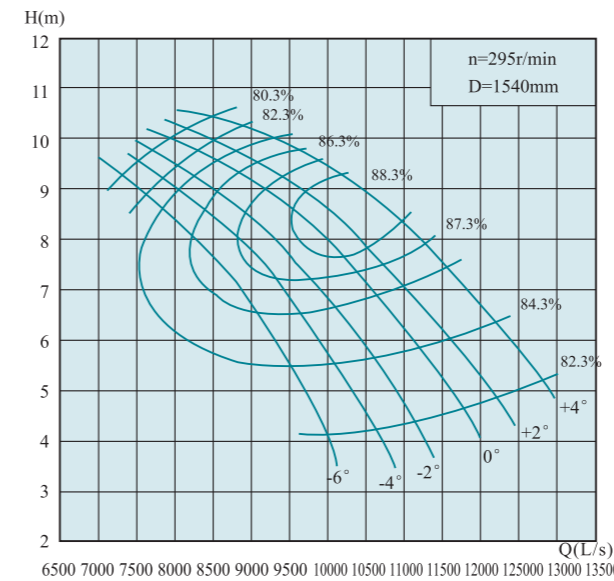

叶片安装角度 Angle	流量Q Capacity		扬程H Head (m)	转速n Speed (r/min)	功率P Power(kw)		效率η Eff. (%)	叶轮直径 Diameter of impeller (mm)
	(m³/h)	(L/s)			轴功率 Shaft power	电机功率 Motor power		
-6°	35666.3	9907.3	4.09	295	483	900	82.3	1540
	31703.4	8806.5	7.2		720.8		86.3	
	26254.4	7292.9	9.27		825.9		80.3	
-4°	38143.1	10595.3	4.2		530.4	1000	82.3	
	32495.8	9026.6	7.63		772.2		87.5	
	27245.2	7568.1	9.69		895.9		80.3	
-2°	40124.5	11145.7	4.36		579.2	1100	82.3	
	34180.2	9494.5	7.96		845.4		87.7	
	27839.5	7733.2	9.82		927.7		80.3	
0°	42106	11696.1	4.69		653.9	1200	82.3	
	35567.3	9879.8	8.31		907		88.8	
	28532.9	7925.8	10.14		981.8		80.3	
+2°	43592	12108.9	4.91	708.7	1200	82.3		
	36459	10127.5	8.4	935.6		89.2		
	28830.2	8008.4	10.25	1002.8		80.3		
+4°	45771.8	12714.4	5.34	809.3	1200	82.3		
	37845.7	10512.7	8.94	1044.1		88.3		
	30613.7	8503.8	10.47	1087.7		80.3		

QZ、QH型潜水轴流泵、混流泵性能曲线图与性能参数表 Curve and specification

1600QZ-85C

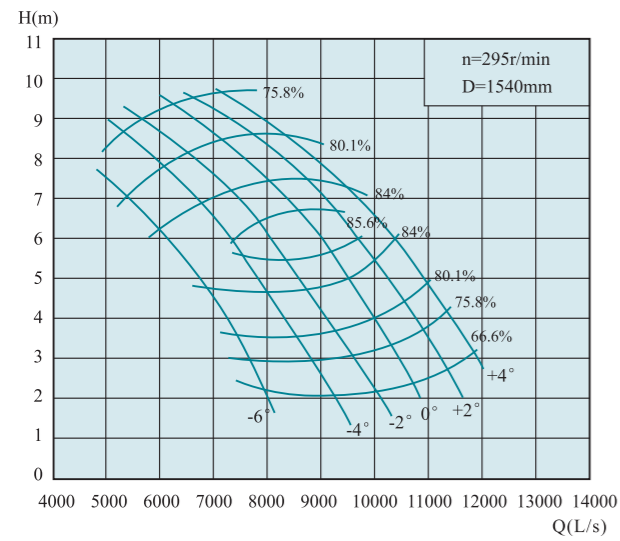

叶片安装角度 Angle	流量Q Capacity		扬程H Head (m)	转速n Speed (r/min)	功率P Power(kw)		效率η Eff. (%)	叶轮直径 Diameter of impeller (mm)
	(m³/h)	(L/s)			轴功率 Shaft power	电机功率 Motor power		
-6°	26848.8	7458	3.04	295	293	560	75.9	1540
	24570	6825	4.62		364.3		84.9	
	17337.6	4816	7.8		485.5		75.9	
-4°	31109	8641.4	2.94		328.4	630	75.9	
	26551.4	7375.4	5.67		477.6		85.9	
	19022	5283.9	8.28		565.5		75.9	
-2°	34972.6	9714.6	3.04		381.7	710	75.9	
	30217.3	8393.7	5.56		533		85.9	
	20904.5	5806.8	8.67		650.7		75.9	
0°	37647.7	10457.7	3.33		450.1	800	75.9	
	33090.5	9191.8	5.77		598.7		86.9	
	22984.9	6384.7	9		742.7		75.9	
+2°	40223.5	11173.2	3.82	551.7	900	75.9		
	35368.9	9824.7	6.16	691.2		85.9		
	25065.4	696.6	9.26	833.3		75.9		
+4°	42799.3	11888.7	4.29	659.2	1000	75.9		
	36161.6	10044.9	6.97	809		84.9		
	27344.2	7595.6	9.25	908.1		75.9		

1600QZ-100C

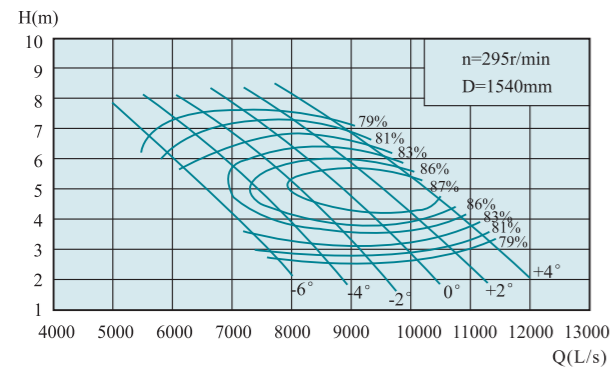

叶片安装角度 Angle	流量Q Capacity		扬程H Head (m)	转速n Speed (r/min)	功率P Power(kw)		效率η Eff. (%)	叶轮直径 Diameter of impeller (mm)
	(m³/h)	(L/s)			轴功率 Shaft power	电机功率 Motor power		
-6°	26353.4	7320.4	3.49	295	302	450	83	1540
	24768.4	6880.1	4.4		351		84.6	
	22291.6	6192.1	5.78		423		83	
-4°	30118.3	8366.2	3.2		316.4	560	83	
	27740.5	7705.7	4.47		392.5		86.1	
	24223.3	6728.7	6.27		498.6		83	
-2°	32793.1	9109.2	3.11		334.8	630	83	
	30217.3	8393.7	4.59		435.9		86.7	
	25957.1	7210.3	6.58		560.8		83	
0°	35368.9	9824.7	3.21		372.7	710	83	
	32694.1	9081.7	4.58		469		87	
	27889.2	7747	6.82		624.5		83	
+2°	37647.7	10457.7	3.46	427.7	800	83		
	34675.6	9632.1	4.83	521.6		87.5		
	30118.3	8366.2	6.84	676.4		83		
+4°	39629.2	11008.1	3.8	494.4	800	83		
	37152.4	10320.1	4.85	563.1		87.2		
	33189.5	9219.3	6.54	712.6		83		

QZ、QH型潜水轴流泵、混流泵性能曲线图与性能参数表 Curve and specification

1600QZ-125C

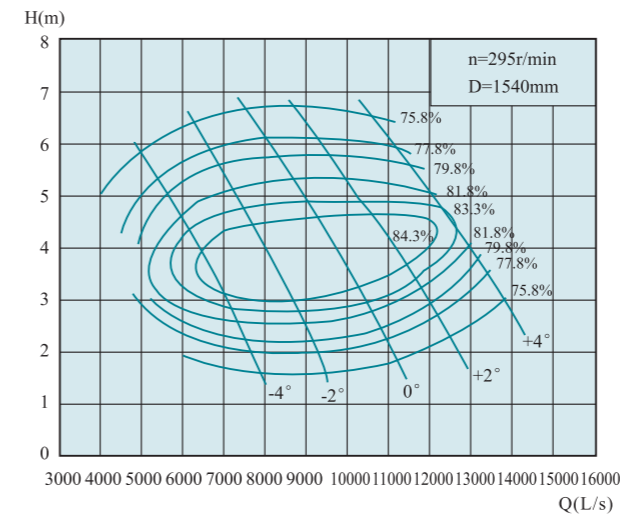

叶片安装角度 Angle	流量Q Capacity		扬程H Head (m)	转速n Speed (r/min)	功率P Power(kw)		效率η Eff. (%)	叶轮直径 Diameter of impeller (mm)
	(m³/h)	(L/s)			轴功率 Shaft power	电机功率 Motor power		
-4°	26947.8	7485.5	2.23	295	205.2	400	79.8	1540
	24570	6825	3.3		262.1		84.3	
	19616.4	5449	5.38		369.6		77.8	
-2°	32991.1	9164.2	2.21		249	560	79.8	
	30415.3	8448.7	3.42		334.7		84.7	
	23975.6	6659.9	5.82		488.7		77.8	
0°	38935.8	10815.5	2.49		331.1	710	79.8	
	35864.3	9962.3	3.77		431.9		85.3	
	28830.2	8008.4	6.11		617		77.8	
+2°	43295	12026.4	2.94		434.7	800	79.8	
	39827.2	11063.1	3.9		499.7		84.7	
	33387.5	9274.3	6.11		714.5		77.8	
+4°	47257.9	13127.2	3.77	608.4	900	79.8		
	45276.5	12576.8	4.32	637.6		83.6		
	40421.9	11228.3	5.9	835.3		77.8		

1600QZ-160C

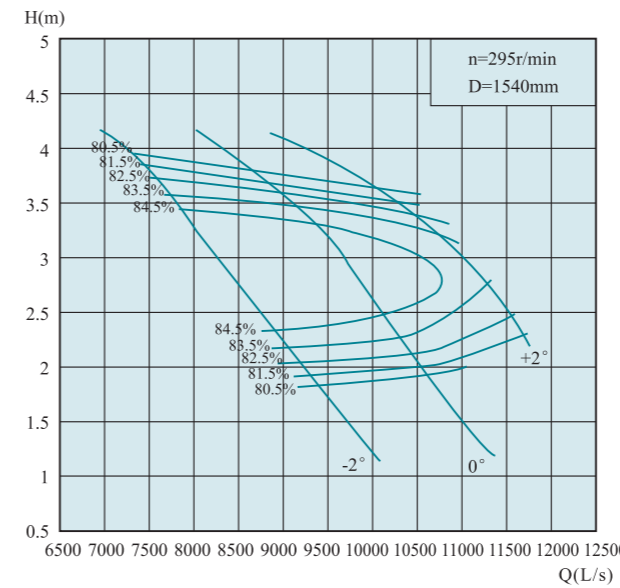

叶片安装角度 Angle	流量Q Capacity		扬程H Head (m)	转速n Speed (r/min)	功率P Power(kw)		效率η Eff. (%)	叶轮直径 Diameter of impeller (mm)
	(m³/h)	(L/s)			轴功率 Shaft power	电机功率 Motor power		
-2°	33550.2	9319.5	1.92	295	215.1	400	81.6	1540
	30712.7	8531.3	2.72		264.4		84.1	
	26896	7471.2	3.85		345.8		81.6	
0°	37918.1	10532.8	1.99		252	450	81.6	
	35666.3	9907.3	2.73		311.8		85.1	
	31770.7	8825.2	3.69		391.5		81.6	
+2°	42017.8	11671.6	2.29		321.3	500	81.6	
	39827.2	11063.1	2.94		381.7		83.6	
	36897.8	10249.4	3.52		433.7		81.6	

外形安装尺寸图 Outline installation dimension drawing

1600QZ-70, 1600QZ-85, 1600QZ-100, 1600QZ-125, 1600QZ-160
1600QZ-70C, 1600QZ-85C, 1600QZ-100C, 1600QZ-125C, 1600QZ-160C

1、井筒悬吊式安装
Suspension installation of wellbore

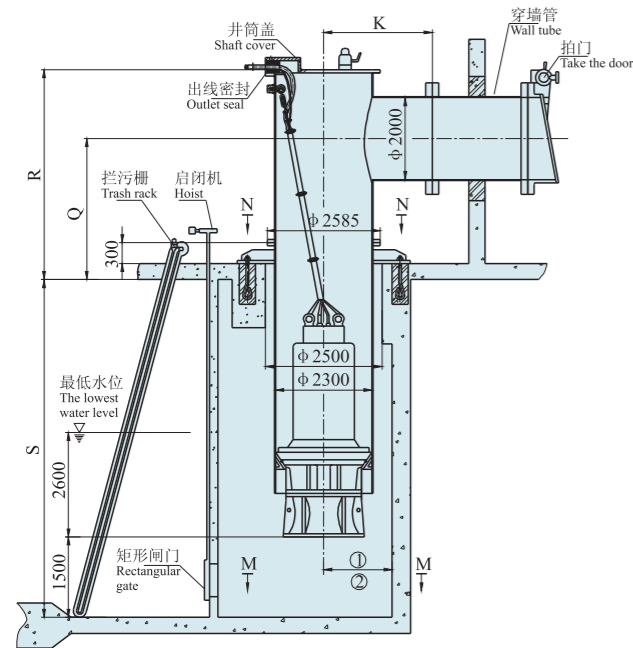

2、混凝土预制井筒式安装
Precast concrete shaft installation

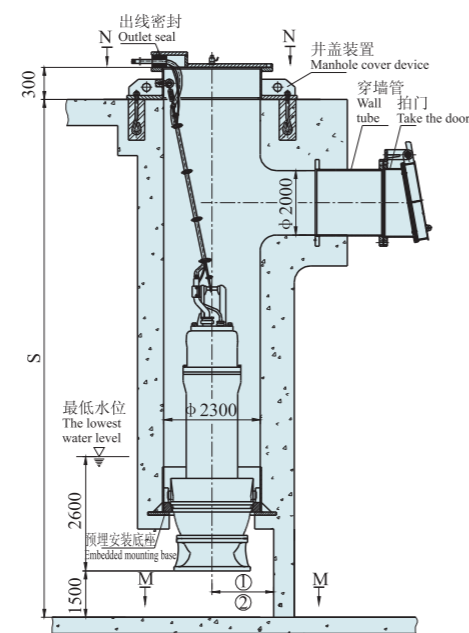

3、弯管悬吊式安装
Bend suspension installation

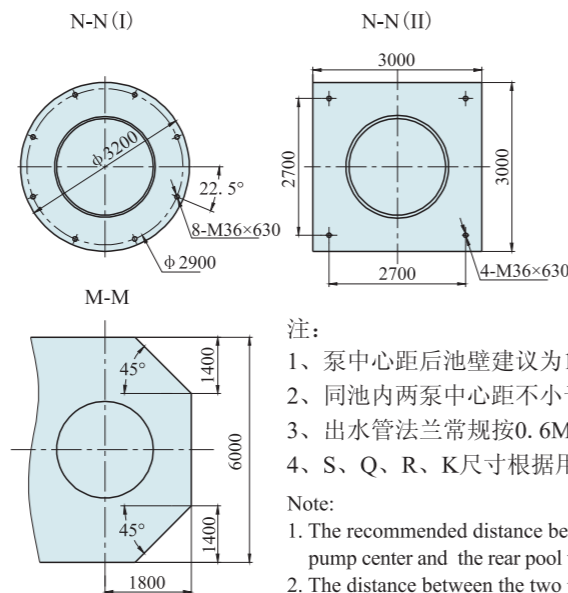
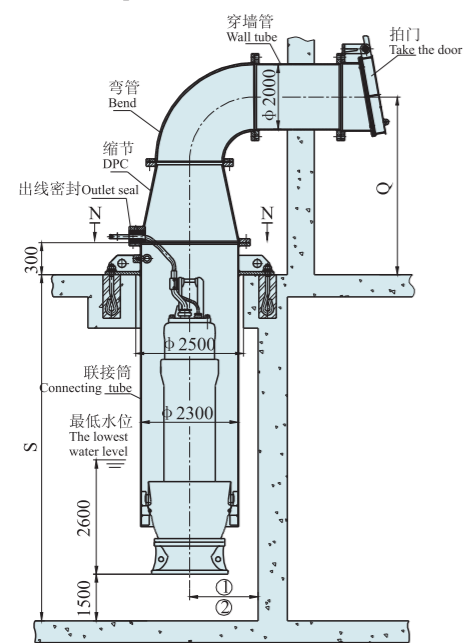

- 注:
- 1、泵中心距后池壁建议为1800;
 - 2、同池内两泵中心距不小于6000;
 - 3、出水管法兰常规按0.6MPa;
 - 4、S、Q、R、K尺寸根据用户要求。

- Note:
1. The recommended distance between the pump center and the rear pool wall is 1800;
 2. The distance between the two pump centers in the same pool shall not be less than 6000;
 3. The outlet pipe flange is normally 0.6mpa;
 4. Sizes of S, Q, R and K are according to user requirements.

QZ、QH型潜水轴流泵、混流泵性能曲线图与性能参数表 Curve and specification

1800QZX-70

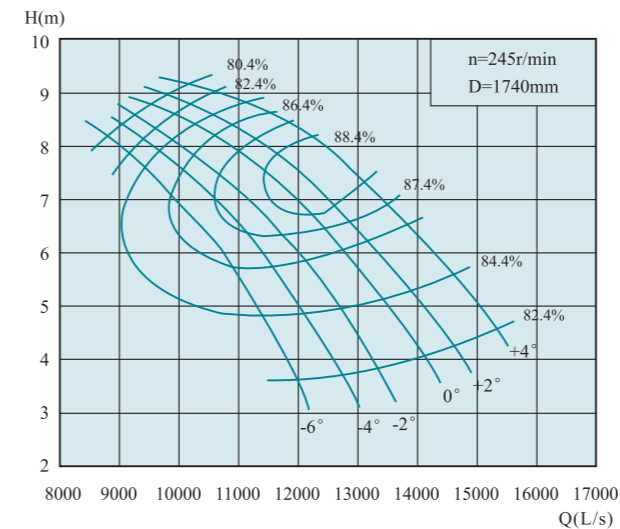

叶片安装角度 Angle	流量Q Capacity		扬程H Head (m)	转速n Speed (r/min)	功率P Power(kw)		效率η Eff. (%)	叶轮直径 Diameter of impeller (mm)		
	(m³/h)	(L/s)			轴功率 Shaft power	电机功率 Motor power				
-6°	42725.5	11868.2	3.6	245	508.7	1000	82.4	1740		
	37978.2	10549.5	6.34		759.4					
	31450.7	8736.3	8.16		869.8					
-4°	45692.6	12692.4	3.7		559.1	1100	82.4			
	38927.5	10813.2	6.72		813.7		87.6			
	32637.6	9066	8.53		943.6		80.4			
-2°	48066.1	13351.7	3.84		610.4	1100	82.4		1740	
	40945.3	11373.7	7.01		890.8		87.8			
	33349.7	9263.8	8.64		976.6		80.4			
0°	50440	14011.1	4.13		688.9	1200	82.4			1740
	42606.7	11835.2	7.32		956		88.9			
	34180.6	9494.6	8.93		1034.5		80.4			
+2°	52220.2	14505.6	4.32	746	1200	82.4	1740			
	43674.8	12131.9	7.4	986.2		89.3				
	34536.6	9593.5	9.03	1057		80.4				
+4°	54830.9	15230.8	4.71	854.1	1200	82.4		1740		
	45336.6	12593.5	7.88	1101.3		88.4				
	36672.8	10186.9	9.22	1146		80.4				

1800QZX-85

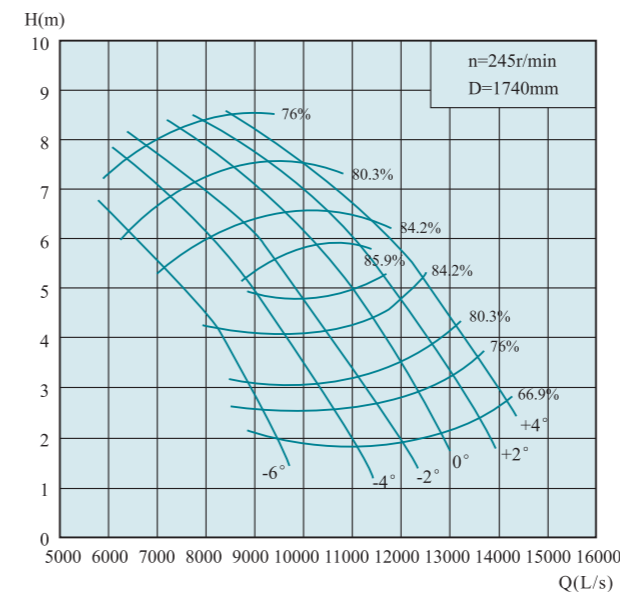

叶片安装角度 Angle	流量Q Capacity		扬程H Head (m)	转速n Speed (r/min)	功率P Power(kw)		效率η Eff. (%)	叶轮直径 Diameter of impeller (mm)			
	(m³/h)	(L/s)			轴功率 Shaft power	电机功率 Motor power					
-6°	32162.8	8934.1	2.68	245	308.7	560	76.1	1740			
	29433.2	8175.9	4.07		383.6		85.1				
	20769.5	5769.3	6.87		510.9		76.1				
-4°	37266.1	10351.7	2.59		345.6	630	76.1		1740		
	31806.7	8835.2	4.99		502.3		86.1				
	22786.9	6329.7	7.29		594.8		76.1				
-2°	41894.6	11637.4	2.68		402	710	76.1			1740	
	36198	10055	4.9		561.4		86.1				
	25042	6956.1	7.64		685.1		76.1				
0°	45099	12527.5	2.93		473.2	900	76.1				1740
	39639.6	11011	5.08		630		87.1				
	27534.2	7648.4	7.92		780.9		76.1				
+2°	48184.9	13384.7	3.36	579.7	1000	76.1	1740				
	42369.5	11769.3	5.43	728.1		86.1					
	30026.5	8340.7	8.15	876.3		76.1					
+4°	51270.5	14241.8	3.77	692.1	1100	76.1		1740			
	43318.8	12033	6.14	851.7		85.1					
	32756	9098.9	8.14	954.8		76.1					

QZ、QH型潜水轴流泵、混流泵性能曲线图与性能参数表 Curve and specification

1800QZX-100

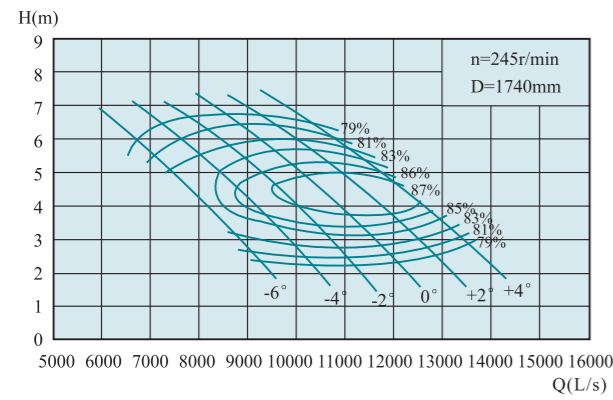

叶片安装角度 Angle	流量Q Capacity		扬程H Head (m)	转速n Speed (r/min)	功率P Power(kw)		效率η Eff. (%)	叶轮直径 Diameter of impeller (mm)
	(m³/h)	(L/s)			轴功率 Shaft power	电机功率 Motor power		
-6°	31569.5	8769.3	3.07	245	317.8	500	83.1	1740
	29670.5	8241.8	3.87		369.4		84.7	
	26703.4	7417.6	5.09		445.7		83.1	
-4°	36079.2	10022	2.81		332.5	560	83.1	
	33230.9	9230.8	3.94		413.9		86.2	
	29017.8	8060.5	5.52		525.3		83.1	
-2°	39283.6	10912.1	2.74		353	630	83.1	
	36198	10055	4.04		459.1		86.8	
	31094.6	8637.4	5.79		590.4		83.1	
0°	42369.5	11769.3	2.82		391.8	710	83.1	
	39165.1	10879.2	4.03		493.8		87.1	
	33409.1	9280.3	6		657.3		83.1	
+2°	45099	12527.5	3.04	449.6	800	83.1		
	41538.6	11538.5	4.25	549.2		87.6		
	36079.2	10022	6.02	712.2		83.1		
+4°	47472.8	13186.9	3.34	519.9	751	83.1		
	44505.7	12362.7	4.27	593.2		87.3		
	39758.4	11044	5.76	751		83.1		

1800QZX-125

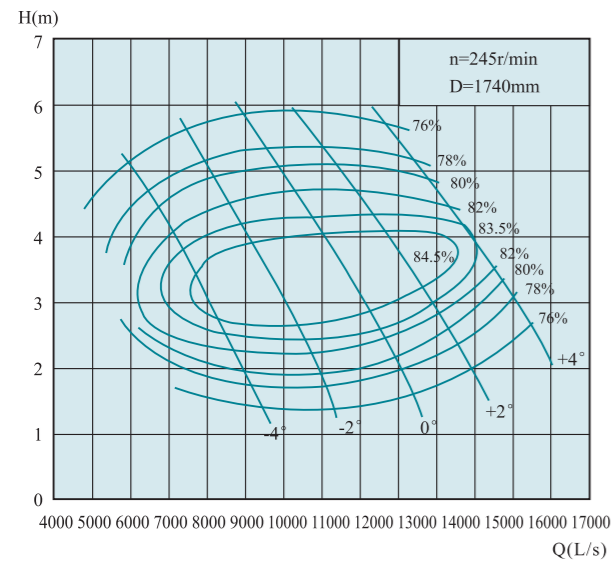

叶片安装角度 Angle	流量Q Capacity		扬程H Head (m)	转速n Speed (r/min)	功率P Power(kw)		效率η Eff. (%)	叶轮直径 Diameter of impeller (mm)
	(m³/h)	(L/s)			轴功率 Shaft power	电机功率 Motor power		
-4°	32281.6	8967.1	1.96	245	215.5	450	80	1740
	29433.2	8175.9	2.91		276.2		84.5	
	23499	6527.5	4.73		388.3		78	
-2°	39521.2	10978.1	1.95		262.5	560	80	
	36435.2	10120.9	3.02		353.2		84.9	
	28721.2	7978.1	5.13		514.7		78	
0°	46642	12956.1	2.19		347.9	710	80	
	42962.8	11934.1	3.32		454.6		85.5	
	34536.6	9593.5	5.38		649.1		78	
+2°	51864.1	14406.7	2.59		457.6	800	80	
	47710.1	13252.8	3.44		526.8		84.9	
	39995.6	11109.9	5.38		751.7		78	
+4°	56611.4	15725.4	3.32	640.2	900	80		
	54237.6	15066	3.8	670.2		83.8		
	48422.2	13450.6	5.5	879.7		78		

QZ、QH型潜水轴流泵、混流泵性能曲线图与性能参数表 Curve and specification

2000QZX-70

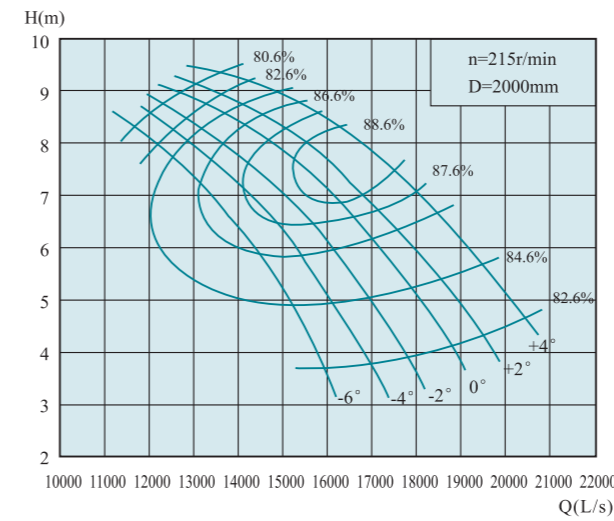

叶片安装角度 Angle	流量Q Capacity		扬程H Head (m)	转速n Speed (r/min)	功率P Power(kw)		效率η Eff. (%)	叶轮直径 Diameter of impeller (mm)
	(m³/h)	(L/s)			轴功率 Shaft power	电机功率 Motor power		
-6°	56938	15816.1	3.66	215	686.7	1100	82.7	2000
	50611.3	14058.7	6.45		1026		86.7	
	46080	12800	7.6		1086		82.6	
-4°	60891.8	16914.4	3.76		754.4	1200	82.7	
	51876.7	14410.2	6.84		1100		87.9	
	46440.3	12900.1	8.0		1144		86.6	
-2°	64055.2	17793.1	3.91		825.3	1300	82.7	
	54565.6	15157.1	7.13		1203.4		88.1	
	44082.2	12245.3	8.2		1113.5		86.6	
0°	67218.5	18671.8	4.2		930.2	1400	82.7	
	56779.9	15772.2	7.45		1292.3		89.2	
	50760.1	14100	8.0		1251.4		80.7	
+2°	69590.9	19330.8	4.4	1008.9	1500	82.7		
	58203.4	16167.6	7.52	1331.1		89.6		
	54000	15000	8.2	1358		87		
+4°	73070.3	20297.3	4.79	1153.3	1443.6	82.7		
	60417.4	16782.6	8.01	1486.7		88.7		
	48871.8	15200	8.6	1443.6		80.7		

2000QZX-85

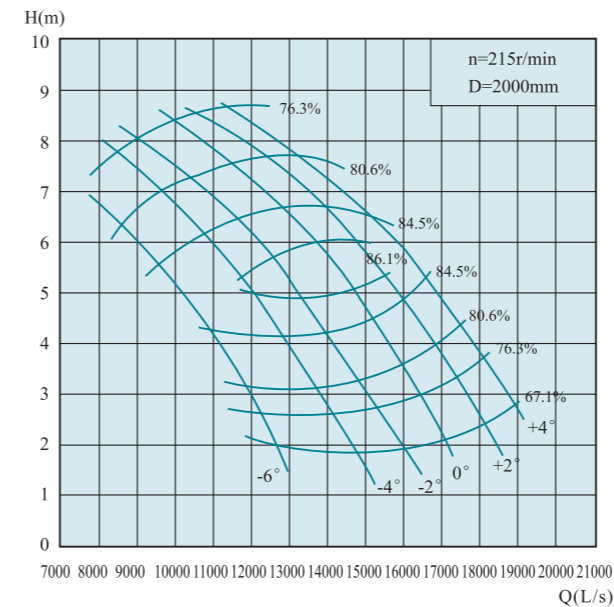

叶片安装角度 Angle	流量Q Capacity		扬程H Head (m)	转速n Speed (r/min)	功率P Power(kw)		效率η Eff. (%)	叶轮直径 Diameter of impeller (mm)
	(m³/h)	(L/s)			轴功率 Shaft power	电机功率 Motor power		
-6°	42861.6	11906	2.73	215	417.4	800	76.4	2000
	39223.8	10895.5	4.14		518.2		85.4	
	27678.2	7688.4	6.99		690.1		76.4	
-4°	49662.4	13795.1	2.64		467.6	900	76.4	
	42387.1	11774.2	5.08		679.1		86.4	
	30366.7	8435.2	7.42		803.7		76.4	
-2°	55831	15508.6	2.73		543.6	1000	76.4	
	48238.9	13399.7	4.98		757.7		86.4	
	33372	9270	7.77		924.9		76.4	
0°	60101.3	16694.8	2.98		638.8	1200	76.4	
	52825.7	14673.8	5.17		851.5		87.4	
	36693.4	10192.6	8.06		1054.9		76.4	
+2°	64213.2	17837	3.42	783.3	1250	76.4		
	56463.5	15684.3	5.52	983		86.4		
	40014.7	11115.2	8.3	1184.6		76.4		
+4°	68325.5	18979.3	3.84	935.8	1300	76.4		
	57728.9	16035.8	6.24	1149.4		85.4		
	43652.5	12125.7	8.29	1290.7		76.4		

QZ、QH型潜水轴流泵、混流泵性能曲线图与性能参数表 Curve and specification

2000QZX-100

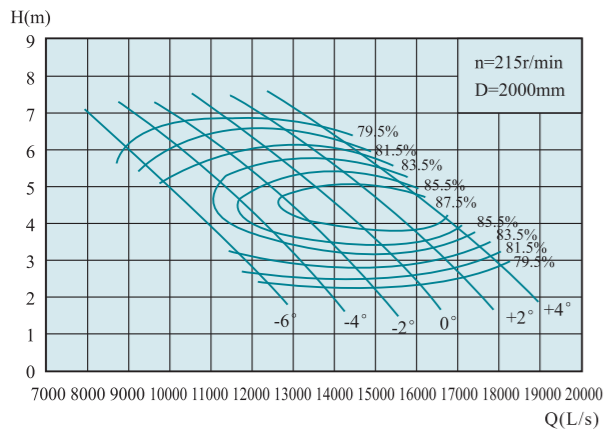

叶片安装角度 Angle	流量Q Capacity		扬程H Head (m)	转速n Speed (r/min)	功率P Power(kw)		效率η Eff. (%)	叶轮直径 Diameter of impeller (mm)
	(m³/h)	(L/s)			轴功率 Shaft power	电机功率 Motor power		
-6°	42070.7	11686.3	3.13	215	429.7	710	83.5	2000
	39540.2	10983.4	3.94		498.9		85.1	
	35586.4	9885.1	5.18		601.6		83.5	
-4°	48080.9	13355.8	2.86		448.8	800	83.5	
	44285	12301.4	4.01		558.8		86.6	
	38670.5	10741.8	5.62		709.2		83.5	
-2°	52351.2	14542	2.78		475	900	83.5	
	48238.9	13399.7	4.11		619.6		87.2	
	41438.2	11510.6	5.89		796.5		83.5	
0°	56463.5	15684.3	2.89		528.8	1000	83.5	
	52193.2	14498.1	4.1		666.4		87.5	
	44522.3	12367.3	6.11		887.8		83.5	
+2°	60101.3	16694.8	3.1	608	1100	83.5		
	55356.5	15376.8	4.33	742.2		88		
	48080.9	13355.8	6.13	961.9		83.5		
+4°	63264.2	17573.4	3.4	702	1100	83.5		
	59310.4	16475.1	4.35	801.7		87.7		
	52984.1	14717.8	5.86	1013.3		83.5		

2000QZX-125

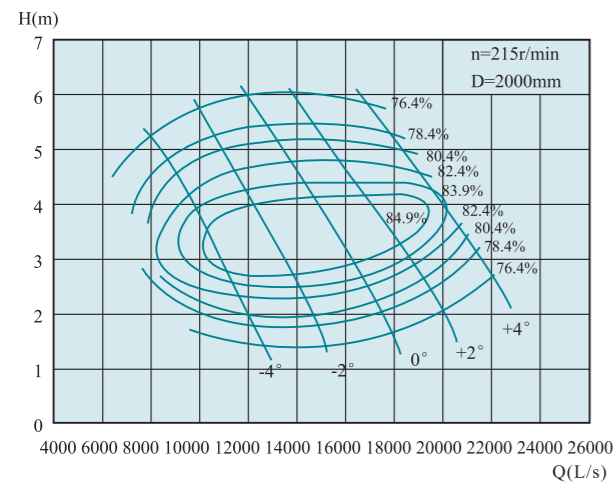

叶片安装角度 Angle	流量Q Capacity		扬程H Head (m)	转速n Speed (r/min)	功率P Power(kw)		效率η Eff. (%)	叶轮直径 Diameter of impeller (mm)
	(m³/h)	(L/s)			轴功率 Shaft power	电机功率 Motor power		
-4°	43019.6	11949.9	1.99	215	290.2	560	80.4	2000
	39223.8	10895.5	2.96		372.6		84.9	
	31316	8698.9	4.82		524.6		78.4	
-2°	52667.6	14629.9	1.98		353.4	800	80.4	
	48555.4	13487.6	3.07		476.2		85.3	
	38274.8	10631.9	5.22		694.4		78.4	
0°	62157.2	17265.9	2.23		469.8	1000	80.4	
	57254.4	15094	3.38		613.9		85.9	
	46024.9	12784.7	5.47		875		78.4	
+2°	69116.4	19199	2.64		618.4	1100	80.4	
	63580.7	17661.3	3.5		710.9		85.3	
	53300.2	14805.6	5.47		1013.4		78.4	
+4°	75442.7	20956.3	3.38	864.3	1200	80.4		
	72279.7	20077.7	3.87	905.3		84.2		
	64529.6	17924.9	5.29	1186.5		78.4		

QZ、QH型潜水轴流泵、混流泵性能曲线图与性能参数表 Curve and specification

2400QZX-85

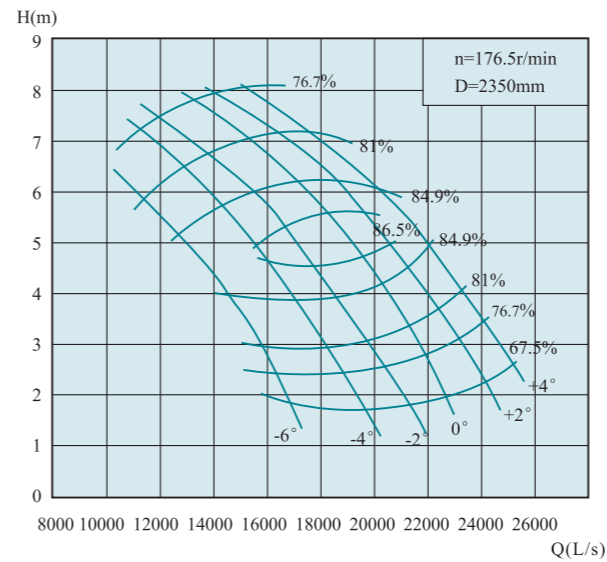

叶片安装角度 Angle	流量Q Capacity		扬程H Head (m)	转速n Speed (r/min)	功率P Power(kw)		效率η Eff. (%)	叶轮直径 Diameter of impeller (mm)
	(m³/h)	(L/s)			轴功率 Shaft power	电机功率 Motor power		
-6°	57080.5	15855.7	2.54	176.5	514.4	900	76.8	2350
	52236	14510	3.85		638.7		85.8	
	36860	10238.9	6.5		850.1		76.8	
-4°	66137.8	18371.6	2.45		574.9	1100	76.8	
	56448.7	15680.2	4.73		838.2		86.8	
	40441	11233.6	6.9		990.1		76.8	
-2°	74352.2	20653.4	2.54		670.1	1200	76.8	
	64242	17845	4.64		935.8		86.8	
	44442.7	12345.2	7.23		1140.1		76.8	
0°	80039.2	22233.1	2.77		786.7	1350	76.8	
	70350.1	19541.7	4.81		1050.2		87.8	
	48866	13573.9	7.5		1300.4		76.8	
+2°	85515.5	23754.3	3.18	964.9	1400	76.8		
	75194.6	20887.4	5.14	1213.4		86.8		
	53200.4	16200	7.0	1345.6		81.1		
+4°	90991.8	25275.5	3.57	1152.6	1500	76.8		
	76879.8	21355.5	5.81	1418.6		85.8		
	58133.9	17500.3	7.1	1453.3		81.1		

2400QZX-100

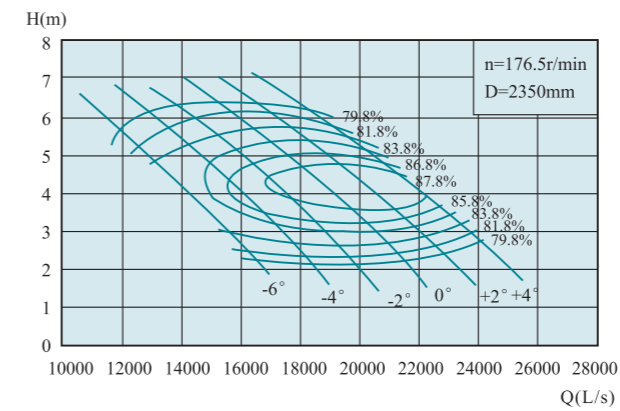

叶片安装角度 Angle	流量Q Capacity		扬程H Head (m)	转速n Speed (r/min)	功率P Power(kw)		效率η Eff. (%)	叶轮直径 Diameter of impeller (mm)
	(m³/h)	(L/s)			轴功率 Shaft power	电机功率 Motor power		
-6°	56027.5	15563.2	2.91	176.5	530.2	800	83.8	2350
	52657.2	14627	3.66		615		85.4	
	47391.5	13164.3	4.82		742.8		83.8	
-4°	64031.4	17786.5	2.66		553.9	900	83.8	
	58976.3	16382.3	3.73		689.8		86.9	
	51498.7	14305.2	5.23		875.8		83.8	
-2°	69718.3	19366.2	2.59		587.2	1100	83.8	
	64242	17845	3.83		766.3		87.5	
	55184.8	15329.1	5.48		983.4		83.8	
0°	75194.6	20887.4	2.67		652.9	1150	83.8	
	69507.7	19307.7	3.82		824.1		87.8	
	59292.4	16470.1	5.68		1095.1		83.8	
+2°	80039.2	22233.1	2.88	749.6	1200	83.8		
	73720.4	20477.9	4.03	916.9		88.3		
	64031.4	17786.5	5.7	1186.8		83.8		
+4°	84251.9	23403.3	3.16	865.7	1300	83.8		
	78986.2	21940.6	4.05	990.6		88		
	70560.7	19600.2	5.46	1252.8		83.8		

QZ、QH型潜水轴流泵、混流泵性能曲线图与性能参数表 Curve and specification

2400QZX-125

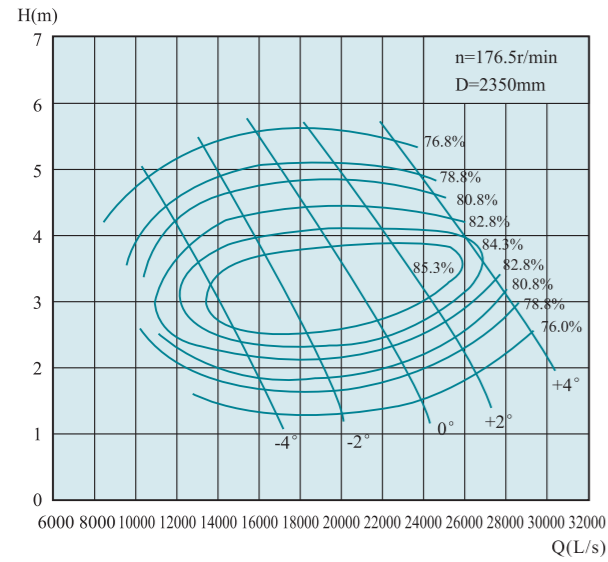

叶片安装角度 Angle	流量Q Capacity		扬程H Head (m)	转速n Speed (r/min)	功率P Power(kw)		效率η Eff. (%)	叶轮直径 Diameter of impeller (mm)
	(m³/h)	(L/s)			轴功率 Shaft power	电机功率 Motor power		
-4°	57291.1	15914.2	1.85	176.5	357.4	710	80.8	2350
	52236	14510	2.75		458.9		85.3	
	41704.6	11584.6	4.48		646.1		78.8	
-2°	70139.5	19483.2	1.85		437.6	900	80.8	
	64663.2	17962	2.85		586		85.7	
0°	82777.3	22993.7	2.07		577.9	1150	80.8	
	76248	21180	3.15		758.4		86.3	
+2°	92045.2	25568.1	2.45		760.5	1300	80.8	
	8673.1	23520.3	3.25		875		85.7	
+4°	70982.3	19717.3	5.09		1249.4		78.8	
	100470.2	27908.4	3.15		1067.3	1500	80.8	
	96257.5	26738.2	3.6		1116.2		84.6	
	85936.7	23871.3	4.92	1462.1		78.8		

2400QZX-160

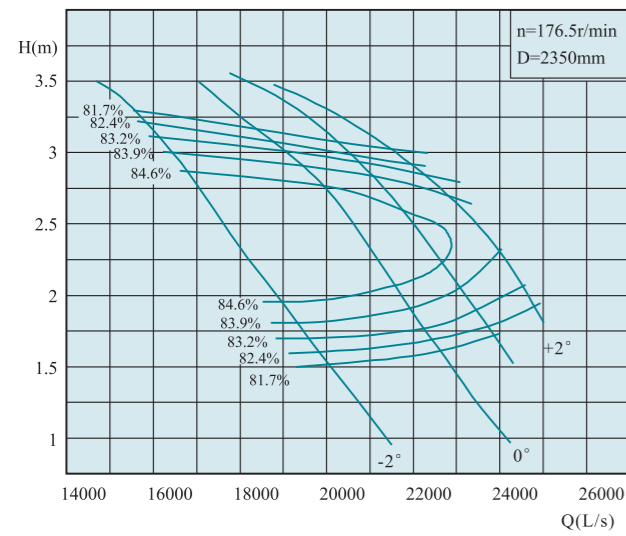

叶片安装角度 Angle	流量Q Capacity		扬程H Head (m)	转速n Speed (r/min)	功率 Power(kw)		效率η Eff. (%)	叶轮外径 D Outer dia- meter of impeller (mm)
	(m³/h)	(L/s)			轴功率 Shaft power	电机功率 Motor power		
-2°	57181.5	15884	3.21	176.5	602	710	83.2	2350
	65295.5	18138	2.27		468		86.2	
	71327.9	19813	1.60		374		83.2	
0°	67544.3	18762	3.07		679	800	83.2	
	75826.4	21063	2.27		549		85.6	
	80614.6	22393	1.65		436		83.2	
+2°	78445.1	21790	2.93		754	900	83.2	
	84673.3	23520	2.45		670		84.6	
	89330.4	24814	1.91		560		83.2	

大型潜水轴混流泵簸箕型和肘型流道混凝土预制井筒式安装尺寸
Large submersible axial/mixed-flow pump dustpan type and elbow type runner concrete precast wellbore mounting dimensions

1200-2400口径大型潜水轴混流泵簸箕型流道混凝土预制井筒式安装尺寸图表
Size chart of precast wellbore installation of concrete dustpan type flow passage of large submersible shaft mixed flow pump with diameter 1200-2400

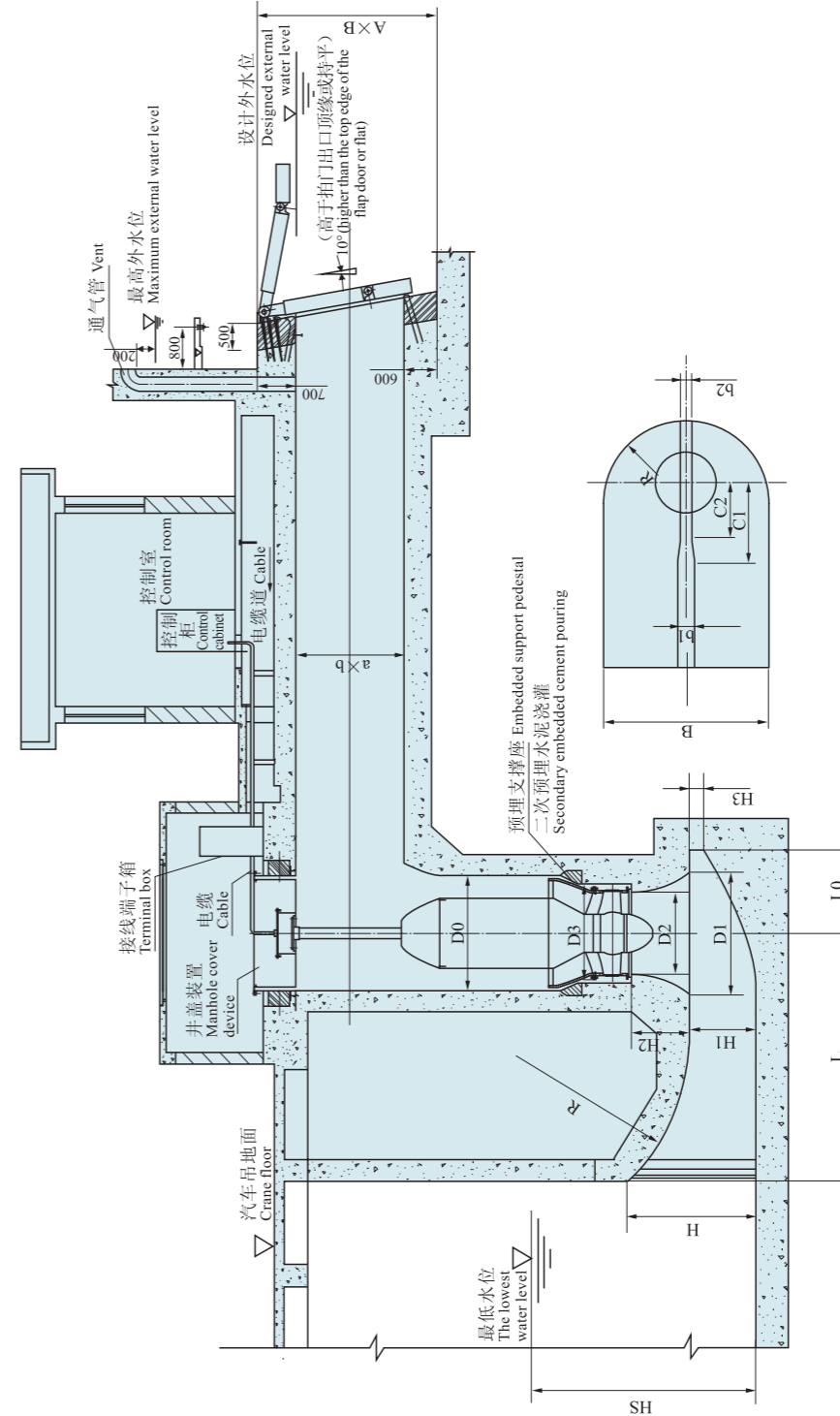

序号 No.	型号 Type	n(r/min)	HS	φD0	φD1	φD2	φD3	H	H1	H2	H3	B	L	L0	C1	C2	R	R1	b1	b2	a×b
1	1200QZ	490	3700	1700	1423	955	1250	1527	780	679	165	2590	2910	970	1260	866	2748	1293	300	100	1400×1000
2	1400QZ	370	4200	1800	1760	1180	1600	1889	960	840	204	3200	3600	1200	1562	1071	3400	1600	300	100	1600×2200
3	1600QZ	295	4700	2100	2120	1427	1700	2280	1160	1015	246	3867	4350	1450	1887	1294	4108	1933	400	200	1800×2400
4	1600QZC	295	5000	2300	2259	1540	1900	2424	1230	1078	260	4100	4620	1540	2000	1375	4363	2053	400	200	1800×2400
5	1800QZX	245	5200	2400	2552	1712	2000	2738	1392	1277	296	4640	5220	1740	2371	1553	4929	2320	400	200	1800×2400
6	2000QZX	215	5800	2800	2933	1968	2400	3418	1600	1467	340	5333	6000	2725	1785	5666	2667	400	200	2400×3000	
7	2400QZX	176.5	6500	3200	3447	2350	2750	3699	1880	1644	400	6276	7050	3350	3058	2097	6658	3133	400	200	2800×3400
8	1200QH	490	3370	1750	1320	886	1500	720	720	630	155	2400	2700	900	1171	800	2550	1200	300	100	1400×1000
9	1300QH	490	3540	1800	1423	969	1600	1527	776	678	165	2587	2910	970	1262	866	2748	1293	300	100	1400×1000
10	1400QH	370	3760	2000	1687	1150	1700	1810	920	805	195	3070	3450	1150	1497	1026	3258	1533	300	100	1600×2200

大型潜水轴混流泵簸箕型和肘型流道混凝土预制井筒式安装尺寸
Large submersible axial/mixed-flow pump dustpan type and elbow type runner concrete precast wellbore mounting dimensions

1200-2400口径大型潜水电泵肘型进水渠道水泥井筒式安装尺寸图表
Size chart of cement wellbore installation for elbow inlet passage of large submersible electric pump with diameter from 1200-2400

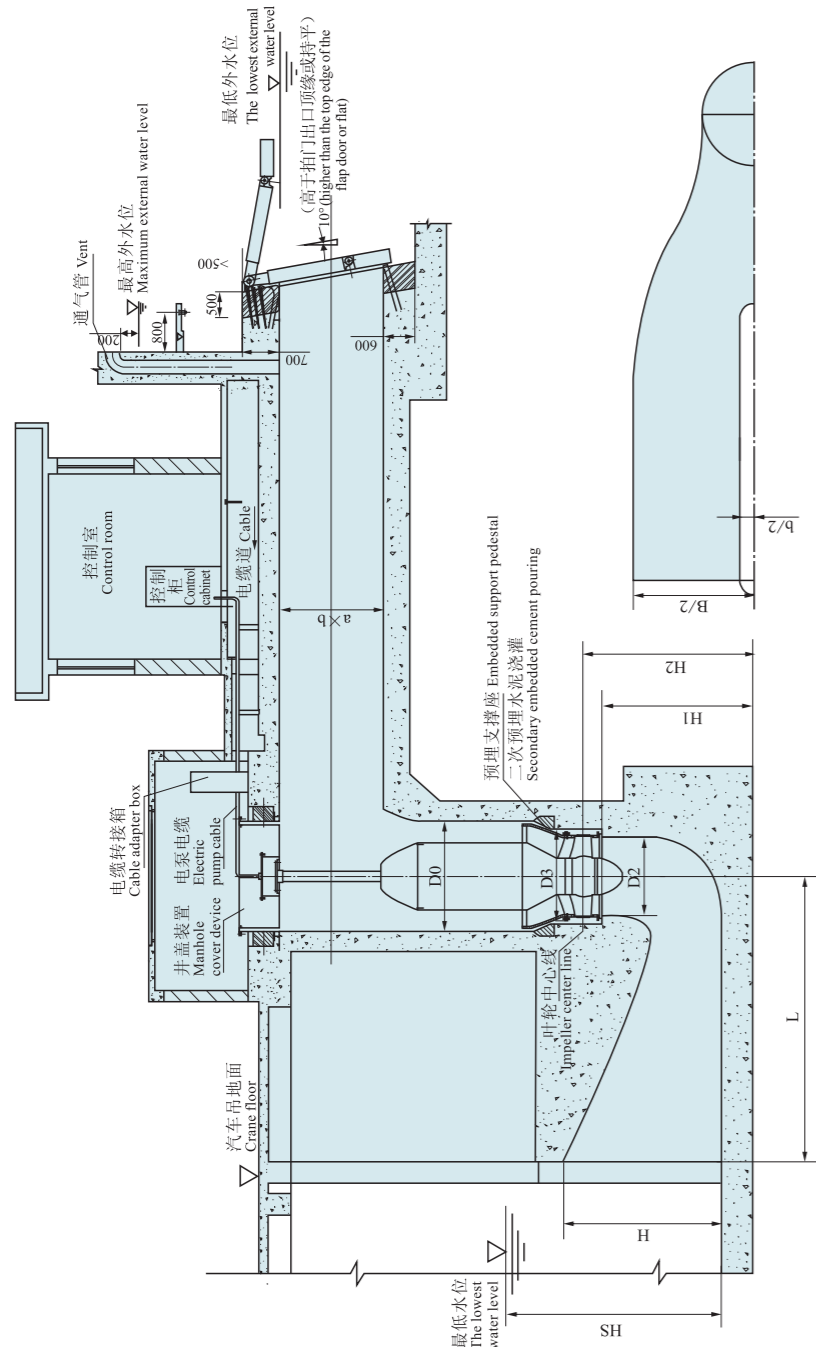

序号 No.	型号 Type	n(r/min)	HS	φD0	φD2	φD3	H	H1	H2	B	L	b1	a × b
1	1200QZ	490	3700	1700	955	1250	1940	1533	1700	2260	3500	300	1400 × 1000
2	1400QZ	370	4200	1800	1180	1600	2400	1896	2103	2795	4330	300	1600 × 2200
3	1600QZ	295	4700	2100	1427	1700	2900	2292	2541	3378	5232	400	1800 × 2400
4	1600QZC	295	5000	2300	1540	1900	3080	2434	2699	3588	5557	400	1800 × 2400
5	1800QZX	245	5500	2400	1712	2000	3480	2750	3049	4054	6278	400	1800 × 2400
6	2000QZX	215	5800	2800	1968	2400	4000	3161	3505	4659	7216	400	2400 × 3000
7	2400QZX	176.5	6500	3200	2350	2750	4700	3714	4119	5475	8479	400	2800 × 3400
8	1200QH	490	3370	1750	886	1500	1800	1422	1577	2096	3247	300	1400 × 1000
9	1300QH	490	3540	1800	969	1600	1940	1533	1700	2260	3500	300	1400 × 1000
10	1400QH	370	3760	2000	1150	1700	2300	1817	2015	2679	4149	300	1600 × 2200

该流道的具体型号与各个截面的断面图请与我司技术科联系。
For the specific model of the channel, please contact the technical department of our company for the sectional drawing of each section of the elbow channel.

开敞式流道水力设计参考 Hydraulic design reference of open runner

开敞式进水(进水池)结构简单, 施工方便, 在中小型泵站的应用非常广泛。国内外对这种流道的水力设计都很重视, 做了大量的试验研究工作。许多研究者都是根据试验结果, 以经验系数的形式提出了开敞式进水池的设计准则。可是, 各家提出的准则出入很大, 至今还没有统一的或是最优的水力设计准则。

Open inlet (inlet tank) has simple structure and convenient construction, and is widely used in small and medium-sized pump stations. Both at home and abroad, great attention has been paid to the hydraulic design of this flow channel, and a lot of experimental research has been done. Based on the experimental results, many researchers put forward the design criterion of open inlet tank in the form of empirical coefficient. However, the standards proposed vary greatly, so far there is no unified or optimal hydraulic design criteria.

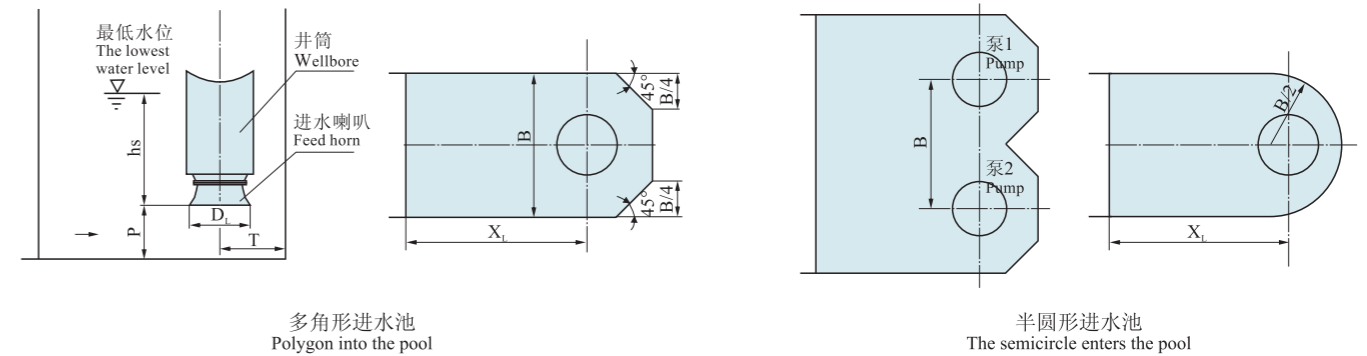

进水池几何尺寸 Geometry of inlet tank	日本机械学会 Japan machinery institute	英国流体力学工程学会 British society for fluid mechanical engineering	美国水力研究所 American hydraulic research institute	溧阳双桥站现场测试 Liyang shuangqiao station site test	建议取值 Recommended values	使用条件 Conditions of use
池宽B/D _L Width of pool	2.0~2.5	2~3	2.6~2.8	2.0~2.5	2.0~2.5	小泵取小值, 大泵取大值 The small pump takes the small value, the big pump takes the big value
泵间距B/D _L Pump spacing	2.0~2.5	2~3	2.6~2.8	2.0~2.5	2.0~2.5	小泵取小值, 大泵取大值 The small pump takes the small value, the big pump takes the big value
悬空高P/D _L Hung up high	0.5~0.75	0.5~0.75	0.52~0.59	0.5~0.7	0.5~0.7	小泵取小值, 大泵取大值 The small pump takes the small value, the big pump takes the big value
后壁距T/D _L The back of	0.8~1.0	0.75	1.2~1.4		0.5~0.75	
池长X ₁ /D _L length of pool		4.0		8.0	5~8	

开敞式进水(进水池)的水力设计, 一般以喇叭管进口直径DL为基本参数, 其原因主要是: 进泵水流首先通过喇叭管管口与流道底板之间的圆柱面, 然后再经喇叭管口进入水泵。进水流道尺寸的确定以喇叭管进口直径为基本参数也就是很自然的事。但问题在于, 目前设计的喇叭管并未实现标准化, 喇叭管进口直径是一个变数, 喇叭管进口直径与水泵叶轮直径的比值都一定相同, 若再以DL为基本参数, 就会给水力设计准则造成混淆, 显得不太适宜。

In the hydraulic design of open inlet water (inlet pool), the diameter DL of horn pipe inlet is generally taken as the basic parameter. The main reasons are as follows: first, the inlet water passes through the cylinder between the nozzle of horn pipe and the bottom plate of the passage, and then enters the pump through the nozzle. It is natural that the inlet diameter of horn pipe is the basic parameter for the determination of inlet diameter. However, the problem is that the current design of horn tube has not been standardized. The inlet diameter of horn tube is a variable, and the ratio between the inlet diameter of horn tube and the diameter of pump impeller must be the same. If DL is taken as the basic parameter, it will cause confusion to the hydraulic design criteria, which is not appropriate.

若喇叭管能实现标准化，进水流道的水力设计以喇叭口直径或叶轮直径为基本参数都一样，若不然，则应以水泵叶轮直径为基本参数。

本公司此次编制样本，对各项参数的选择均以叶轮直径D0为基本参数。

依据资料《泵站进水流道优化水力设计》，以开敞式进水推荐设计如下：

(1) 悬空高P

推荐悬空高为 $P=(0.68\sim 1.2)D0$ ，较大的喇叭管进口直径(1.67D0)取小值，较小的喇叭管进口直径(1.46D0)取大值；对于更大一些或更小一些的喇叭管进口直径，悬空高的取值仍可在这个范围内。

(2) 后壁距T

后壁距的确定基本不受所用喇叭管进口直径的影响。喇叭管吸水时一部分水流必须从喇叭管后部进泵，因而一定的后壁距是必要的；然而，过大的后壁距增加了水流在后壁空间的自由度，加大了涡带产生的可能，需相应地增加淹没水深。根据优化计算的结果，后壁距取 $(0.8\sim 1.0)D0$ ，也就足以满足要求。

(3) 池宽B、泵间距B

为使一部分水流顺利从喇叭管两侧及后部进泵，需要有一定的池宽；过大的池宽会徒然地增加土建投资。喇叭管进口直径在一定程度上影响到最佳池宽的确定，根据优化计算的结果，推荐池宽为 $(3.5\sim 4.5)D0$ ，较大的喇叭管进口直径取小值，轻小的喇叭管进口直径取大值。

(4) 池长XL

在正向进水的情况下，为使水流在到喇叭管之前能达到大体均匀的状况，足够的池长是必要的。池长可按泵房上部结构的布置要求确定，一般可取 $(7.0\sim 8.0)D0$ ；在侧向进水的情况下，池长还需适当加大或采取必要的整流措施。池长的确定与所用喇叭管进口直径的大小无关。

(5) 平面形状

计算结果表明，进水池平面形状对泵的工作状态并无多少影响；根据试验资料，平面形状对进水池的水力损失有一定影响，心形的水力损失最小，距形的水力损失最大。

If the horn tube can be standardized, the hydraulic design of inlet passage takes the horn mouth diameter or impeller diameter as the basic parameters, otherwise, the pump impeller diameter should be taken as the basic parameters.

The sample prepared by the company, the selection of the parameters are based on the impeller diameter D0 as the basic parameters.

According to the data "optimal hydraulic design of inlet passage of pump station", the recommended design of open inlet is as follows:

(1) suspension height P

It is recommended that the suspension height is $P=(0.68\sim 1.2)D0$, the larger horn tube inlet diameter (1.67D0) is taken as a small value, and the smaller horn tube inlet diameter (1.46D0) is taken as a large value. For larger or smaller horn tube inlet diameter, the value of suspension height can still be within this range.

(2) back wall distance T

The determination of the back wall distance is basically independent of the diameter of the horn tube inlet. When the horn pipe suction water, part of the flow must be from the back of the horn pipe into the pump, so a certain back wall distance is necessary; However, the excessive backwall distance increases the freedom of water flow in the backwall space, increases the possibility of vortex belt generation, and the submerged depth should be increased accordingly. According to the results of optimization calculation, the distance between the rear wall and the wall is $(0.8\sim 1.0)D0$, which is enough to meet the requirements.

(3) pool width B pump spacing B

In order to make part of the water flow smoothly from both sides of the horn tube and the rear into the pump, it is necessary to have a certain pool width; Too much pool width will increase investment in civil engineering in vain. The diameter of horn tube inlet influences the determination of the optimal pool width to a certain extent. According to the results of optimization calculation, it is recommended that the pool width is $(3.5\sim 4.5)D0$. The larger horn tube inlet diameter is taken as a small value, while the lighter horn tube inlet diameter is taken as a large value.

(4) the pool length XL

In the case of forward inflow, sufficient pool length is necessary to achieve a generally uniform flow before reaching the horn tube. Pool length can be determined according to the layout requirements of the superstructure of the pump room, generally acceptable $(7.0\sim 8.0)D0$; In the case of lateral inflow, the pool length should be appropriately increased or necessary rectification measures should be taken. The determination of the pool length is independent of the diameter of the horn inlet.

(5) plane shape

The calculation results show that the plane shape of the inlet tank has little influence on the working state of the pump. According to the experimental data, the plane shape has a certain impact on the hydraulic loss into the pool, the hydraulic loss of the heart shape is the smallest, and the hydraulic loss of the distance shape is the largest.

实际工程中的其他安装方式的应用

Application of other installation methods in practical engineering

潜水电泵安装结构型式(均已在工程中实施)
Installation structure type of submersible electric pump (all implemented in the project)

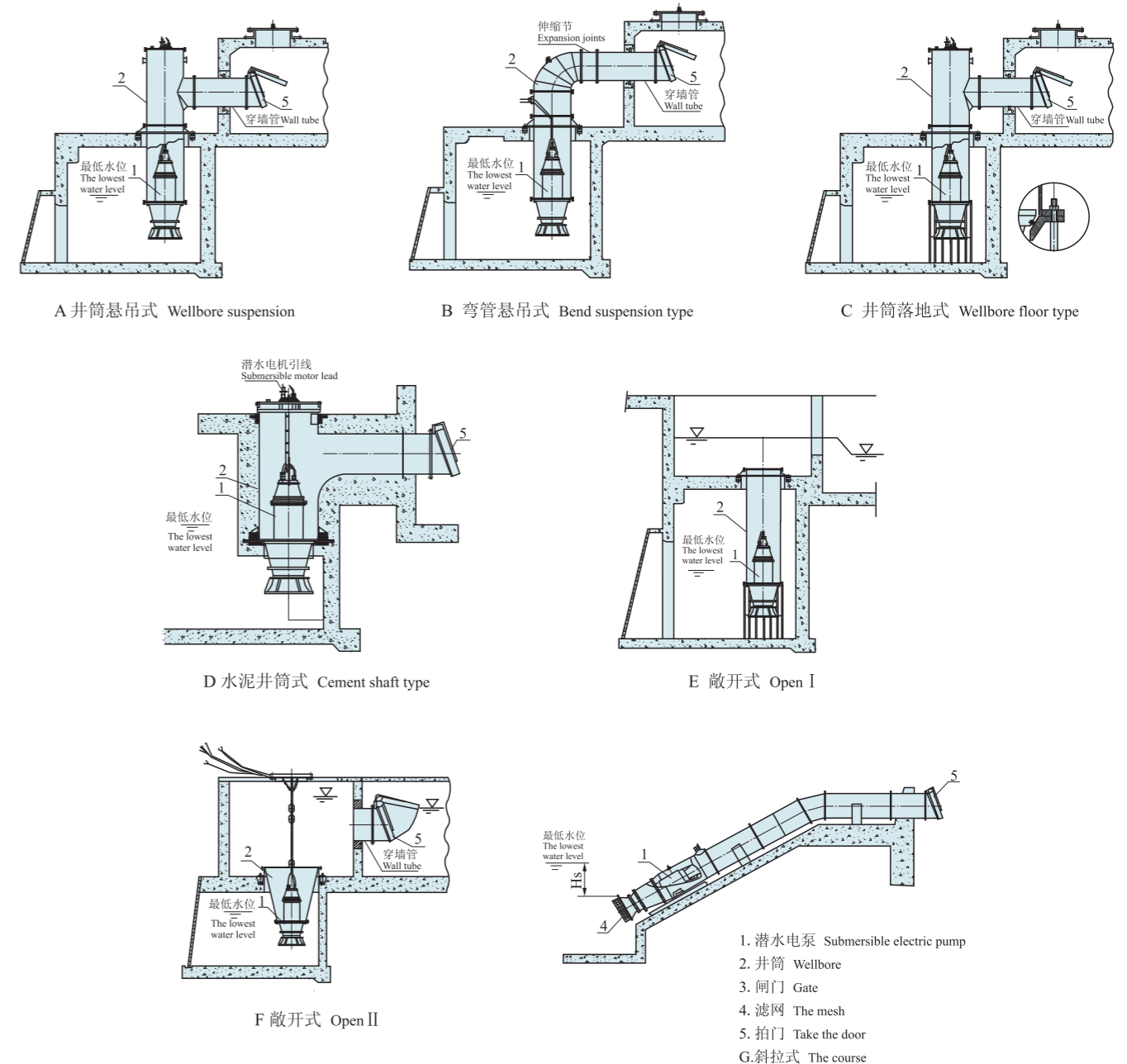

说明：图中前四种安装型式列有安装外形尺寸图和表，推荐A, B, C使用图所示的安装形式，其余安装型式的外形尺寸在咨询时提供。

Description: the first four types of installation in the figure are listed in the outline size diagram and table of installation. It is recommended to use the installation form shown in figure A, B and C, and provide the outline size of the other installation types in consultation.

QZ、QH系列泵重量表 QZ, QH series pump weight

序号 No.	型号 Type	最大泵重 The biggest pump heavy (kg)	最大轴向力 Max. axial force (N)
1	300QZ-50	500	4900
2	300QZ-70	500	4400
3	300QZ-85	500	3500
4	300QZ-100	500	2500
5	350QZ-50	600	10100
6	350QZ-50D	600	4650
7	350QZ-70	600	8950
8	350QZ-70D	550	4100
9	350QZ-85	550	7200
10	350QZ-85D	400	3300
11	350QZ-100	550	5150
12	350QZ-100D	400	2400
13	350QZ-125	550	4800
14	350QZ-125D	400	2200
15	350QZ-160	450	3350
16	500QZ-50	990	23100
17	500QZ-50D	750	12900
18	500QZ-70	990	20450
19	500QZ-70D	700	11400
20	500QZ-85	860	16300
21	500QZ-85D	700	9100
22	500QZ-100	830	11700
23	500QZ-100D	700	6550
24	500QZ-125	830	10950
25	500QZ-125D	700	6100
26	500QZ-160	650	7600
27	500QZ-160D	550	4250
28	600QZ-50	2100	28900
29	600QZ-70	1900	25600
30	600QZ-85	1900	20400
31	600QZ-100	1800	14650
32	600QZ-125	1850	13700

序号 No.	型号 Type	最大泵重 The biggest pump heavy (kg)	最大轴向力 Max. axial force (N)
33	600QZ-160	1700	9500
34	700QZ-50	2500	41000
35	700QZ-50D	2000	26500
36	700QZ-70	2200	36200
37	700QZ-70D	1900	23300
38	700QZ-85	2200	28900
39	700QZ-85D	1900	18600
40	700QZ-100	2000	20700
41	700QZ-100D	1800	14000
42	700QZ-125	2200	19400
43	700QZ-125D	1600	12500
44	700QZ-160	1900	13400
45	700QZ-160D	1500	8800
46	700QZ-50C	3000	56500
47	700QZ-70C	2900	49900
48	700QZ-85C	2750	39900
49	700QZ-100C	2500	28700
50	700QZ-125C	2600	26700
51	700QZ-160C	2500	18600
52	800QZ-50	5500	64000
53	800QZ-70	4900	56800
54	800QZ-85	4200	45500
55	800QZ-100	4000	32400
56	800QZ-125	3800	30500
57	800QZ-160	3500	21100
58	900QZ-50	6000	72900
59	900QZ-70	5500	64400
60	900QZ-85	5500	51300
61	900QZ-100	5000	36900
62	900QZ-125	4000	34400
63	900QZ-160	3600	23900

QZ、QH系列泵重量表 QZ, QH series pump weight

序号 No.	型号 Type	最大泵重 The biggest pump heavy (kg)	最大轴向力 Max. axial force (N)
64	1000QZ-50	6800	91300
65	1000QZ-70	6500	80700
66	1000QZ-85	6000	64500
67	1000QZ-100	6000	46100
68	1000QZ-125	5500	43200
69	1000QZ-160	5000	29900
70	1200QZ-50	12000	117000
71	1200QZ-70	10100	101500
72	1200QZ-85	9800	72500
73	1200QZ-100	9500	58700
74	1200QZ-125	8800	51000
75	1200QZ-160	8000	37500
76	1400QZ-50	18000	155750
77	1400QZ-70	16300	135000
78	1400QZ-85	14000	96500
79	1400QZ-100	13200	78200
80	1400QZ-125	12700	67700
81	1600QZ-70	15000	187100
82	1600QZ-85	14000	130500
83	1600QZ-100	15800	106000
84	1600QZ-125	15000	91700
85	1600QZ-70C	18500	231700
86	1600QZ-85C	17900	165650
87	1600QZ-100C	17000	134200
88	1600QZ-125C	16500	116350
89	1800QZX-70	20000	260150
90	1800QZX-85	19000	185850
91	1800QZX-100	18000	150500
92	1800QZX-125	17000	130600
93	2000QZX-70	23000	350000
94	2000QZX-85	22000	250000
95	2000QZX-100	21000	201900
96	2000QZX-125	20000	175300

序号 No.	型号 Type	最大泵重 The biggest pump heavy (kg)	最大轴向力 Max. axial force (N)
97	2400QZX-85	25000	320000
98	2400QZX-100	23500	185150
99	2400QZX-125	22000	160650
100	350QH-40	500	9800
101	350QH-50	600	9700
102	400QH-40	1000	20000
103	400QH-50	800	13900
104	500QH-40	1700	31600
105	500QH-40D	1400	17800
106	500QH-50	1600	22000
107	500QH-50D	1400	12400
108	600QH-40	2000	45700
109	600QH-40D	1700	25700
110	600QH-50	1900	31800
111	600QH-50D	1500	17900
112	700QH-40	3900	57100
113	700QH-40D	2800	36800
114	700QH-50	3200	39700
115	700QH-50D	2600	25600
116	800QH-40	4300	80800
117	800QH-40D	3700	52100
118	800QH-50	4400	56200
119	800QH-50D	3500	36200
120	900QH-40	4800	96200
121	900QH-40D	4400	66300
122	900QH-50	4600	66900
123	900QH-50D	4200	46100
124	1000QH-40	7300	101000
125	1000QH-50	6500	88000
126	1000QH-35C	7800	113450
127	1000QH-50C	7300	82150
128	1200QH-40	12000	142450
129	1200QH-50	12600	103250
130	1400QH-50	13000	156200

QZ、QH系列泵各种附件附图 QZ、QH series pump various of attachments drawing

根据客户要求，我公司可供应下列附件：

1、拦污栅

视泵站规模，有自动出污及机械出污（去除拦栅上杂质）多种系列供用户选用，尺寸需现场确定。下图为拦栅除污机。

GS为钢丝绳式格栅除污机。

GSE为移动式格栅除污机。

We can support attachment follow attachments on customer's request.

1.Sewage Grid

Several kinds of series of automatic removing waste and mechanical removing waste(remove the impurity on the trashrack) will be supplied in accordance with the scale of pump station. The dimension should be decided on the spot. See the drawing of the grille waste removers below.

GS pattern steel cable grille waste remover.

GSE pattern movable grille waste remover.

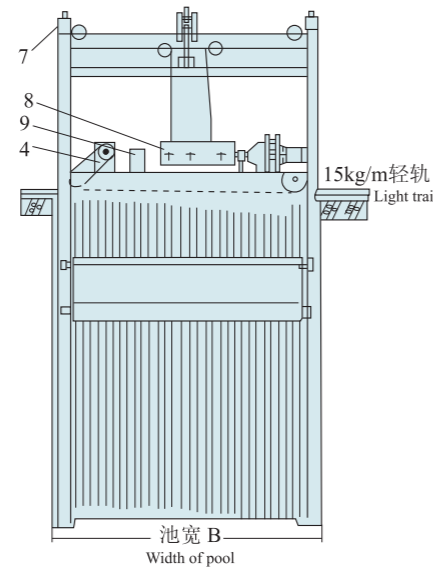
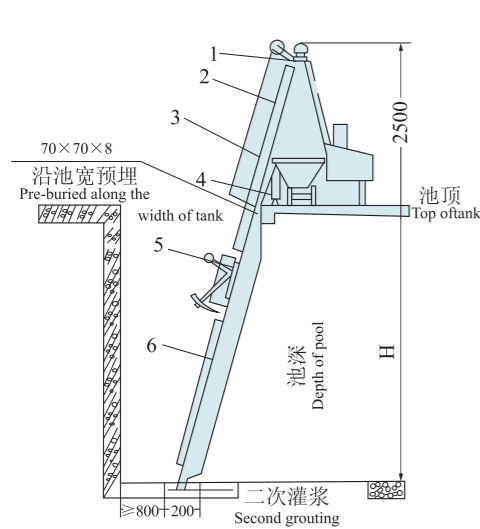

1	油压系统 Hydraulic press system
2	门形架 Gate frame
3	垃圾车 Rubbish vehicle
4	行车装置 Walking device
5	抓门 Grab bucket
6	栅条 Bar
7	保险装置 Insurance device
8	升降装置 Elevator
9	电气控制部分 Electric control part

主要规格及技术参数 MAIN SPECTTFICATION AND TECHNICALI PARAMETER

型号 Model	格栅宽度 Grid	井深(m) Well depth	栅条间距(mm) Space between bars	安装角度 Installing angle	电机功率 Motor power
GS GSE -1000	1000	2~12	20~100	60°~75°，特 殊情况时可用90° 60°~75°、90° for special condition	升降电机1.1~1.5kW，控制电机 0.75kW，行走电机0.8/0.4kW(双速) Elevting motor 1.1~1.5kW, Control moto0.75kW, Walking motor 0.8/0.4kW(Double-speed)
GS GSE -1250	1250				
GS GSE -1500	1500				
GS GSE -1750	1750				
GS GSE -2000	2000				

QZ、QH系列泵各种附件附图 QZ、QH series pump various of attachments drawing

2、拍门

A.浮箱式拍门外形及联接尺寸表

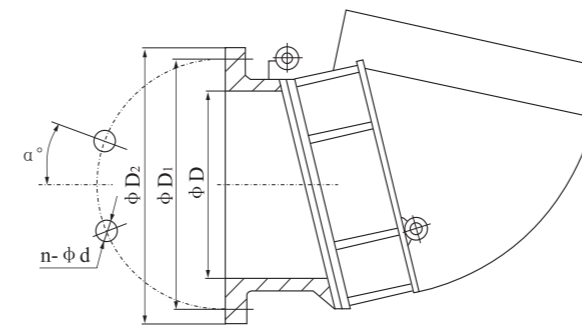

B.配重式拍门外形图及联接尺寸表

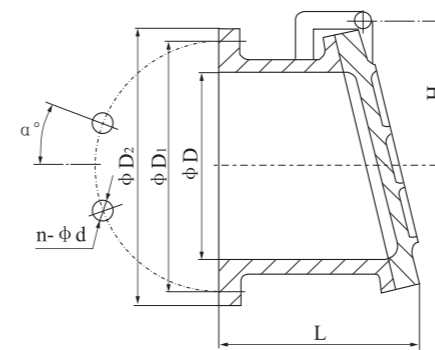

2.Flag valve

A. Appearance and connection dimension table for flap valve

井筒出水中径 Discharge caliber of well pipe	φD	φD ₁	φD ₂	n-φd	α°
400	400	495	540	8-23	22.5
500	500	655	710	6-27	30
600	600	705	755	10-27	18
700	700	810	860	12-27	15
800	800	920	980	12-27	15
900	900	1020	1075	12-27	15
1000	1000	1120	1175	12-27	15
1200	1220	1320	1380	12-27	15
1300	1300	1430	1500	10-27	18
1400	1400	1560	1630	12-36	15

B. Appearance and connection dimension for Alocated heavy flap valve

井筒出水中径 Discharge caliber of well pipe	φD	φD ₁	φD ₂	L	H	n-φd	α°
400	400	495	540	230	260	8-23	22.5
500	500	655	710	280	310	6-27	30
600	600	705	755	330	360	10-27	18
700	700	810	860	420	410	12-27	15
800	800	920	980	420	460	12-27	15
900	900	1020	1075	420	510	12-27	15
1000	1000	1120	1175	420	560	12-27	15
1200	1200	1320	1380	420	700	12-27	15
1400	1400	1560	1630	480	790	12-36	15

QZ、QH系列泵各种附件附图 QZ、QH series pump various of attachments drawing

3. 预埋管

3.Pre-buried pipe

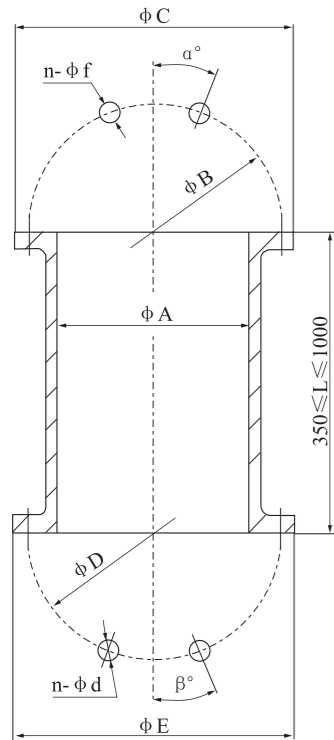

预埋管联接尺寸表 Connection Dimension Table For Pre-buried Pipe

穿墙管规格 Wall Pipe Specification	φA	φB	φC	n-φf	α°	φD	φE	n-φd	β°
400×L	400	495	540	16-22	11.25	495	540	8-23	22.5
500×L	500	600	645	20-22	9	655	710	6-27	30
600×L	600	705	755	20-26	9	705	755	10-27	18
700×L	700	810	860	24-26	7.5	810	860	12-27	15
800×L	800	920	975	24-30	7.5	920	980	12-27	15
900×L	900	1020	1075	24-30	7.5	1020	1075	12-27	15
1000×L	1000	1120	1175	28-30	6.429	1120	1175	12-27	15
1200×L	1200	1340	1405	32-33	5.625	1320	1380	12-27	15
1300×L	1300	1450	1520	32-36	5.625	1430	1500	10-27	18
1400×L	1400	1560	1630	36-36	5	1560	1630	12-36	15

注：L为预埋管长、由用户确定（350≤L≤1000）
Note: L is the length of pre-buried pipe and delided by customers(350≤L≤1000)

4. 液位开关

高性能Key液位开关，可实现按液位高低的变化自动控制泵的运行。

4. Water Level Switch

The key water level switch of high performance can control the operation of pump automatically according to fluctuation of water level.

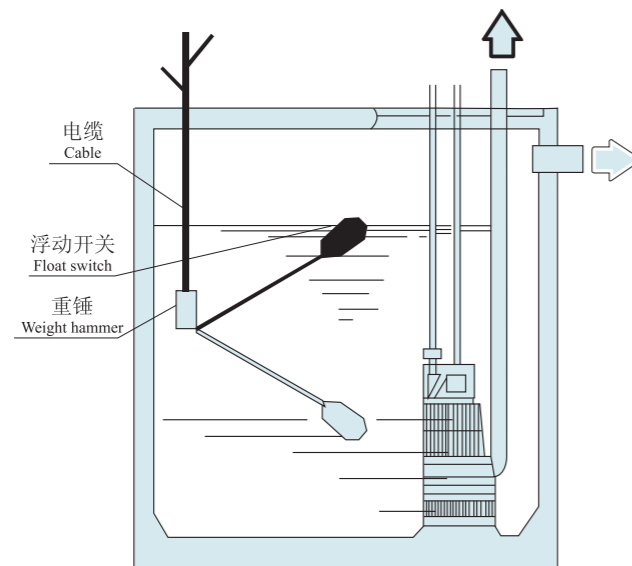

QZ、QH系列泵各种附件附图 QZ、QH series pump various of attachments drawing

5. 控制柜

- ①用途：专用控制柜可实行全自动保护，具有主回路短路、缺相、过载保护及泵门的无人看管，备泵自投及信号输出。具有单控型、手动切换一用一备型、定时自动切换一用一备型、交替自动切换一用一备型、手动切换二用一备型、手动切换三用一备型等多种控制方式，可满足用户的多种需要。
- ②适应范围：a. 环境温度-25℃~+40℃；b. 空气相对湿度不超过85%；c. 无爆炸危险的场合，且介质中无足以腐蚀金属和破坏绝缘的气体及导电尘埃。
- ③配套成套的中高压电控柜，实现泵站的电气动力自动控制。具体选用时参见连成样成。

5. Control panel

- ① Usage: Special control panel for QZ series axial flow pump has automatic protection system. It can check out mistakes like short circuit of main electric wires, lacking phrase, overload and can operate standby pump automatically and send out signal. All these can be done without human supervision. We have single control handle change type, handle change type with one running and one standby, automatic change fixed time with one running and one standby, alternatively automatic change type with one running and one standby, handle change type with two running and one standby, handle change type with three running and one standby, and so on. We can meet different requirements of customers.
- ② Application conditions: a. Ambient temperature from -25℃ to +40℃; b. Relative humidity below 85%; c. Operation place with no explosion risk, no metal erosion and isolation among gases, conductive dust.

6. 端子箱

设置端子箱的原意是便于安装施工操作。因此泵与电控柜之间的联接载体，现扩展为可带若干信号指示及部分控制功能的附加控制柜（仍称为端子箱），以解决中央控制室远离泵房时操作上的不便。在联接型和控制型基础上，又分为户内型和户外型共四种类型。

6. Terminal box

Using terminal box is for easy installation. The connection carrier between pump and control panel is expanded as an appendix control panel (still is a terminal box) which can carry signals and have some control functions. This can solve the problem of long distance between central control room and pump housing. Based on connection type and control type. We also have indoor type.

泵房布置简图 Pump station arrangement

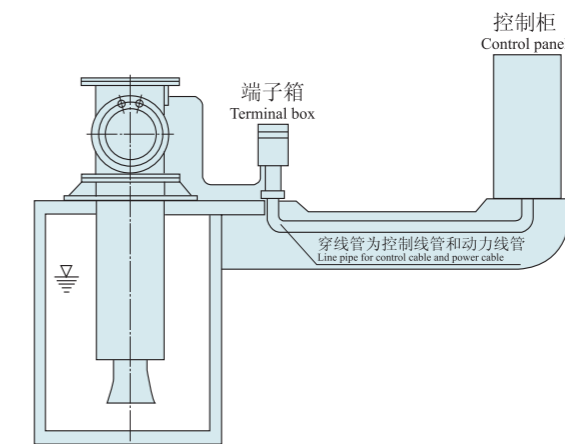

说明:

- 1.所有信号线可埋一根穿线管。
- 2.动力线按提供的电缆线直径、数量自行确定预埋管的大小。
- 3.动力线和信号线必须分别埋设管道，不可混穿。
- 4.端子箱与控制柜之间采用直流电流信号，可长距离输送，无衰减。
- 7.根据用户需求，我公司亦可供应闸阀、启闭机等其它附件。

订货须知 Instrument to order

- 1、订货时应注明准确的产品型号、产品名称、性能参数（流量、扬程、电机功率、使用电压），安装形式弯管（弯管悬吊式、井筒悬吊式、预制井筒式、开放式、闭式）。
- 2、控制柜应注明：起动方式（直接起动、自耦降压起动、可控硅软起动），控制数量（一控一、一控二、一控三、一控四等各种控制方式），液位控制方式（浮球液位、压力传感液位及其他方式），如配端子箱，应注明是控制型，还是接线型，是户外型，还是户内型。
- 3、本公司潜水电缆正常供货长度10m，若用户特殊要求，请予以注明。
- 4、若有其他特殊要求，签订合同前请与本公司生产技术部联系，签订合同时明确注明。
- 5、未注明特殊要求时电泵供电源的频率50Hz，电压一般为380V，功率大于315kW的，建议选用6kV、10kV。在合同中注明时接受50Hz，660V的订货要求。对其它频率（如60Hz）和电压的特殊产品可在订货时商洽。

Notes:

- 1.All signal cables allowed in a line pipe.
- 2.Power cable pipe diameter is decided by power cable diameter and num-ber.
- 3.Signal cables must be separated from power cables.
- 4.Signal transmitted between the cabinet and the terminal box are DC signals and is allowed to long distance trans-ference without attenuation.
- 7.We can also support sluice gate headstock gate etc. Attachments on customer's request.

- 1.Please give clear indication of correct product model, product description, characteristic (capacity, head, motor power, applicable voltage), installation mode(circular cantilever type, right-angle cantilever type, prefabricated type,open type, shut type).
- 2.The control cabinet should be given clear indication of start mode (direct start, decreasing voltage start, control silicon soft start), number of controlled pump (1 cabinet controls 1 pump, 1 cabinet controls 2 pumps, 1 cabinet controls 3 pumps, 1 cabinet controls 4 pumps, etc), elevation control mode (floating ball elevation, pressure sensor elevation and others). If you need terminal box ,please give clear indication of whether it is used for control or connecting cables and whether it is used for indoor or outdoor.
- 3.The length of submersible cable we should supply is 10 meters long, please give clear indication if you have special requirement.
- 4.If you have other particular requests, please contact with technical department of our company without hesitation before signing contract and give clear indication when signing contract.
- 5.When no special requirements are specified, the pump power supply source frequency of 50Hz, voltage is generally 380V, power is greater than 315kW, it is recommended to choose 6kV, 10kV. As stated in the contract, 50Hz and 660V order requirements are acceptable. Special products of other frequencies (e.g., 60Hz) and voltages can be negotiated at the time of order.

轴、混流潜水电泵及安装系统成套范围 Complete range of shaft, mixed current submersible pump and installation system

序号 No.	名称 Name	安装形式 Type of installation								备注 Remark
		井筒 悬吊式 Shaft suspension	井筒 落地式 Wellbore floor	弯管 悬吊式 Elbow suspension	水泥 井筒式 Cement shaft	斜拉式 Course	敞开式 I Open	敞开式 II Open	闸门 安装式 Gate mounting	
1	潜水轴、混流泵 Submersible shaft, mixed flow pump	★	★	★	★	★	★	★	★	订货时注明泵型、流量、扬程、电压、安装形式等 Specify pump type, flow rate, head, voltage, installation form, etc
2	座环 Seat ring	★	★	★	★			★	★	Q235A, HT200 或 or 304
3	钢制井筒 Steel shaft	★	★	★		★	★	★		Q235A 或 or 304
4	吸罩 Hood					★				
5	扩散管 Diffusion tube	☆	☆	☆	☆	☆	☆	☆	☆	
6	穿墙管 Wall tube	☆	☆	☆	☆	☆		☆	☆	
7	排水管 The drain					☆				
8	预埋井筒 Embedded wellbore				★					
9	异径弯管 Reducing pipe bending			★						
10	井盖 Manhole cover	★	★		★			★		
11	悬吊装置 Suspension device	★	★	★	★		★	★		
12	电缆夹紧装置 Cable clamping device	★	★	★	★	★	★	★	★	
13	雪橇组装 Sleigh assembly					★				
14	泵车组装 Pump truck assembly					★				
15	密封垫 Gasket	★	★	★	★	★	★	★	★	
16	标准紧固件 Standard fastener	★	★	★	★	★	★	★	★	普通钢制或不锈钢制 Ordinary steel or stainless steel
17	地脚螺栓 Anchor bolt	★	★	★	☆		★	★	☆	普通钢制或不锈钢制 Ordinary steel or stainless steel
18	拍门 Take the door	☆	☆	☆	☆	☆	☆	☆	☆	钢制重力式拍门或浮箱拍门 Steel gravity door or floating box door
19	可屈挠橡胶接头 Flexible rubber joint	☆	☆	☆	☆	☆	☆	☆	☆	
20	专用启动柜 Special starting cabinet	☆	☆	☆	☆	☆	☆	☆	☆	
21	接线端子箱 Terminal box	☆	☆	☆	☆	☆	☆	☆	☆	
22	综合保护器 Integrated protector	★	★	★	★	★	★	★	★	
23	动力电缆 Power cable	☆	☆	☆	☆	☆	☆	☆	☆	随机电缆长10米或订货时注明长度 Random cable length 10 meters or specify the length when ordering
24	控制电缆 Control cable	☆	☆	☆	☆	☆	☆	☆	☆	
25	水位控制器 Water level controller	☆	☆	☆	☆	☆	☆	☆	☆	
26	机械密封 Mechanical seal	☆	☆	☆	☆	☆	☆	☆	☆	
27	“O”型密封圈 “O” sealing ring	★	★	★	★	★	★	★	★	备品、备件 订货时注明数量 Indicate the quantity of spare parts when ordering
28	轴承 Bearing	☆	☆	☆	☆	☆	☆	☆	☆	
29	专用工具 Special tools	☆	☆	☆				☆	☆	

说明: ★为必购件, 是采用该种安装形式所必备的零部件; ☆为选购件, 由用户根据需要决定采购与否及数量。

Description: ★It is a must buy parts, is the necessary parts for the installation form; ☆for optional parts, the user shall decide whether to purchase or not and the quantity as required.

管路损耗参考表 Reference table for pipeline loss

流量 Capacity(L/s)																									
管径 Pipe diameter (mm)	1	2	4	6	8	10																			
25	32.7	13.0																							
38	3.5	14	55				15	20																	
50	0.8	3.1	13	29					25	30															
65		1.6	3.2	7.1	13	20					40	50													
75		0.4	0.8	3.3	5.9	9.6	21.6					60	70												
100			0.23	0.8	1.3	2.1	6.8	8.6	13	19.4			80	90											
125				0.23	0.4	0.63	1.3	2.7	4.1	5.9	10.7				100	110									
150					0.16	0.26	0.58	1.1	1.6	2.3	4.2	6.4	9.4			120	130								
175						0.11	0.27	0.5	0.74	1.05	1.9	2.9	4.3	5.8	7.7	9.6		140	160						
200							0.13	0.26	0.37	0.53	0.93	1.5	2.1	2.9	3.7	4.7	6.1	7.2	8.5	180	200				
250									0.07	0.12	0.18	0.30	0.48	0.68	0.93	1.2	1.5	1.9	2.3	3.3	4.9	5.2			
300											0.07	0.12	0.19	0.27	0.37	0.49	0.61	0.76	0.9	1.1	1.3	1.5	2.0	2.4	3.0

直管摩擦损失简表(估计用)100m直管损失米数以新铸铁管为标准,旧管加倍。
Brief table for the frictional loss of a straight pipe(for evaluation),the lost meters of a 100m straight pipe takes the newly iron pipe as the standard and multiple for the old one.

阀及弯管折合直管长度(每个)

The length of a straight pipe converted into from both valve and elbow(each)

种类 Variety	折合直管直径倍数 Convert into the times of the diameter of a straight pipe	备注 Remark
标准弯管 Standard elbow	12	未畅开加倍 Multiple in case of unopen
全开闸阀 Fully opened gate valve	25	
截止阀 Back valve	100	
底阀 Foot valve	100	部分堵塞加倍 Partial block-up multiplied

注: 例如100mm直径管, 底阀折合100倍直径等于100×100=10000mm=10m直径长度, 假定流量为8L/s查上表, 直管每100m损失1.3m, 则10m损失0.13m, 即一个100mm底阀, 流量为8L/s时, 损失扬程0.13m。

Note: For instance, a 100mm diameter pipe, the foot valve has a 100×100=10000mm=10m diameter when which is converted into 100 times that of the pipe's diameter. Suppose the flow is 8L/s. Looked into the above table, the loss of the straight pipe is 1.3m each 100m, then the one for 100mm is 0.13m, that is, for a 100mm foot valve with a flow 8L/s, its head loss is 0.13m.

一定管路直径之最大流量限制

Limit of the maximum flow for a pipe with a certain diameter

管径直径 Pipeline diameter (mm)	最大流量 Maximum flow (L/s)	最大流速 Maximum flow rate (m/s)	管径直径 Pipeline diameter (mm)	最大流量 Maximum flow (L/s)	最大流速 Maximum flow rate (m/s)
25	1	2.04	125	30.0	2.44
38	2.5	1.69	150	43.0	2.45
50	4.17	2.12	175	60.0	2.49
65	6.67	2.01	200	83.3	2.69
75	10.0	2.26	250	133.0	2.72
100	18.4	2.33	300	192.0	2.71

注: 超过此限使管路损失显著增加。
Note: The pipeline loss would be made greatly increased once the limit is over.